



**Yanmar SA Series
Cab with Heater (p/n: 1YANSAPR)
fits tractor models: SA 221, SA 324, SA 424, SA 325*,
SA 425*. Adaptor kit allows cab to fit with backhoe.**

While this cab kit was designed to fit on the vehicle(s) listed above, manufacturing tolerances and vehicle assembly may affect cab fitment. It is the responsibility of the cab installer to check all vehicle pedals and levers for full functionality and, as required, adjust the cab fitment to prevent any interference of the cab components with the travel of pedals or levers.



* Adaptor kit for Rear Dual SCV's (P/N: 1YANSARRAK) Required

Available Options:

1. Front LED Work Lights (P/N: 9LEDW4)
2. Rear LED Work Lights (P/N: 9LEDW3)
3. Strobe Light (P/N: 9LEDS2)
4. Dome Light (P/N: 9LEDD14)
5. Side View Mirrors (P/N: 9PM5)
6. Rear View Mirror (P/N: 9PM3)
7. Rear Wiper (P/N: 9PWK8512F9-11A)
8. Adaptor kit for Backhoe (P/N: 1YANSAPRBK). Contact Curtis for details.
9. Adaptor kit for Rear Dual SCV's (P/N: 1YANSARRAK)

Approximate Installation Time *
Experienced Dealer Technician – 4.5 Hours
Average Dealer Technician – 5.5 Hours
Do-It-Yourself – 6.5 Hours

(*Including the heater installation)

Approximate Product Specifications
Floorboard to Roof Height: 58.25 inches
Weight: 291 lbs.
Cab Width: 51.18 inches

The contents of this envelope are the property of the owner. Leave with the owner when installation is complete.

TABLE OF CONTENTS

WARNINGS, TIPS, & REQUIRED TOOLS.....	3
CAB INSTALLATION.....	4-21
CAB FEATURES & OPERATION.....	22
CARE AND MAINTENANCE.....	23
SERVICE PARTS	24-26
OPTIONAL ACCESSORIES	27
TORQUE CHARTS.....	28-29





WARNINGS, TIPS, & REQUIRED TOOLS

Curtis cabs feature an assembly of parts designed for your vehicle which require adjustment and alignment of components to accommodate vehicle variations and provide proper weather protection. For accurate installation, proper operation, and years of satisfaction, please read and understand the installation and owner's manual fully prior to installing the cab.

From all of us at Curtis, we thank you for choosing our product.

 NOTICE
<p>Curtis Cabs, blades and general accessories add additional weight to the base vehicle. All Curtis accessory weights are listed in product brochures. Deduct the accessory's total weight from the vehicle's rated capacity and never exceed the vehicle's rated capacity including driver and passenger.</p>

<p>WARNING Exposure to Carbon Monoxide can Cause illness, serious injury or death. Never operate vehicle if suspicious of Carbon Monoxide. Inspect exhaust system for leaks monthly. Leaks can result from loose connections, corrosion, cracks or other damage to the exhaust manifold. If leaks are found, repair or replace exhaust system. Do not use vehicle until repair or replacement is complete.</p>

 WARNING	
Serious Injury or Death	
	This cab enclosure does not provide protection from rollover or other accidents.
	This cab enclosure does not provide protection from flying objects including golf balls.
	This cab enclosure does not provide protection from lightning. When lightning threatens take cover and do not operate vehicle.

California Health and Safety Proposition 65 Warning: This product may contain chemicals known to the state of California to cause cancer and birth defects or other reproductive harm.

GENERAL INFORMATION BEFORE YOU START

HELPFUL HINTS:

- Refer to parts diagram found in the service parts section of this manual to help identify parts during the assembly process.
- To assist with the cab installation, leave all fasteners loose for later adjustment unless otherwise specified.
- Read and understand all instructions before beginning.
- Apply a silicone sealant to seal any minor gaps that may occur due to vehicle variations.
- Use caution to avoid damaging the factory installed threaded inserts or weld nuts. Begin the thread engagement by hand to avoid or correct potential cross threading.
- Make sure the areas where the supplied self-adhesive hook Velcro and seals will be applied are clean, dry, and at room temperature for best adhesion.
- Before installing parts with factory installed rubber, make sure the rubber is fully installed onto the parts for proper fit and sealing.
- Plastic washers have been supplied to provide a weather seal under the heads of some exterior bolts. The plastic washer should be installed under each bolt head directly against the outside cab surface. Care should be taken not to over tighten the fasteners and damage the plastic washer.

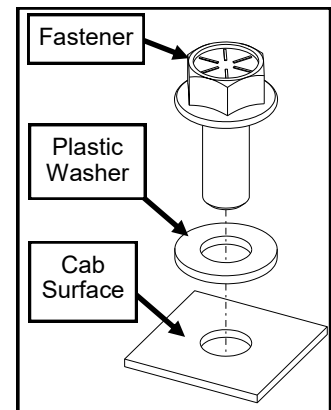

TOOLS REQUIRED:

- Set of Standard and Metric Sockets including deep sockets (3/8" Drive)
- 3/8" Drive Ratchet with extension
- Torque Wrench
- Set of Standard and Metric Open-End Wrenches
- Set of Standard and Metric Allen Wrenches
- #2 and #3 Phillips Head Screwdrivers
- Drill/Driver
- #2 and #3 Phillips Head Bit
- Utility Knife
- Pair of Scissors
- Shears
- Grease
- Silicone Sealant
- Teflon Tape
- Tape Measure

CAB INSTALLATION

STEP 1: (VEHICLE PREP)

- 1.1 Disconnect the negative battery cable.
- 1.2 If equipped, remove and set aside the SMV sign.
- 1.3 Remove and discard the left rear fir tree clip holding down the floor mat. See Figure 1.3.
- 1.4 Remove and save all the fir tree clips from the right floor mat and temporarily remove the mat. Punch a 5/8" hole in the center of the underside-indent in the mat in the location shown. See Figure 1.4.
- 1.5 Remove and discard the M8 bolt in location shown in Figure 1.4.
- 1.6 Re-install the right side floor mat using the fir tree clips removed earlier.
- 1.7 Install the supplied aluminum spacer in the hole in the right side floor mat. See Figure 1.7.
- 1.8 Loosen the nuts on the rear flashers and slide them out of the brackets. Keeping the wires attached, let the flashers rest on the rear fenders out of the way. See Figure 1.8.
- 1.9 If installed, remove left side step and save all hardware for re-installation later. See Figure 1.9.
- 1.10 If a rear SCV is installed, disconnect the hoses from the SCV and remove from the ROPS. Refer to the SCV installation instructions for installation after the cab is complete.

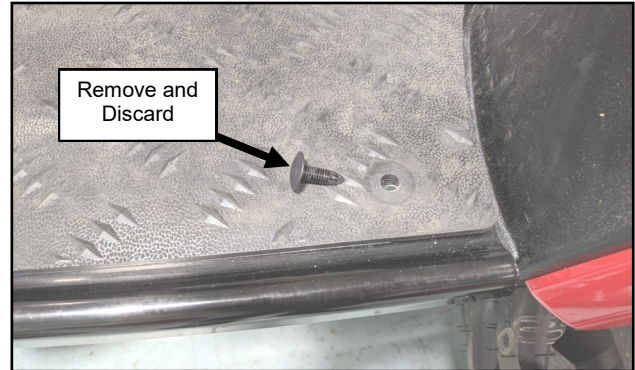

Fig. 1.3 (Remove Left Rear Fir Tree Clip)

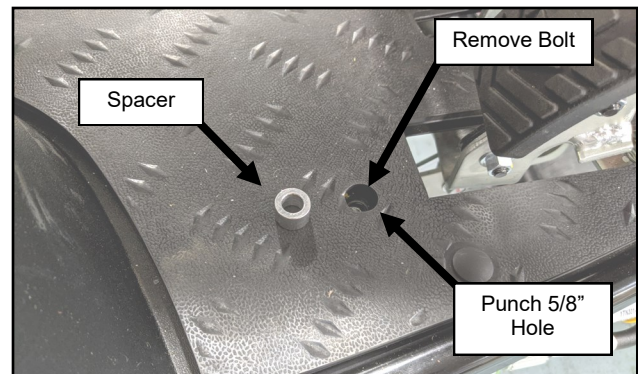

Fig. 1.4 (Punch Hole in Right Floor Mat)

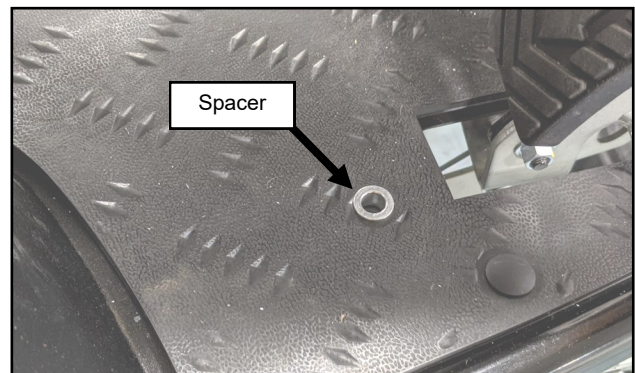

Fig. 1.7 (Install Spacer)

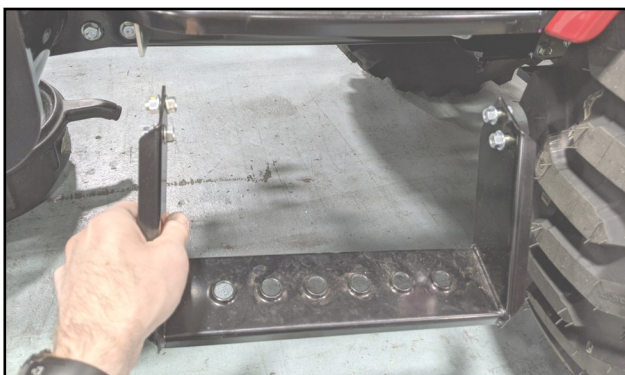

Fig. 1.9 (Remove And Save Step)

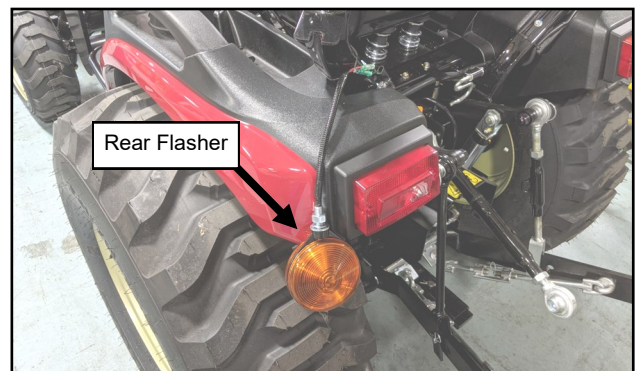

Fig. 1.8 (Move Rear Flashers)

CAB INSTALLATION

STEP 2: (PRE-ASSEMBLE REAR LEG)

- 2.1 Pre-assemble the left rear leg and a ROPS mount. See Figure 2.1.

<u>Hardware Used</u>	<u>Qty</u>
5/16-18 X 3/4 Hex Head Screw	2
5/16-18 Hex Nut	2

Tools required
1/2" wrench and socket

- 2.2 Repeat step 2.1 for right rear leg.

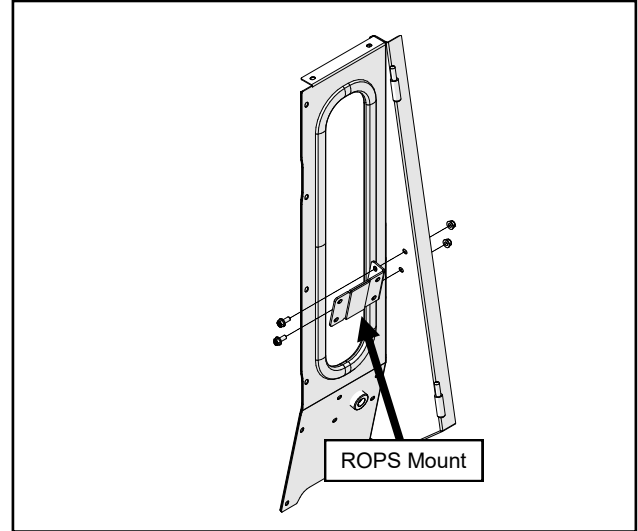

Fig. 2.1 (Pre-Assemble ROPS Mount to Rear Leg)

STEP 3: (REAR LEG AND ROPS MOUNTS)

- 3.1 Slide on the lower ROPS clamp (taller one) onto the ROPS just above the flasher bracket. See Figure 3.1.
- 3.2 With help, attach the left rear leg assembly to the lower ROPS clamp as well as adding an upper ROPS clamp. Leave hardware loose at this time. See Figure 3.2. Ensure there is a gap between the rear leg and the fender.

<u>Hardware Used</u>	<u>Qty</u>
5/16-18 X 3/4 Hex Head Screw	8
5/16-18 Hex Nut	8

Tools required
1/2" wrench and socket

- 3.3 Repeat steps 3.1 and 3.2 for right rear leg.

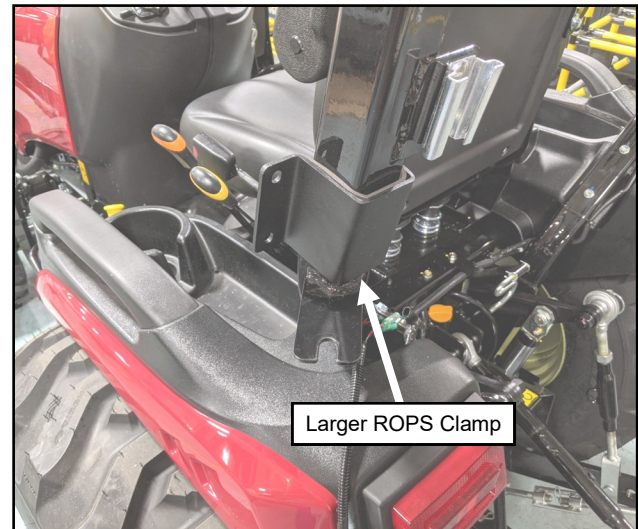

Fig. 3.1 (Slide On Lower ROPS Bracket)

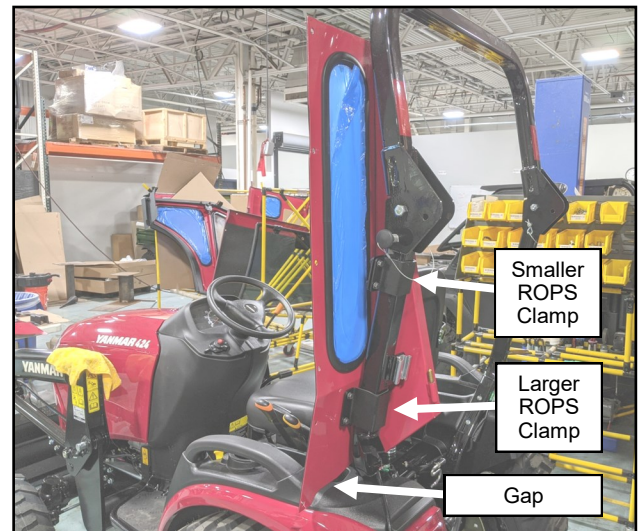

Fig. 3.2 (Install Left Rear Leg)

CAB INSTALLATION

STEP 4: (SIDE FRAMES)

- 4.1 With assistance, remove the left door from the left side frame by unlatching at the middle handle and lifting the door off the hinges. Remove the 2 brass washers from the side frame and set aside for later use. Position the left side frame in place and loosely secure to the left rear leg. See Figure 4.1.

<u>Hardware Used</u>	<u>Qty</u>
5/16-18 X 3/4 Hex Head Screw	6

Tools required
1/2" wrench or socket

- 4.2 Secure the left side frame to the floor pan through the hole from the fir tree plug removed earlier. See Figure 4.2.

<u>Hardware Used</u>	<u>Qty</u>
1/4-20 X 3/4 Button Head Screw	1
1/4-20 Hex Nut	1

Tools required
5/32" Allen Wrench
7/16" wrench or socket

- 4.3 Repeat step 4.1 for the right side frame.

<u>Hardware Used</u>	<u>Qty</u>
5/16-18 X 3/4 Hex Head Screw	6

Tools required
1/2" wrench or socket

- 4.4 Secure the right side frame to the floor pan through the floor mat hole punched earlier and the aluminum spacer. See Figure 4.4.

<u>Hardware Used</u>	<u>Qty</u>
M8x1.25 X 35mm Button Head Screw	1

Tools required
5mm Allen Wrench

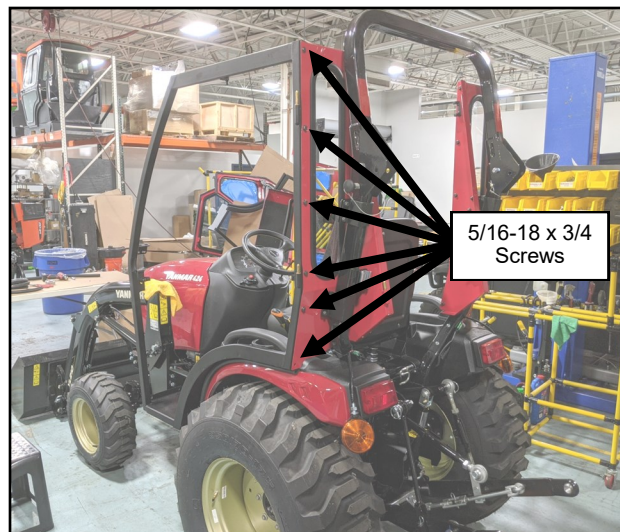

Fig. 4.1 (Install Left Side Frame)



Fig. 4.2 (Install Left Side Frame)

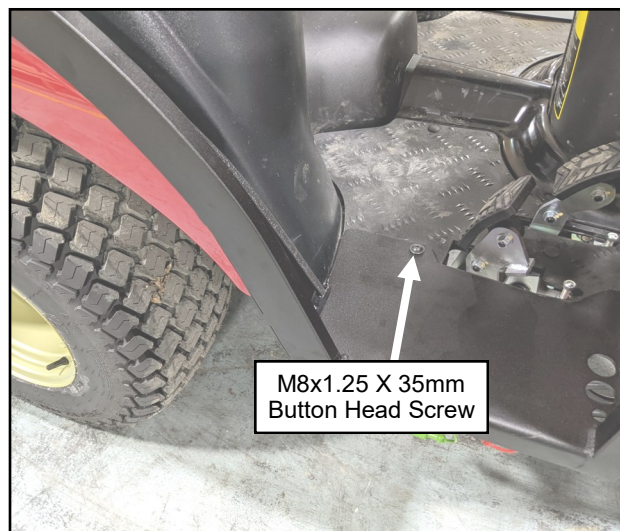

Fig. 4.4 (Install Right Side Frame)

CAB INSTALLATION

STEP 5: (REAR FLASHERS)

- 5.1 Attach a flasher relocation bracket to the flasher mounting tab on the ROPS. See Figure 5.1.

<u>Hardware Used</u>	<u>Qty</u>
1/2-13 X 1 Hex Head Screw	1
1/2-13 Hex Nut	1

Tools required
3/4" wrench or socket

- 5.2 Slide the flasher into the slot in the flasher relocation bracket and tighten the nut. See Figure 5.1.
- 5.3 Repeat steps 5.1 and 5.2 for the right rear flasher.



Fig. 5.1 (Install Rear Flashers)

STEP 6: (WINDSHIELD SUPPORT)

- 6.1 With assistance, hold the windshield support in place and attach with a screw to the front of each side frame. See Figure 6.1. Do not screw in the top at this point.

<u>Hardware Used</u>	<u>Qty</u>
5/16-18 X 3/4 Hex Head Screw	2

Tools required
1/2" wrench or socket

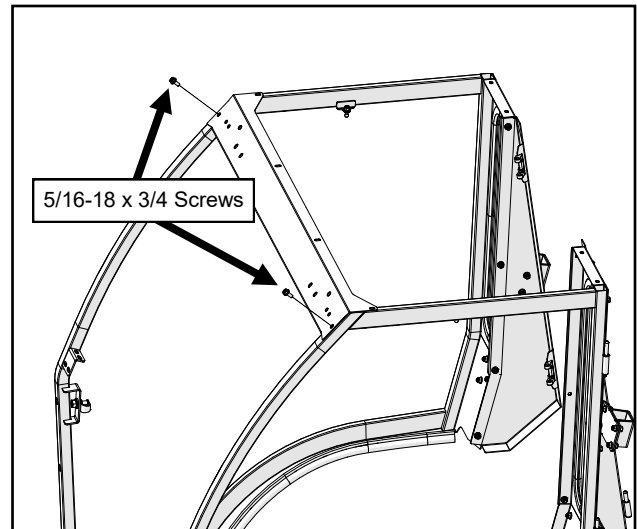

Fig. 6.1 (Install Windshield Support)

STEP 7: (COWL)

- 7.1 With assistance, carefully slide the cowl in place and loosely secure with fasteners. See Figure 7.1.

<u>Hardware Used</u>	<u>Qty</u>
5/16-18 X 3/4 Hex Head Screw	14
5/16-18 Hex Nut	8

Tools required
1/2" wrench and socket

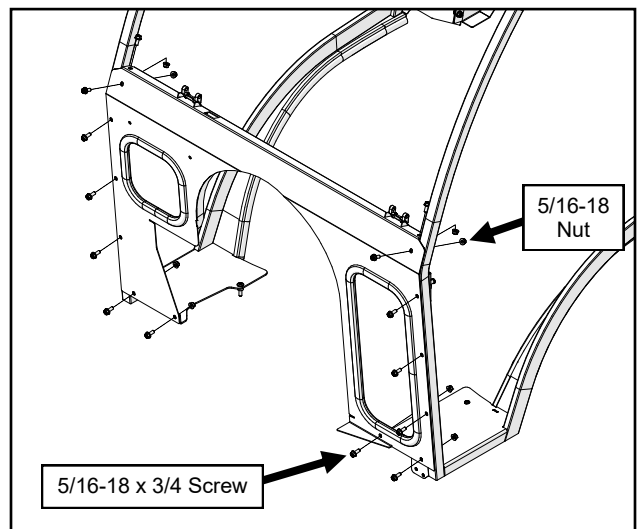

Fig. 7.1 (Install Cowl)

CAB INSTALLATION

STEP 8: (WINDSHIELD)

- 8.1 Check the windshield support for squareness to the side frames and tighten the two screws to 12.5 ft.-lbs.
- 8.2 With assistance, set the windshield up to the side frames and secure it to the windshield support using the hinge spacers and hardware. See Figure 8.2. Leave hardware loose.

Hardware Used

	Qty
5/16-18 x 1.5" Flat Head Screw	4
5/16-18 Hex Nut	4

Tools required

#3 Phillips screw driver
1/2" wrench or socket.

- 8.3 Close the windshield while lifting up on the bottom edge. Tighten hinge hardware. **Caution: The windshield hinges are plastic components. Do not overtighten the flat head screws. Torque to 7 ft.-lbs. max.**

Tools required

Torque Wrench

- 8.4 Ensure the windshield latches function properly and the windshield pivots open.
- 8.5 Remove the over-tightening caution decal from the top of the windshield.

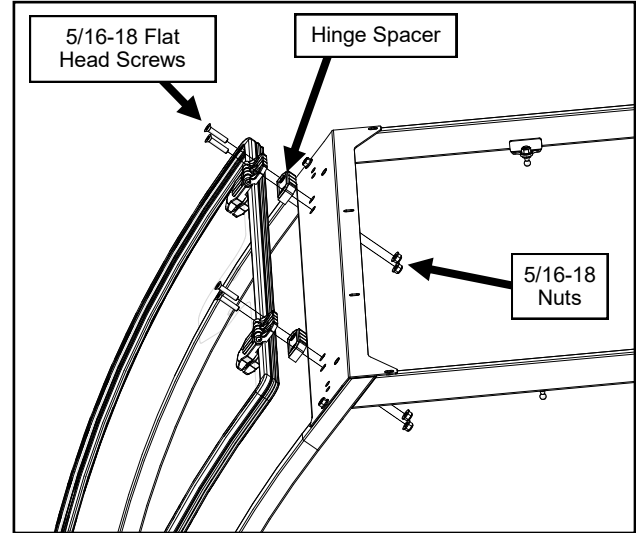

Fig. 8.2 (Attach Windshield)

STEP 9: (WINDSHIELD WIPER MOTOR)

- 9.1 Mount the wiper motor to the windshield. See Figure 9.1.

NOTE: Do not install the wiper arm and blade at this time. Once all the wiring is complete and power is restored, it can be turned on and off to ensure that the wiper arm will be parked in the correct position once it is attached at a later step.

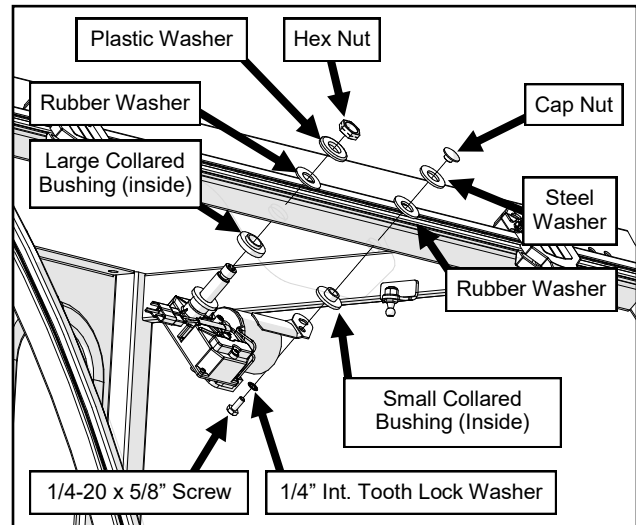

Fig. 9.1 (Windshield Wiper Motor)

STEP 10: (ROOF)

NOTE: If installing a Backhoe Compatibility Kit, refer to the Backhoe Compatibility Kit Installation Instructions for the roof installation and then proceed to step 11 of these installation instructions.

- 10.1 With assistance, set the roof on top of the cab. Loosely secure with sealing washers on the (8) screws through the top of the roof. See Figure 10.1.

Hardware Used

	Qty
5/16-18 x 3/4" Hex Head Screw	8
5/16" Sealing Washer	8
5/16-18 Hex Nut	4

Tools required

1/2" Wrenches and/or Sockets

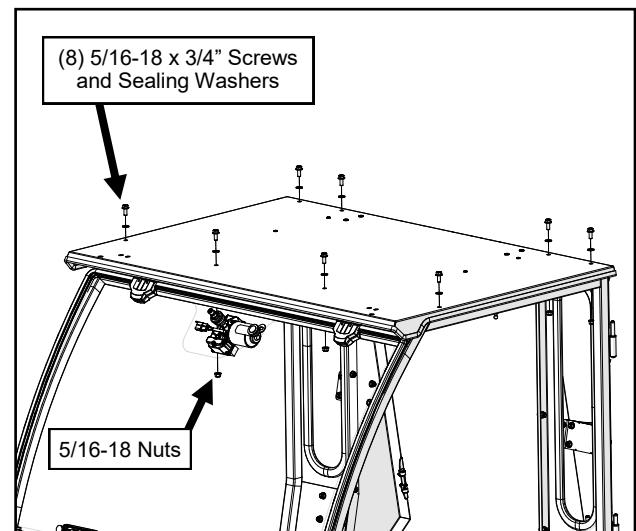

Fig. 10.1 (Install Roof)

CAB INSTALLATION

STEP 11: (REAR WINDOW)

- 11.1 Measure the back of the rear legs, inside to inside, and adjust the width to 24-7/8". Measure corner to corner for squareness, and **tighten the (8) sets** of screws and nuts that attach the rear legs to the ROPS, to lock in this width. See figure 11.1
- 11.2 Grease the hinge pins for the rear window, and slide on greased brass washers (one washer per pin). See Figure 11.2.
- 11.3 Hang the rear window on the hinges.
- 11.4 Connect the window latches to the right rear leg by depressing the tabs on the latch and inserting into the receivers mounted on the rear leg. Close and check the alignment of the window. If off, check measurements and re-align the rear legs. Tighten the hinge hardware to 7 ft.-lbs. Verify smooth operation of the latches.

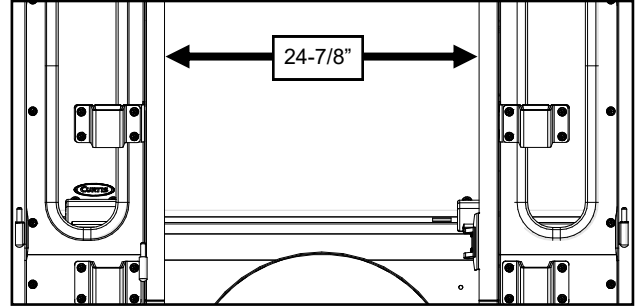

Fig. 11.1 (Measure Rear Legs Left to Right)

STEP 12: (TIGHTEN HARDWARE)

- 12.1 Tighten all hardware at this time, using the torque values given below.

Each side frame can be pushed inward at the back to close any gaps along the fender contour before tightening hardware.

For 5/16" bolts that thread into factory installed threaded inserts in the side frames without plastic washers, use 20 ft.-lbs.

For 5/16" bolts that use plastic washers, use only 12.5 ft.-lbs.

For the remaining 5/16" bolts (the vast majority on the cab) that thread into hex nuts, use 28 ft.-lbs.

For all other bolt sizes, reference the torque tables at the end of the manual.

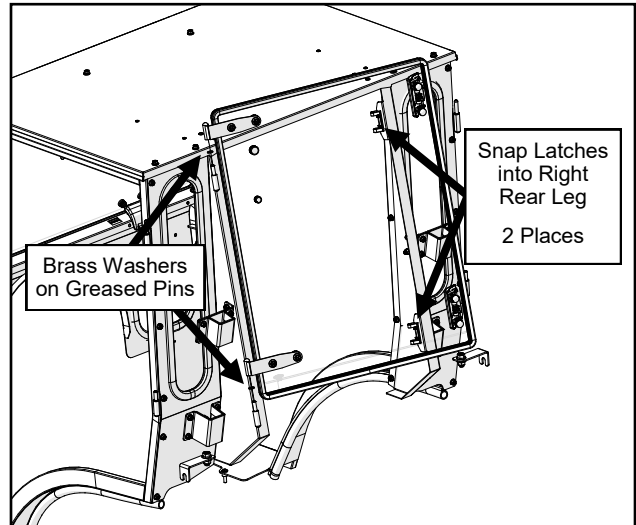

Fig. 11.2 (Hang Rear Window)

STEP 13: (LEFT STEP)

- 13.1 If equipped, re-install the left step to the new relocation tabs on the side frame using the hardware saved earlier. See Figure 13.1

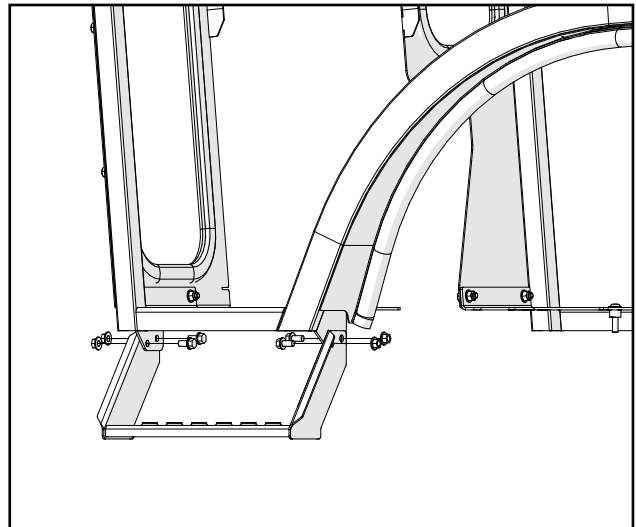

Fig. 13.1 (Install Left Step)

CAB INSTALLATION

STEP 14: (FRONT FILLERS)

- 14.1** Pre-install the supplied Velcro to both front fillers. Leave the release tape on until the filler is in place.
- 14.2** Set the left/center filler in place over the center console. See Figure 14.2. The front of the filler should rest on the arch on the cowl and run tight to the front face. Do not apply the Velcro at this time. Note the channel in the console that the filler needs to follow to seal properly.
- 14.3** The left side of the filler runs along the left window, then transitions from inside to outside the cab through the slot. See Figures 14.3a and b. Do not apply the Velcro at this time. The inner bottom of the filler should sit just on top of the vehicle floor pan.

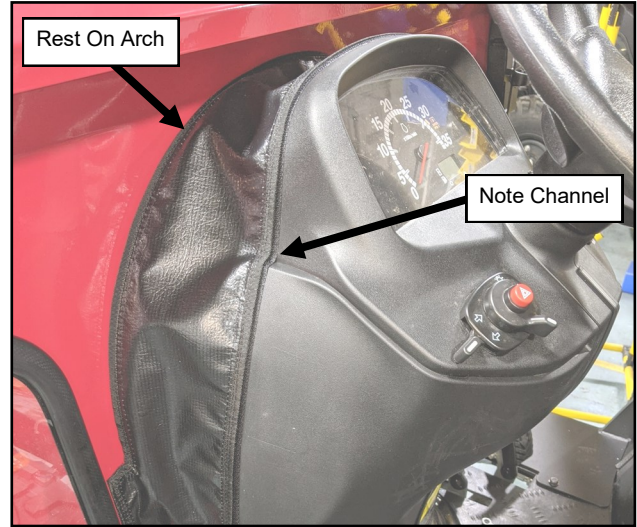

Fig. 14.2 (Set Left/Center Filler Into Place)



Fig. 14.3a (Left Side Of Filler)

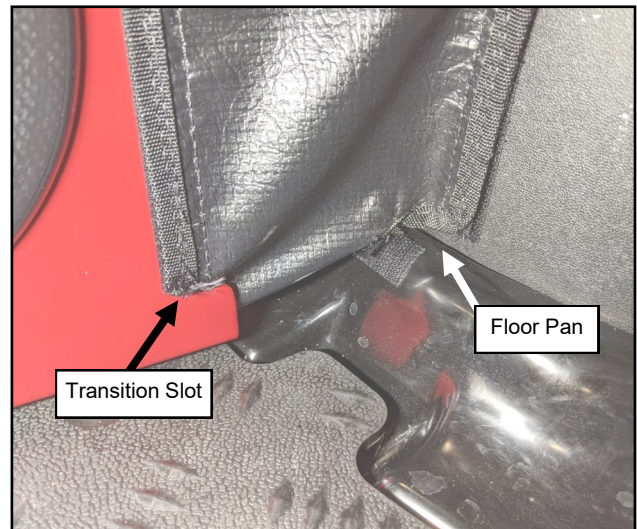

Fig. 14.3b (Inside View Of Left Side Transition)

CAB INSTALLATION

STEP 14: (FRONT FILLERS CONT'D)

- 14.4** With the left side located, the right side should end in-line with the cutout in the cowl. See Figure 14.4. Start securing the filler in place with Velcro while ensuring the filler stays in place. Force the filler to follow in and out of the channel on both sides of the console noted in Figure 14.2 on the previous page.
- 14.5** Secure outside of the left side of the filler to the cowl and floor pan. See Figure 14.5. Ensure there are no gaps between the filler, the cowl, and the floor pan.
- 14.6** Slide the Right Side Filler over the brake pedal through the pedal slit in the bottom and set into place. See Figure 14.6. Do not secure Velcro at this time.
- 14.7** Slide the top right edge of the filler through the transition slot. See Figure 14.6. Secure the top of the filler to the left/center filler and cowl, then secure sides, followed by the bottom along the floor pan.

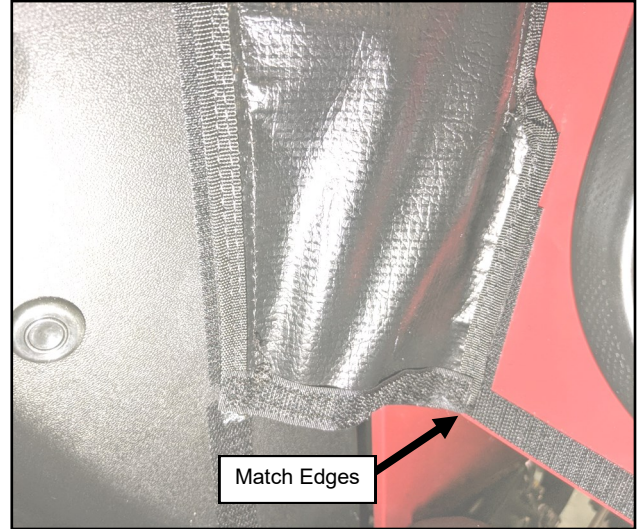

Fig. 14.4 (Secure Right Side Of Filler)

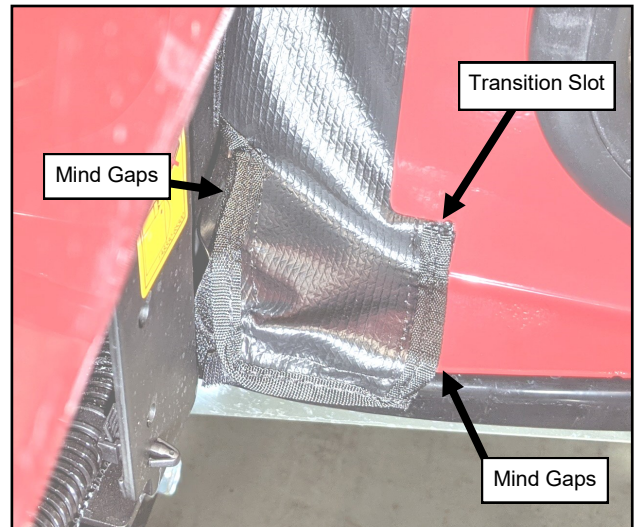

Fig. 14.5 (Outside View Of Left Side Transition)

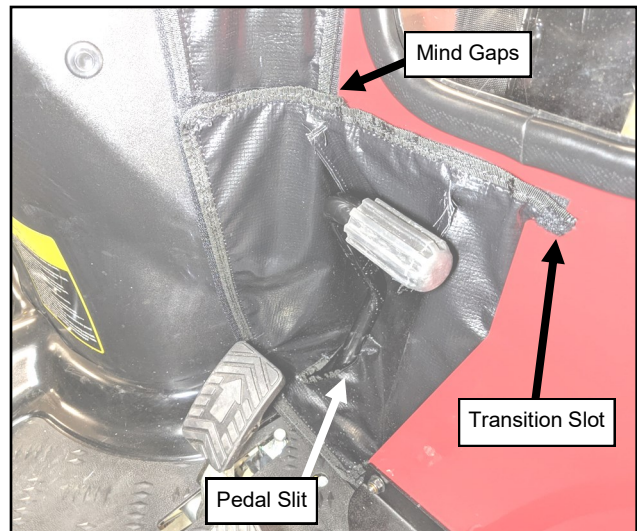

Fig. 14.6 (Right Side Filler)

CAB INSTALLATION

STEP 15: (CAB WIRING)

- 15.1 Attach the main power wire harness to the windshield wiper connector, and secure to the windshield support using a P-clip and hardware. Make sure there is enough slack to fully open the windshield. See Figure 15.1.

Hardware Used

	Qty
#10-32 x 1/2" Pan Head Screw	1
#10-32 Hex Nut	1

Tools required

#2 Phillips Screw Driver
3/8" Wrench or Socket.

- 15.2 Run the harness along the windshield support and down the side frame. Secure it with (2) more P-clips and hardware. See Figure 15.2. Connect the harness to the heater switch.

Hardware Used

	Qty
#10 x 3/4" Self-Drill Screw	2

Tools required

#2 Phillips Screw Driver

- 15.3 Snap in the heater switch into the rectangular cutout in the cowl and connect the harness. See Figure 15.3. Secure harness to side frame just above the cowl using a P-clip and self-drill screw. Use a cable tie to loosely secure the harness wires together as shown.

Hardware Used

	Qty
#10 x 3/4" Self-Drill Screw	1

Tools required

#2 Phillips Screw Driver

- 15.4 Secure the harness with one more P-clip halfway between the two P-clips on the side frame.

Hardware Used

	Qty
#10 x 3/4" Self-Drill Screw	1

Tools required

#2 Phillips Screw Driver

- 15.5 The rest of the harness runs down the side frame and through the 1/2" hole in the floorboard. See Figure 15.5. The harness will be secured at a later step along with the heater hoses.

The rest of the connections will be finished after the heater installation.

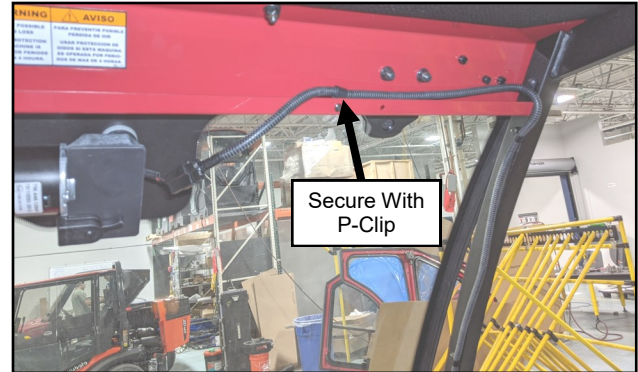

Fig. 15.1 (Attach Main Harness To Wiper Connector)

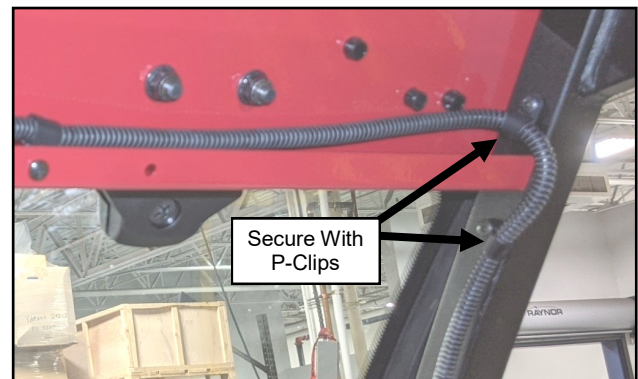

Fig. 15.2 (Secure Harness With P-Clips)

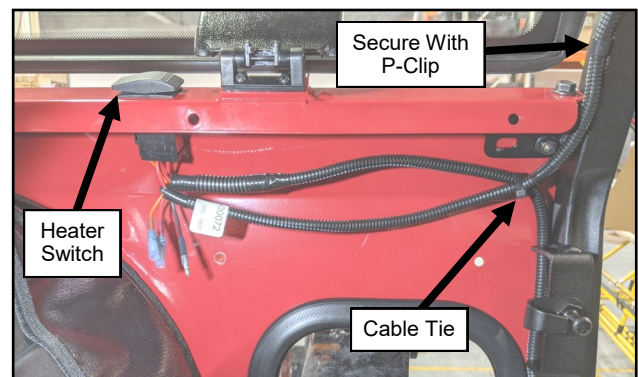

Fig. 15.3 (Route Harness To Heater Switch)



Fig. 15.5 (Harness Runs Down Side Frame)

CAB INSTALLATION

STEP 16: (PRE-ASSEMBLE HEATER)

16.1 Remove the heater screws shown in Figure 16.1 and reuse to attach the heater brackets to the sides of the heater box. Tighten hardware.

Tools required

#2 Phillips Screw driver

16.2 Apply 1/4" wiring loom to the heater wires. See Figure 16.2.

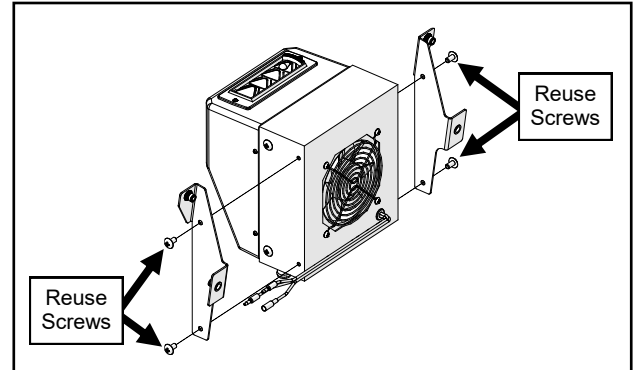

Fig. 16.1 (Pre-Install Heater Brackets)

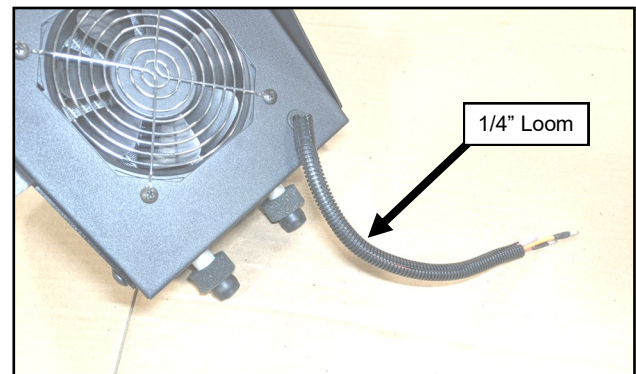

Fig. 16.2 (Apply Loom to Heater Wires)

STEP 17: (INSTALL HEATER)

17.1 Install the 2 supplied plastic snap bushings in the right cab floorboard. See Figure 17.1.

17.2 Attach the heater to the cowl. See Figure 17.2.

Hardware Used

1/4-20 x 5/8" Hex Head Screw

Qty

4

Tools required

3/8" socket or wrench

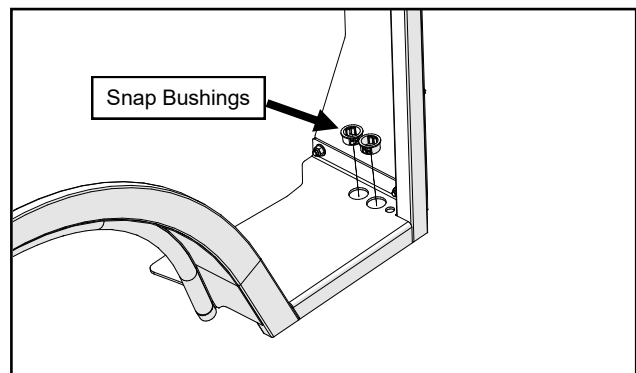

Fig. 17.1 (Install Snap Bushings)

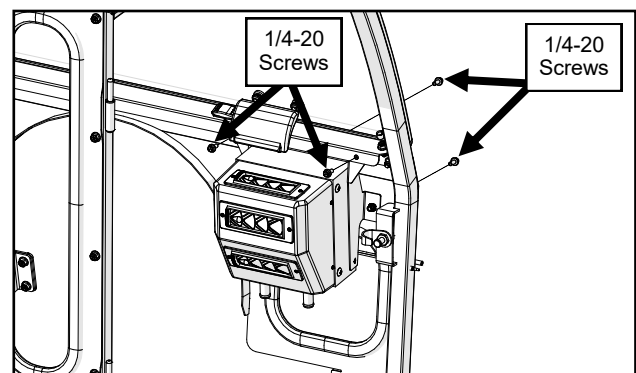

Fig. 17.2 (Install Heater)

CAB INSTALLATION

STEP 17: (INSTALL HEATER CONT'D)

- 17.3 Connect the heater leads to the wiring harness. See Figure 17.3.
- 17.4 Apply the supplied 1/2" wire loom to the heater wires. See Figure 17.4.

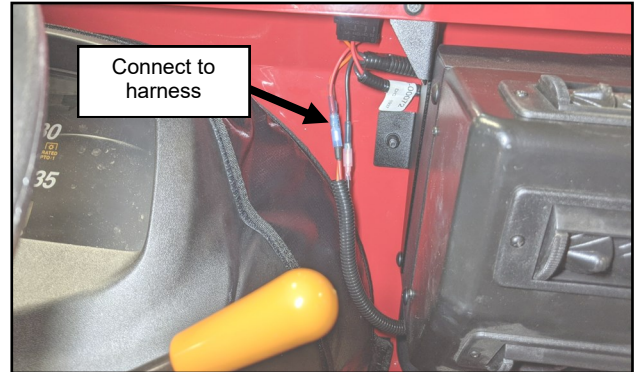

Fig. 17.3 (Connect Heater Leads to Wiring Harness)

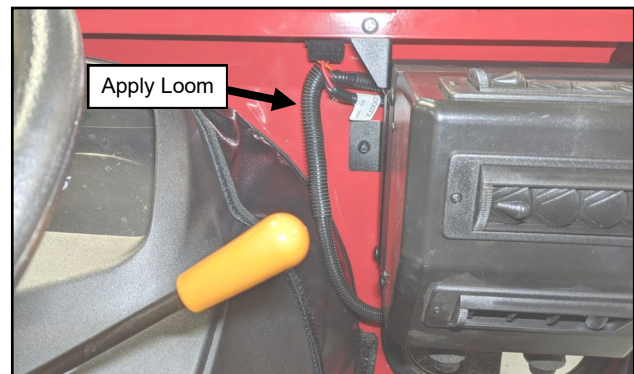

Fig. 17.4 (Apply 1/2" Wire Loom)

STEP 18: (HEATER PLUMBING)

- 18.1 Drain coolant (There is a drain hose connected to the radiator on the right side).
- 18.2 Confirm the coolant has completely drained from the other side and reconnect the drain hose. Relocate your drain pan under the lower radiator hose, loosen the clamp, and remove the hose from the radiator.
- 18.3 Cut the lower radiator hose 1.5" above the lower bend. Then cut an additional inch off of the end still attached to the engine to make room for the heater tee. See Figure 18.3.
- 18.4 Install the supplied tee fitting and one of the large hose clamps to the bent piece of radiator hose leaving the clamp loose for now. Install the assembly back onto the radiator with the original clamp. See Figure 18.3.
- 18.5 Attach the lower radiator hose to the other side of the tee fitting with the remaining large hose clamp. Inspect the lower radiator hose to confirm it is not pushed up against any sharp edges and further trim to length if necessary. Orient the Tee fitting per figure 18.3 and tighten the clamps.

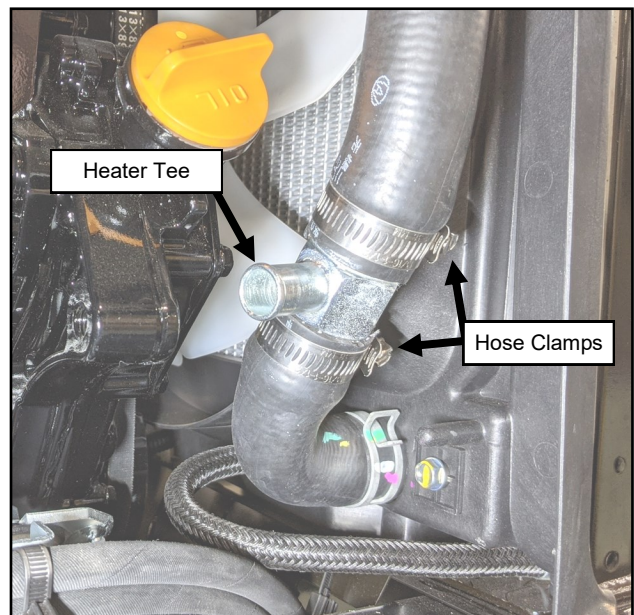

Fig. 18.3 (Tee Fitting)

CAB INSTALLATION

STEP 18: (HEATER PLUMBING CONT'D)

- 18.6** Unplug and remove the temperature sending unit from the thermostat housing.
- 18.7** Thread in the sending unit adapter using Teflon tape. Ensure the threaded hole in the middle faces up. See Figure 18.7.
- 18.8** Thread the 90° elbow into the middle threaded hole using Teflon tape. See Figure 18.7.
- 18.9** Thread the hose nipple into the 90° elbow using Teflon tape. See Figure 18.7.
- 18.10** Thread the temperature sending unit into the end of the sending unit adapter using Teflon tape. See Figure 18.7. Re-connect the sending unit wiring.
- 18.11** From inside the cab, insert each end of the supplied heater hose through each bushing in the floorboard and route them inward toward the brake pedal and up toward the engine. Use the natural curve of the hose to take corners and prevent kinking.
- 18.12** Connect one end of the hose to the hose nipple with a small hose clamp. See Figure 18.12.
- 18.13** Connect the other end of the hose to the tee fitting with a small hose clamp. See Figure 18.13.

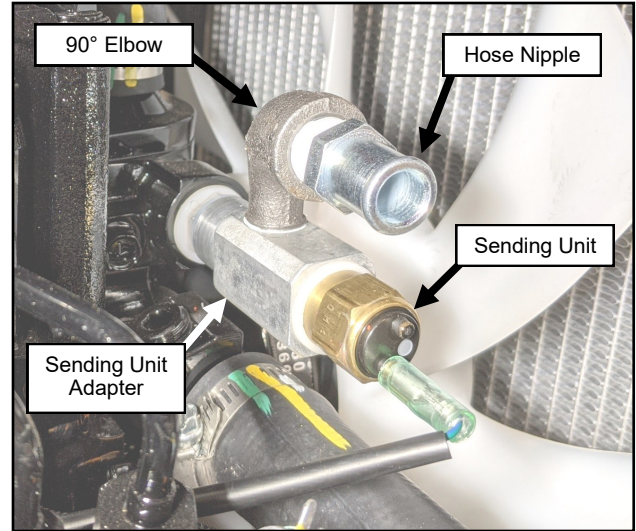

Fig. 18.7 (Heater Sending Unit Adapter Assembly)

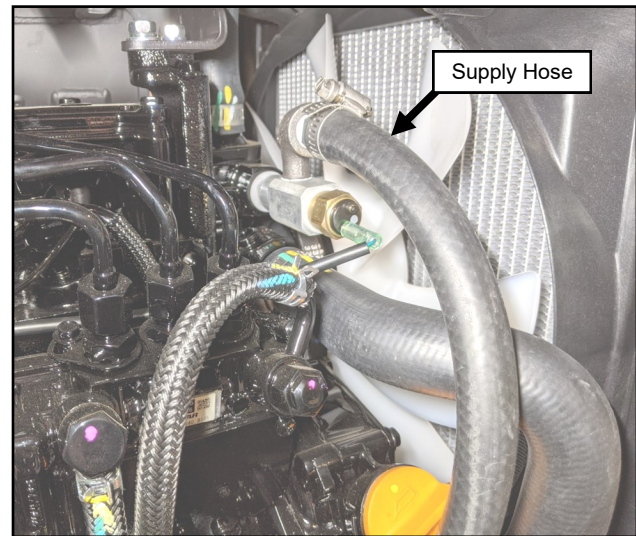

Fig. 18.12 (Heater Supply Hose)

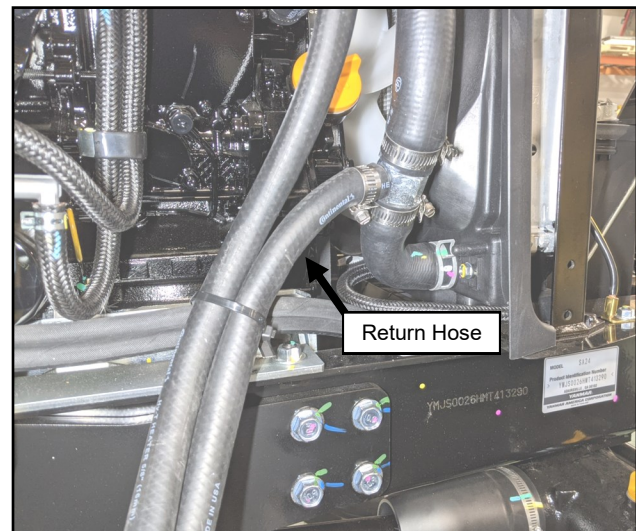

Fig. 18.13 (Heater Return Hose to Tee)

CAB INSTALLATION

STEP 18: (HEATER PLUMBING CONT'D)

- 18.14** At installer's preference, select a location to splice the supplied shut-off valve into the supply line coming from the nipple in the sending unit adapter. See Figure 18.14.
- 18.15** Wrap the hose closest to the vehicle under the floor pan with the supplied spiral wrap to protect heater hose. See Figure 18.15.
- 18.16** Inside the cab, cut the hose to length and connect to the heater with small hose clamps. See Figure 18.16.
- 18.17** Use the supplied large P-clip and a self-drill screw to secure the heater hose and wiring harness to the side frame. See Figure 18.16. Ensure the hose does not interfere with brake pedal use.

Tools required

#2 Phillips Screw driver

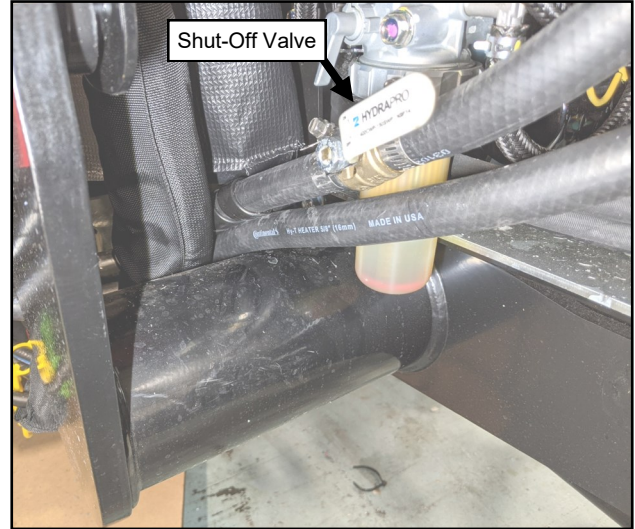

Fig. 18.14 (Heater Shut-Off Valve)

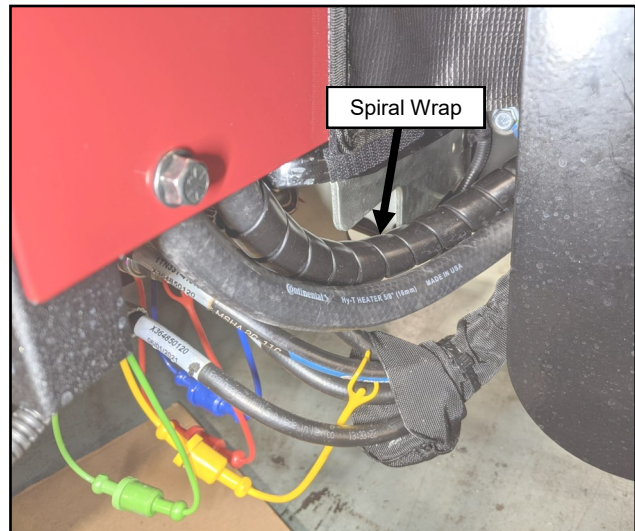

Fig. 18.15 (Heater Supply Hose)

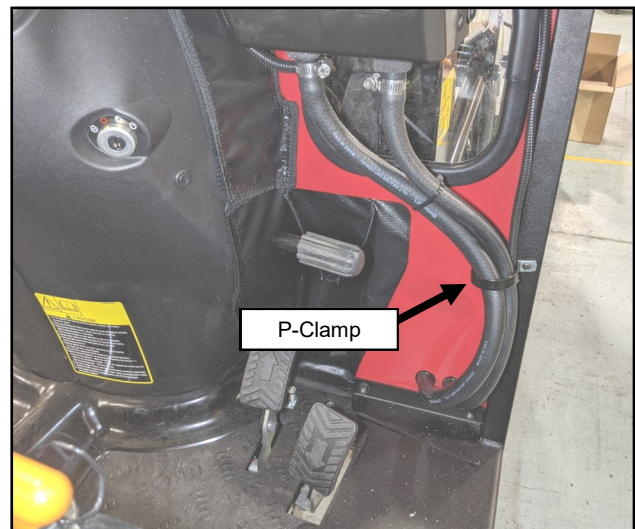

Fig. 18.16 (Connect Hose to Heater)

CAB INSTALLATION

STEP 19: (FINISH WIRING)

- 19.1** Use a supplied cable tie to secure the wiring harness to the heater hoses. See Figure 19.1.
- 19.2** Use two more cable ties to secure the wiring harness to the heater hoses near the fuel filter as well as to the battery cables running along the frame. See Figure 19.2.
- 19.3** Route the wiring harness around the front of the engine and secure to vehicle wiring with a cable tie. See Figure 19.3. Ensure the new wire harness will not contact the engine fan, pulleys, or exhaust.

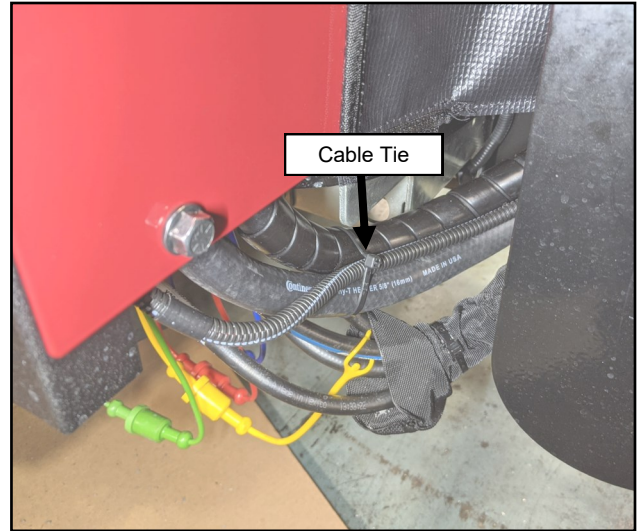

Fig. 19.1 (Secure Wiring Harness to Heater Hoses)

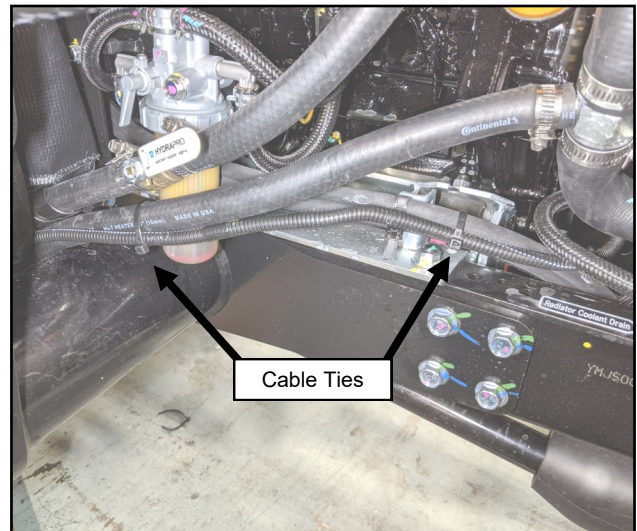

Fig. 19.2 (Secure Wiring Harness to Heater Hoses)

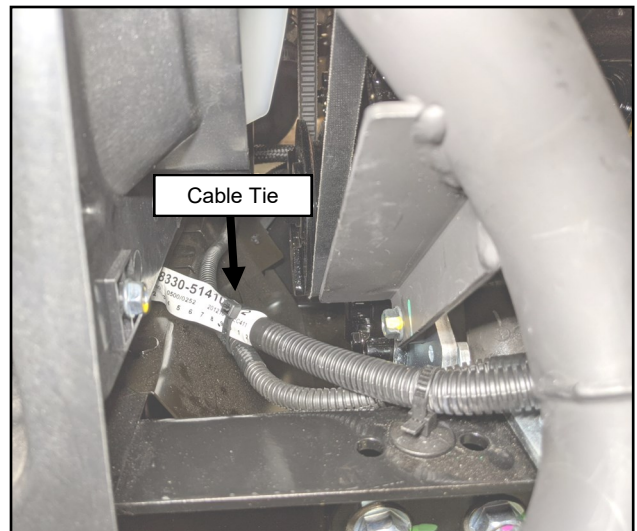

Fig. 19.3 (Route Wiring Harness In Front of Engine)

CAB INSTALLATION

STEP 19: (FINISH WIRING CONT'D)

19.4 Connect the ground terminal to the vehicle bracket shown in Figure 19.4.

Hardware Used

#10-32 x 1/2" Phillips Screw

#10-32 Nut

Qty

1

1

Tools required

#2 Phillips screw driver

3/8" Socket or Wrench

19.5 Connect the supplied fuse harness ring terminal to the positive post on the back of the alternator. See Figure 19.5. Connect the red wire from the cab power harness to the other side of the fuse harness. Coil up excess harness and wire tie in place.

19.6 Refill coolant, connect battery, check system operation.

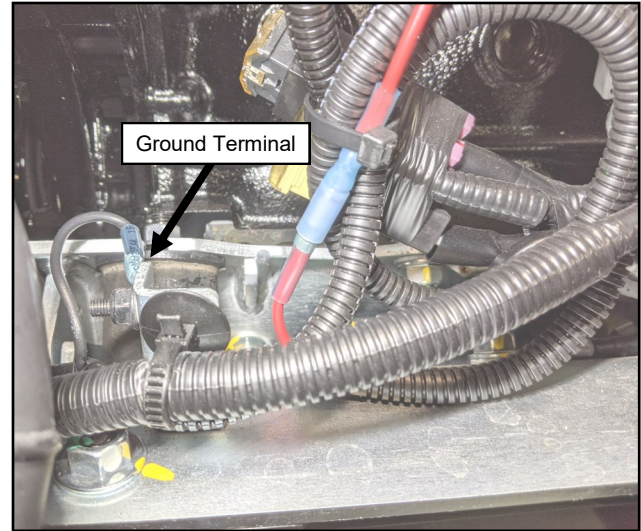

Fig. 19.4 (Connect Ground Terminal)

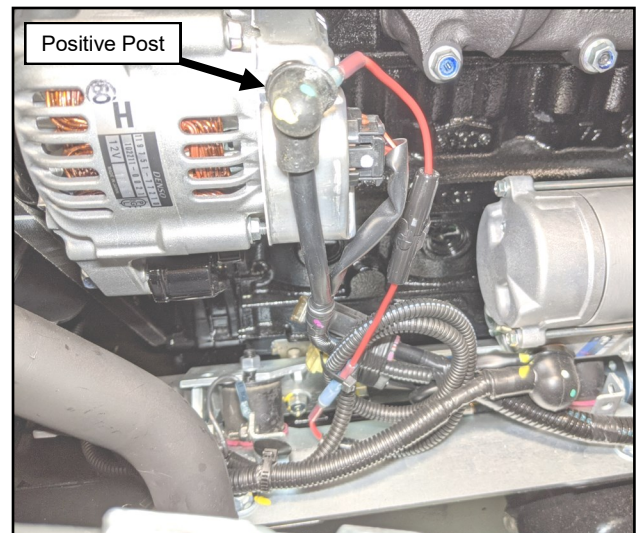

Fig. 19.5 (Connect Harness to Alternator)

STEP 20: (WIPER ARM AND BLADE)

20.1 Turn on the wiper motor briefly, then turn back off. This will make sure the motor shaft is in the correct parked position.

20.2 Pre-assemble the wiper arm and wiper blade.

20.3 Install the wiper arm onto the wiper motor so that the wiper is positioned as shown in figure 20.3. Tighten the set screws.

Tools required

2.5mm Allen Wrench

20.4 Adjust the length of the wiper arm as long as possible while still clearing the outer cap nut for the windshield latches. Turn on the wiper to check proper operation and to make sure the blade does not contact the windshield hinge at the top.

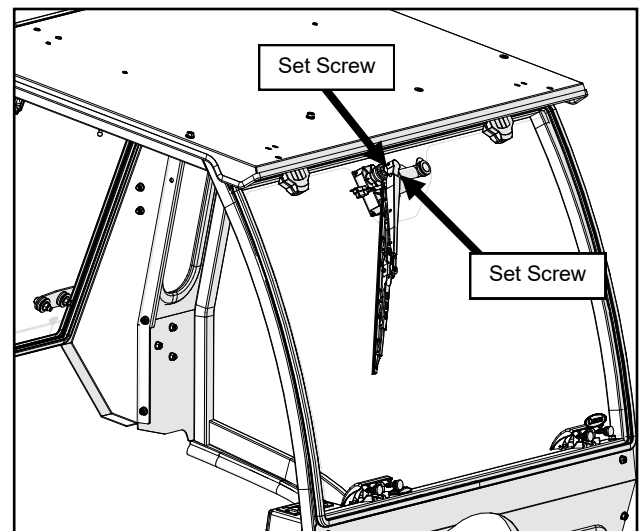

Fig. 20.3 (Wiper Arm and Blade)

CAB INSTALLATION

STEP 21: (UNDER SEAT FILLER)

NOTE: Open and or remove the glass rear panel for easier access.

- 21.1 Pre-install the supplied Velcro to the under seat filler. Leave the release tape on until the filler is in place.
- 21.2 Tip the seat forward and set the filler in place starting with the slits for the control levers on the left side. See Figure 21.2. Do not stick Velcro yet.
- 21.3 Fold and tuck the left rear corner under the rear leg. See Figure 21.3. Align the inner corner and inner edge to the rear leg and apply the Velcro.
- 21.4 Pull the left rear flap back and secure to the rear fender. See Figure 21.4. The flap should run close to the ROPS and turn inward to create a water channel.
- 21.5 Repeat steps 21.3 and 21.4 for the right rear corner.
- 21.6 If the rear panel was removed for easier access, re-install it at this time. Secure the rear of the filler to the glass rear panel. See Figures 21.6a and b.
- 21.7 Finally, ensure full movement of the control levers and secure the front half of the under seat filler. Do not cover any decals.

Note: Ensure the transition noted on Figure 21.3 prevents water intrusion. Adjustment may be necessary to keep water from running in.

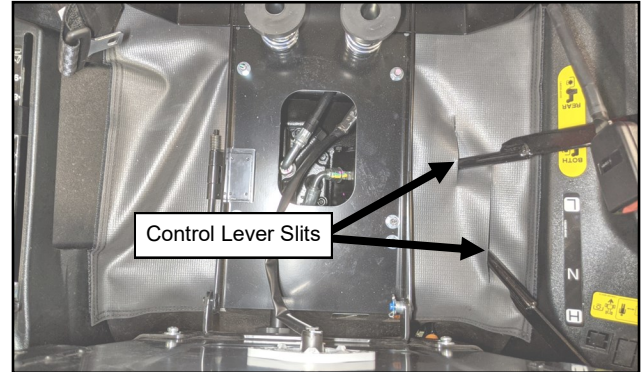

Fig. 21.2 (Set Filler In Place)

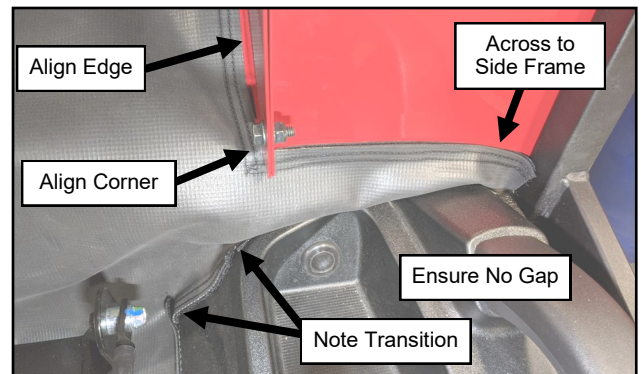

Fig. 21.3 (Secure Rear Left Corner)

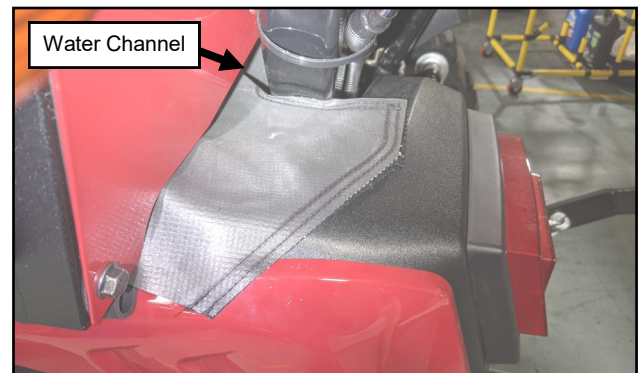

Fig. 21.4 (Secure Rear Flap)



Fig. 21.6b (Secure Filler to Rear Panel)



Fig. 21.6a (Secure Filler to Rear Panel)

CAB INSTALLATION

STEP 22: (ACCESSORIES)

22.1 Install any optional accessories at this time.

22.2 Optional Rear Wiper Note:

For easier wiper motor harness disconnection, cut the main wiring harness connector off a few inches from the end and create a jumper harness with it using bullet connectors. **Do not cut the connector off the wiper motor.**

Strip all the wires, crimp a male bullet connector onto the ground (black) wire of the main wire harness and a female bullet connector on the positive (red) wire.

Reverse the male and female bullet connectors on the new jumper wire harness so that the male bullet connector is on the positive (red) wire and the female bullet connector is on the ground (black) wire.

22.3 If a rear SCV was previously installed, refer to the Rear SCV Installation Instructions now for re-installation.

CAB INSTALLATION

STEP 23: (DOORS)

23.1 Install the supplied brass washers (one washer per pin) onto the hinge pins on the left side and then apply grease to the pins.

23.2 Loosen the door hinges to allow for adjustment later. Hang the left door on the hinges. While lifting up and forward on the door handle, line up the door latch with the striker pin and carefully attempt to latch. You should be able to hear 2 clicks as you slowly engage the latch on the pin. If the latch is too far forward or back to latch on the pin, adjust as shown. See Figures 23.2a through c. Then retighten and latch.

23.3 Stand back and examine the alignment of the door with the roof and the A-pillar. You can adjust this by moving the striker pin up or down as shown to help with alignment. *TIP: In the final step, the front of the door will drop a small amount the first time you open it. Set the front of the door a little bit higher so it aligns properly.* Adjust as necessary until you are happy with the alignment. Have an assistant sit inside the cab and once more carefully close the door like you did in step 23.2. Work with the assistant and tighten the hinge bracket bolts.

23.4 Open the door and check for smooth operation of the latch. As noted in step 23.3, the door will likely drop a little bit at the front and the striker pin will need to be adjusted down accordingly. Also make sure the door seal is making contact along the perimeter of the door and the latch clicks twice when closing. If necessary, adjust the striker in or out to achieve this.

23.5 With the door open, attach a gas strut to the ball studs on the side frame and door. Make sure the quick release end is on the side frame so that the gas strut stays with the door if removed for ventilation.

23.6 If installing a side mirror, do so now. Otherwise, install (2) supplied rubber grommets into the mirror holes.

23.7 Repeat steps 23.1 through 23.6 for the right door.

STEP 24: (FINISHING TOUCHES)

24.1 Due to the nature of the packaging materials used for shipping this product, the components of the cab system may have dust on their surfaces upon removal from the packaging. It is recommended that after completion of the cab installation, the cab and vehicle are washed thoroughly to eliminate any dust or contaminants. See the Care and Maintenance section at the back of this manual for critical information on cleaning the cab.

24.2 If equipped, re-install the SMV sign.

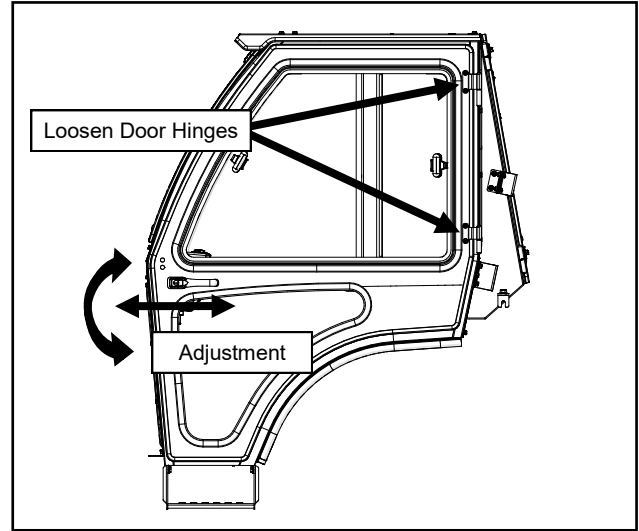

Fig. 23.2a (Door Hinge Adjustment)

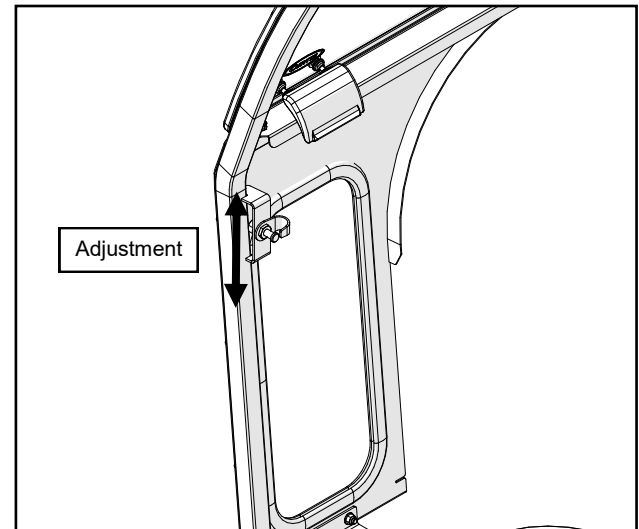

Fig. 23.2b (Striker Pin Adjustment)

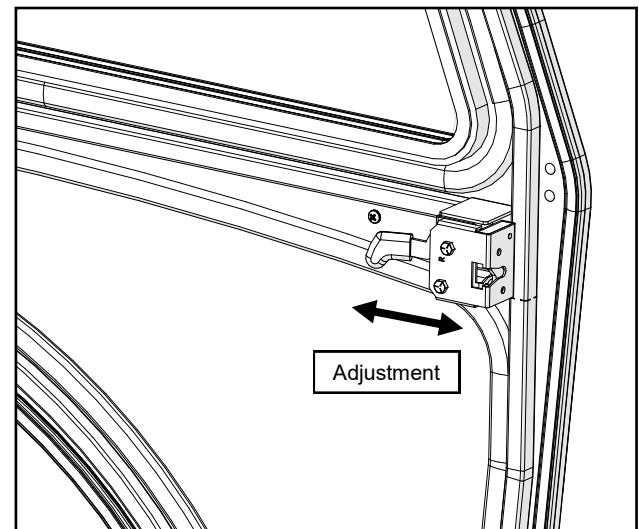
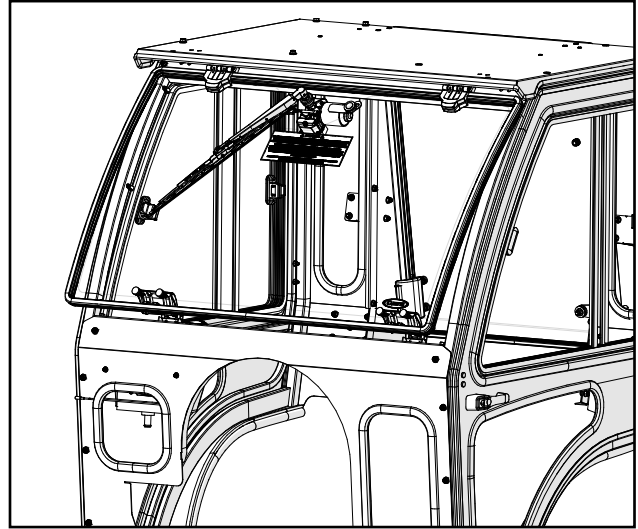

Fig. 23.2c (Door Latch Adjustment)

CAB FEATURES & OPERATION

POP-OUT WINDSHIELD

Your SA Series cab comes equipped with a pop-out windshield for ventilation. To open the windshield, simply lift up on both of the pop-out latches and rotate until the latches rest in the over-center position.



Pop-Out Windshield

LIFT-OFF DOORS

For added ventilation, the doors on the SA Series cab lift off in seconds without tools.

To lift off:

1. Disconnect the gas strut from the side frame by sliding the quick release lever and pulling the strut down.
2. Rotate the doors 90° to the cab and lift. Also, remove the hinge washers and store in a plastic bag.

Store the doors in a safe location to prevent damage.

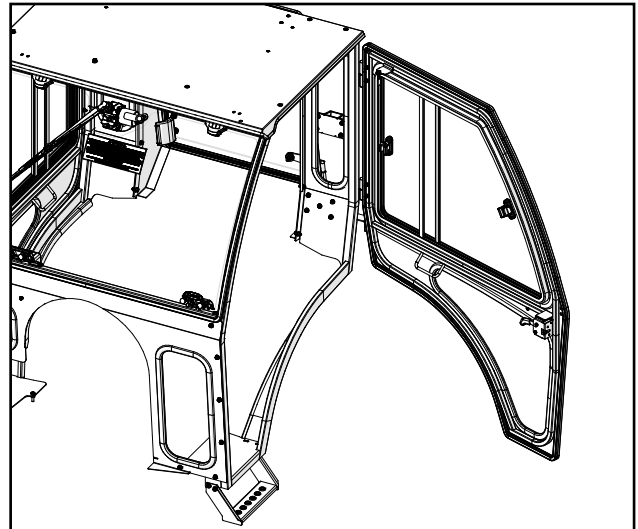

Lift-Off Doors

REMOVABLE REAR WINDOW

The rear window can also be removed for added ventilation.

To remove the rear window:

1. Open both window latches and disconnect from right rear leg with tabs on latch. Open the window taking care not to let the window open into the ROPS or damage may occur.
2. From outside of the cab, lift up on the rear window and slide off the hinges. Remove the hinge washers and store in a plastic bag.

Store the rear window in a safe location to prevent damage.

To reinstall the rear window, reinstall the hinge washers, align the hinges with the pins and drop into place. Re-attach the latches to the rear leg.

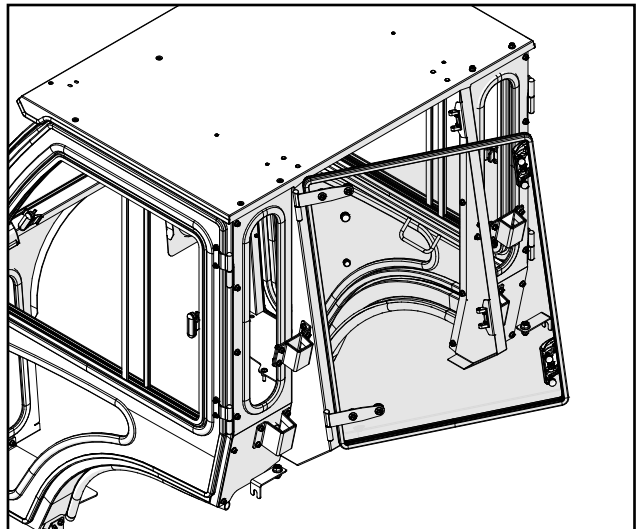

Removable Rear Window

CARE AND MAINTENANCE

- Re-apply lubrication (preferably grease) periodically as needed to the door striker pins, door latch assemblies, and the door hinges.
- Check and tighten hardware after 40 hours of operation. Periodically inspect and tighten hardware for the remainder of the unit's life.
- Wash the painted surfaces of the cab with commercial automotive cleaning products.
- Clean glass windows with glass cleaner. *Note: Some windows on the cab are acrylic. DO NOT* clean acrylic windows with harsh chemicals. It will damage the plastic. Mild soap and water should be used on all acrylic windows.
- Vinyl components should be washed with a mild solution of warm soapy water.

YANMAR SA SERIES CAB SERVICE PARTS

ROOF ASSEMBLY
P/N: 8SV-101-00061

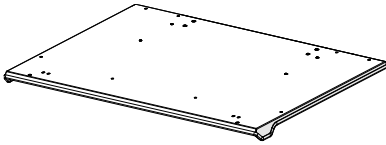

WINDSHIELD ASSEMBLY, 46.25" X 30.25"
P/N: 8SV-102-00038

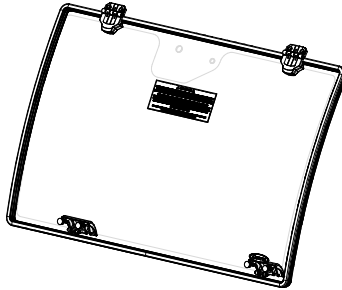

WINDSHIELD SUPPORT
P/N: 8SV-103-00027

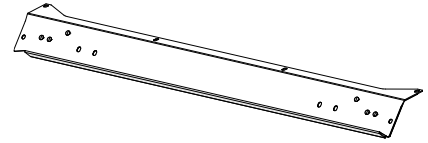

COWL ASSEMBLY
P/N: 8SV-105-00032

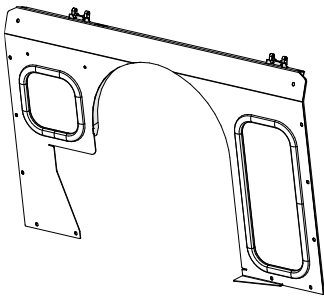

GLASS REAR PANEL LIFT OFF,
34.31 X 26.15, 3/16" THICK
P/N: 8SV-106-00021

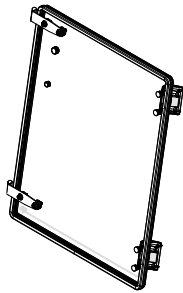

DOOR ASSEMBLY, LEFT
P/N: 8SV-107-00051-L

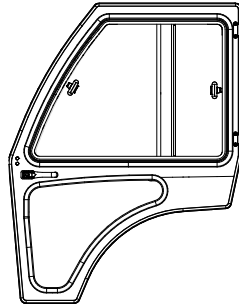

DOOR ASSEMBLY, RIGHT
P/N: 8SV-107-00051-R

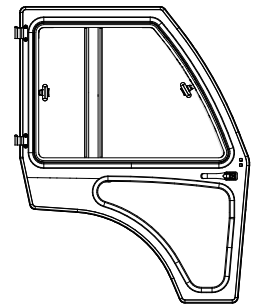

REAR LEG ASSEMBLY, LEFT & RIGHT
P/N: 8SV-108-00024-L & R

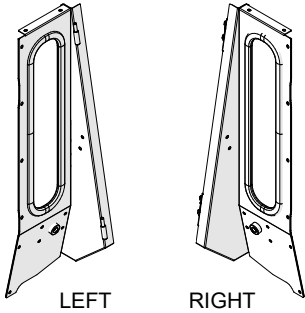

SIDE FRAME ASSEMBLY, LEFT
P/N: 8SV-109-00024-L

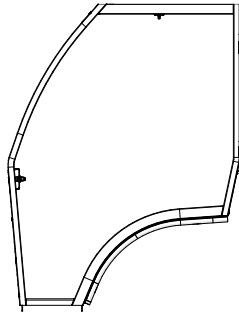

SIDE FRAME ASSEMBLY, RIGHT
P/N: 8SV-109-00024-R

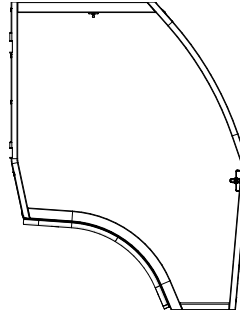

FLASHER RELOCATION BRACKET
P/N: 8SV-SM-02094

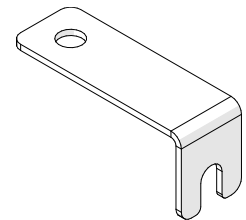

ROPS CLAMP ASSEMBLY, LOWER
P/N: 8SV-110-00098

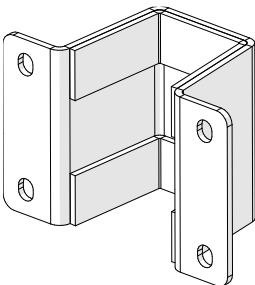

ROPS CLAMP ASSEMBLY, UPPER
P/N: 8SV-110-00099

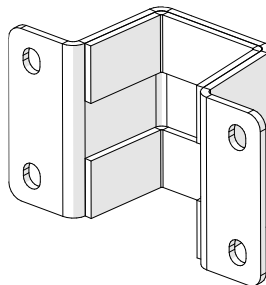

ROPS BRACKET ASSEMBLY
P/N: 8SV-110-00100

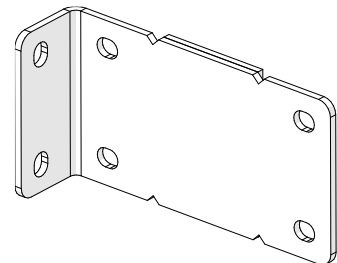

YANMAR SA SERIES CAB SERVICE PARTS

HEATER BRACKETS (1L & 1R)
P/N: 8SV-110-00101

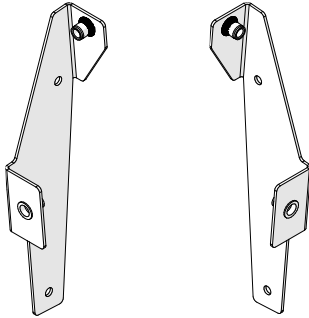

COWL FILLER ASSEMBLY, RIGHT
P/N: 8SV-112-00069

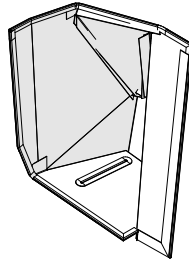

COWL FILLER ASSEMBLY, LEFT
P/N: 8SV-112-00070

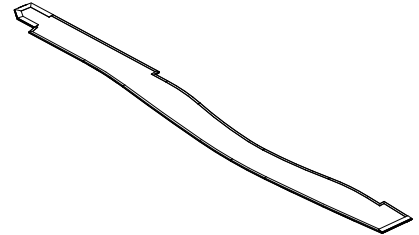

UNDERSEAT FILLER ASSEMBLY
P/N: 8SV-111-00036

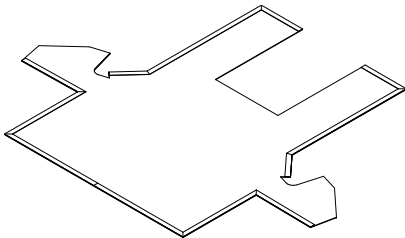

GLASS HINGE SLEEVE WITH
MOUNTING HARDWARE
P/N: 8SV-PL-00021

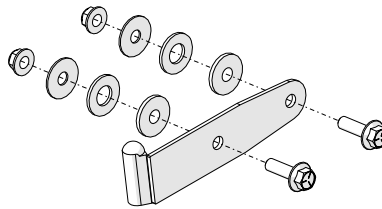

FRONT WINDOW, LEFT
P/N: 8SV-P-00141



FRONT WINDOW, RIGHT
P/N: 8SV-P-00142

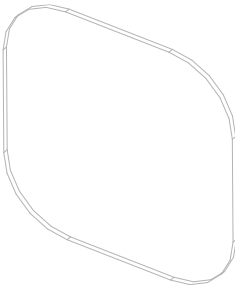

LOWER DOOR WINDOW
P/N: 8SV-P-00143



LEFT REAR
LEG WINDOW
P/N: 8SV-P-00144



RIGHT REAR
LEG WINDOW
P/N: 8SV-P-00180



SLIDING DOOR WINDOW, LEFT
P/N: 8SV-SWBX50L

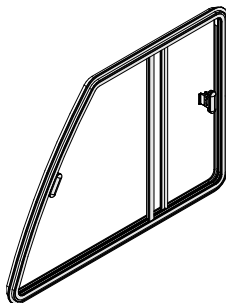

SLIDING DOOR WINDOW, RIGHT
P/N: 8SV-SWBX50R

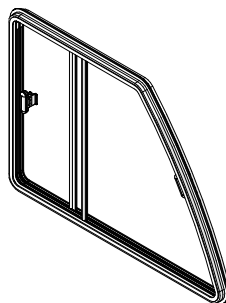







SCV FILLER TRIM RING
P/N: 8SV-SM-02559

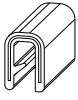

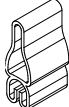
ADDITIONAL SERVICE PARTS

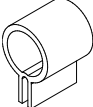
PART NUMBER	DESCRIPTION
9SV-DP11	DOME PLUG 1/2" (BAG OF 10)
9SV-DP10	DOME PLUG 3/8" (BAG OF 10)
9SV-HWSS	WINDSHIELD HINGE KIT WITH SHORT SPACER
9BLK01-S	WINDSHIELD HINGE BLOCK SPACER, SHORT STYLE, 5/8" THICK
9PWM110	WIPER MOTOR, 110 DEGREE
9PWB20-FB	WIPER BLADE, 20", FLEX
9PWA14-16	WIPER ARM, ADJUSTABLE LENGTH (11" - 16")
9PWK-HB	GLASS MOUNTING KIT FOR WIPER SYSTEMS
9SV-DSTRH	DOOR STRIKER KIT-INCLUDES CASE HARDENED STRIKER BOLT
9SV-IHRL	INSIDE HANDLE ROTARY LATCH KIT (INCL. L & R)
9SV-OHRL	OUTSIDE HANDLE ROTARY LATCH KIT (SET OF 2)
9SV-9PHW010-W	HINGE WASHER, KIT (SET OF 4) OD .635, ID .41, THK .08
9PI01	POLY INSERT 1", 14-20 GA BLK MATTE, INSERT FINS .94/.95 (QTY.: 1)
9PI02	POLY INSERT 3/4", 14-20 GA BLK MATTE FINISH, INSERT FINS 0.69 (QTY.: 1)
9SV-WL1	WINDSHIELD LATCH KIT 1, POPS OPEN W/S FOR VENTING ONLY
9SV-GS02Q	GAS SPRINGS, 12-3/8 EXT, QUICK DISCONNECT ENDS (SET OF 2)
9SV-9HR04	THICK PANEL SNAP BUSHINGS, .937ID X 1.093OD (SET OF 2)
9SV-9HR-00005	TEE FITTING, 1-1/8" x 1-1/8" x 5/8" (QTY.: ONE)
9SV-HR0049	90 DEGREE STREET ELBOW, 3/8" (QTY.: 2)
9SV-9HR0045	BLOCK ADAPTER (3/8" NIPPLE) (QTY.: 2)
9SV-9HR0048	ROCKER SWITCH (HI-OFF-LOW) (QTY.: ONE)
9SV-9HR0051MF	EXTENDED SENDING UNIT ADAPTER (QTY.: ONE)
9SV-9HR00601.0	HOSE CLAMPS #10 (1") (QTY.: 6)
9SV-9HR00601.5	HOSE CLAMPS #16 (1.5") (QTY.: 2)
9SV-HRH61-20	HEATER HOSE (5/8" I.D.)-20 FT
9SV-TBP12920	HARNESS (SPIRAL) WRAP, CUT 20" IN LENGTH
9SV-9HR-00025	IN-LINE MANUAL SHUT OFF VALVE, 3/4", NSF 14 (QTY.: ONE)
9SV-9HR-L	REPLACEMENT LOUVER-15,000 & 20,000 BTU HEATER (QTY.: ONE, WITH 2 SCREWS)
8SV-9PH20WG	TUCK-AWAY HEATER WITH WIRED GROUND
9PH20-2	FAN 120 x 120 x 38 12VDC 12W 3200 RPM
9SV-WH-00141	WIRING HARNESS EXTENDED WIPER LENGTH
8SV-WH-GF	WIRE HARNESS, GLASS FUSE (QTY.: ONE)
9DL01H	KEYS, SET OF 2 ON A RING, FOR HANDLE 1096-1, KEY CODE C40
8SV-HKWTB-L	HINGE KIT, TOP & BOT., LEFT
8SV-HKWTB-R	HINGE KIT, TOP & BOT., RIGHT

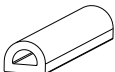
TRIM LOK, STD, 1/16" - 1/8" GRIP	5/8" STD BULB, 1/16" GRIP	1" FLAT BULB, 1/16" GRIP	ARCH PSA RUBBER	WINDOW RUBBER	1" STD BULB, 1/16" GRIP	2" SPONGE RUBBER	3/4" SIDE BULB, 1/4" GRIP	ARCH PSA .2 X .15
								
9SV-PRO1-10	9SV-PRO2-15	9SV-PRO5-10	9SV-PRO9-10	9SV-PR10-10	9SV-PR19-10	9SV-PR35-5	9SV-PR38-15	9SV-PR53-15

OPTIONAL ACCESSORIES FOR YANMAR SA SERIES CAB

FRONT LED WORK LIGHTS (P/N: 9LEDW4)

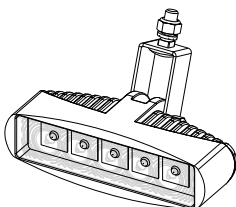

REAR LED WORK LIGHTS (P/N: 9LEDW3)

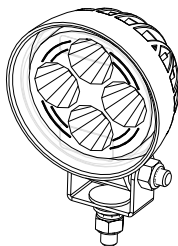

STROBE LIGHT (P/N: 9LEDS2)

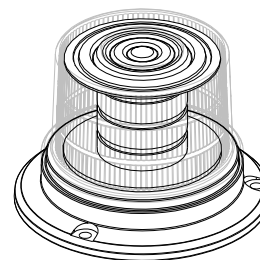

DOME LIGHT (P/N: 9LEDD14)

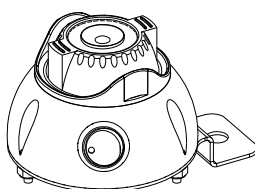

SIDE VIEW MIRRORS (P/N: 9PM5)

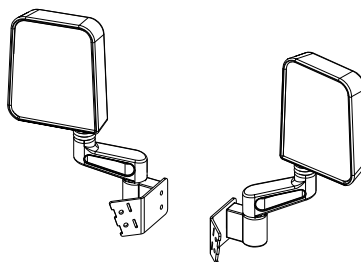

REAR VIEW MIRROR (P/N: 9PM3)

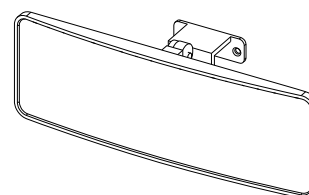

REAR WIPER KIT, 85 DEG W/ 12" FLEX BLADE (P/N: 9PWK8512F9-11A)

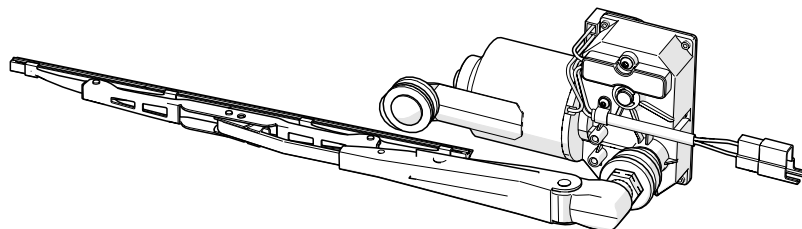

Tightening of Non-Structural Bolts

For light or medium duty fastening, Curtis recommends using a general industry standard of tightening until snug and then giving an additional one quarter turn of the tool as deemed reasonable for the application (i.e.: at the installer's discretion).

If torque values are required, the examples listed below are intended as a reasonable reference for use in the majority of non-structural fastener applications such as: small diameter fasteners; bolts passing thru tubing, glass, plastic, nylon or rubber washers, threaded inserts, etc.



If more than one application below applies, use the lower torque value.

FASTENER SIZE:	FASTENER TYPE:	WASHER MATERIAL:	APPLICATION:	TORQUE (INCH-POUNDS) (±5)
#10	Machine Screws	-	in Nylon P-Clamps	20
#10	Machine Screws	-	Strobe Light (plastic base)	35
M5	Set Screws	-	Wiper Arm	20
1/4"	Cap Nut	-	Windshield Wiper	20
1/4"	Bolts	-	Tubing (5/8" to 3/4" wide)	132
1/4"	Bolts	Rubber	-	60
1/4"	Bolts	Nylon / Plastic	-	72
1/4"	Bolts	-	Factory Installed Threaded Inserts	132
5/16"	Bolts	-	Tubing (1" or wider)	60
5/16"	Flat Head Bolts	-	Plastic Windshield Hinge	79
5/16"	Bolts	Rubber	-	120
5/16"	Bolts	Nylon / Plastic	-	150
5/16"	Ball Studs	-	-	150
5/16"	Bolts	-	Factory Installed Threaded Inserts	240
3/8"	Bolts	-	Tubing	120
M12	Door Striker Pins	-	-	120

Torque Specs. for Structural Bolts

This page is for use primarily when dealing with high-strength vehicle fasteners such as ROPS hardware that hold the structure together for safety. This page can also be used for other solid metal-to-metal joints. **Do not** use these high torque values on any of the following applications involving: tubing, plastic, nylon or rubber washers, threaded inserts, etc.. See previous page regarding less critical fasteners.

The values below apply to fasteners that are dry or lubricated with normal engine oil. They do not apply if special graphited or moly disulphide greases or other extreme pressure lubricants are used. This applies to both UNF and UNC threads. Remember to always use the same grade or property class when replacing bolts.

SAE Grade No.		2				5				8*			
Bolt head identification mark as per grade.													
NOTE: Manufacturing Marks Will Vary													
Bolt Size		TORQUE				TORQUE				TORQUE			
		Pounds Feet		Newton-Meters		Pounds Feet		Newton-Meters		Pounds Feet		Newton-Meters	
Inches	Millimeters	Min.	Max.	Min.	Max.	Min.	Max.	Min.	Max.	Min.	Max.	Min.	Max.
1/4	6.35	5	6	7	8	9	11	12	15	12	15	16	20
5/16	7.94	10	12	14	16	17	20.5	23	28	24	29	33	39
3/8	9.53	20	23	27	31	35	42	48	57	45	54	61	73
7/16	11.11	30	35	41	47	54	64	73	87	70	84	95	114
1/2	12.70	45	52	61	70	80	96	109	130	110	132	149	179
9/16	14.29	65	75	88	102	110	132	149	179	160	192	217	260
5/8	15.88	95	105	129	142	150	180	203	244	220	264	298	358
3/4	19.05	150	185	203	251	270	324	366	439	380	456	515	618
7/8	22.23	160	200	217	271	400	480	542	651	600	720	814	976
1	25.40	250	300	339	406	580	696	787	944	900	1080	1220	1464
1-1/8	25.58	-	-	-	-	800	880	1085	1193	1280	1440	1736	1953
1-1/4	31.75	-	-	-	-	1120	1240	1519	1681	1820	2000	2468	2712
1-3/8	34.93	-	-	-	-	1460	1680	1980	2278	2380	2720	3227	3688
1-1/2	38.10	-	-	-	-	1940	2200	2631	2983	3160	3560	4285	4827

*Thick Nuts must be used with Grade 8 bolts

METRIC BOLT TORQUE SPECIFICATIONS



Size of Screw	Property Class	Course Thread			Fine Thread		
		Pitch (mm)	Pounds Feet	Newton-Meters	Pitch (mm)	Pounds Feet	Newton-Meters
M6	5.6	1.0	3.6-5.8	4.9-7.9	-	-	-
	8.8		5.8-9.4	7.9-12.7		-	-
	10.9		7.2-10	9.8-13.6		-	-
M8	5.6	1.25	7.2-14	9.8-19	1.0	12-17	16.3-23
	8.8		17-22	23-29.8		19-27	25.7-36.6
	10.9		20-26	27.1-35.2		22-31	29.8-42
M10	5.6	1.5	20-25	27.1-33.9	1.25	20-29	27.1-39.3
	8.8		34-40	46.1-54.2		35-47	47.4-63.7
	10.9		38-46	51.5-62.3		40-52	54.2-70.5
M12	5.6	1.75	28-34	37.9-46.1	1.25	31-41	42-55.6
	8.8		51-59	69.1-79.9		55-68	75.9-92.1
	10.9		57-66	77.2-89.4		62-75	84-101.6
M14	5.6	2.0	49-56	66.4-75.9	1.5	52-64	70.5-86.7
	8.8		81-93	109.8-126		90-106	122-143.6
	10.9		96-109	130.1-147.7		107-124	145-168
M16	5.6	2.0	67-77	90.8-104.3	1.5	69-83	93.6-112.5
	8.8		116-130	157.2-176.2		120-138	162.6-187
	10.9		129-145	174.8-196.5		140-158	189.7-214.1
M18	5.6	2.0	88-100	119.2-136	1.5	100-117	136-158.5
	8.8		150-168	203.3-227.6		177-199	239.8-269.6
	10.9		175-194	237.1-262.9		202-231	273.7-313
M20	5.6	2.5	108-130	146.3-176.2	1.5	132-150	178.9-203.3
	8.8		186-205	252-277.8		206-242	279.1-327.9
	10.9		213-249	288.6-337.4		246-289	333.3-391.6