

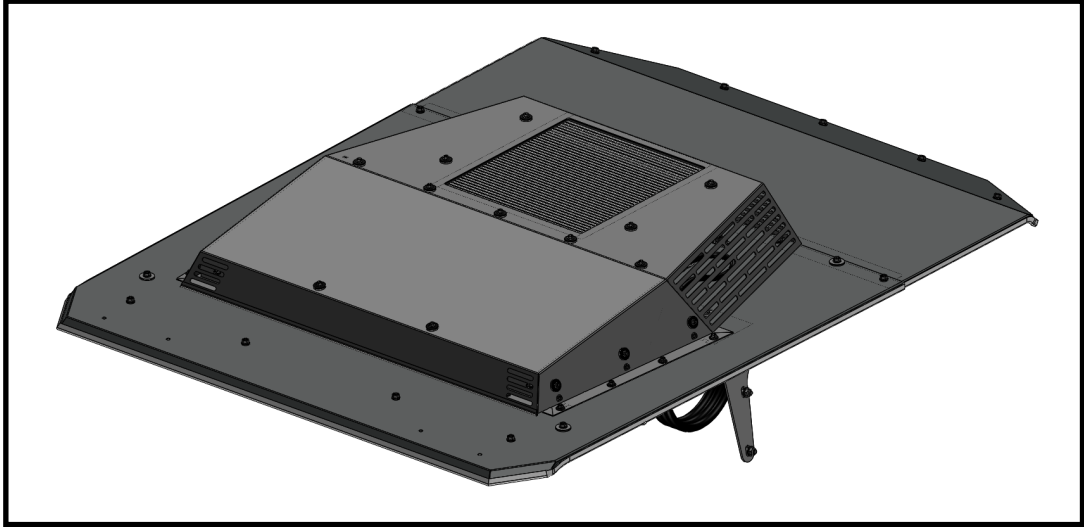

**John Deere XUV S4, 855 (Diesel), 2013-
A/C Kit**
P/N: 1GTRXUV4ACRKD



Approximate Installation Time *
Experienced Dealer Technician – 4-6 Hours
Average Dealer Technician – 6-8 Hours
Do-It-Yourself – Not Recommended

Approximate Product Specifications
Ground to Top of Air Conditioner: 84 inches
Weight: 169 lbs.
Shipping Weight: 350 lbs (1GTRXUV4ACRKD)

Register your new product quickly online at Curtiscab.com/product-registration/



Curtis encourages all customers to register their Curtis products. However, failure to do so will not diminish right to warranty. Curtis Industries does not sell or share your information with anyone else.

Download a digital copy of your installation instructions online at Curtiscab.com/literature/



Curtis strives to continuously improve our products, technical documentation, etc. Therefore, the installation manual for this product may have been updated after your product was packaged. The latest revision of the installation manual can always be found at the website above.

The contents of this envelope are the property of the owner. Leave with the owner when installation is complete.

TABLE OF CONTENTS

WARNINGS, TIPS, & REQUIRED TOOLS.....	3
KIT INSTALLATION	4-21
CARE AND MAINTENANCE.....	22
TROUBLESHOOTING.....	22
SERVICE PARTS	23-27
WIRING SCHEMATIC.....	28
BOLT TORQUE SPECIFICATIONS	29





WARNINGS, TIPS, & REQUIRED TOOLS

Curtis accessories feature an assembly of parts designed for your vehicle which require adjustment and alignment of components to accommodate vehicle variations and provide proper operation. For accurate installation, proper operation, and years of satisfaction, please read and understand the installation and owner's manual fully prior to installing the item.

From all of us at Curtis, we thank you for choosing our product.

 NOTICE
<p>Curtis Cabs, blades and general accessories add additional weight to the base vehicle. All Curtis accessory weights are listed in product brochures. Deduct the accessory's total weight from the vehicle's rated capacity and never exceed the vehicle's rated capacity including driver and passenger.</p>

<p>WARNING Exposure to Carbon Monoxide can Cause illness, serious injury or death. Never operate vehicle if suspicious of Carbon Monoxide. Inspect exhaust system for leaks monthly. Leaks can result from loose connections, corrosion, cracks or other damage to the exhaust manifold. If leaks are found, repair or replace exhaust system. Do not use vehicle until repair or replacement is complete.</p>

 WARNING	
Serious Injury or Death	
	This cab enclosure does not provide protection from rollover or other accidents.
	This cab enclosure does not provide protection from flying objects including golf balls.
	This cab enclosure does not provide protection from lightning. When lightning threatens take cover and do not operate vehicle.

GENERAL INFORMATION BEFORE YOU START

HELPFUL HINTS:

- Refer to parts diagram found in the service parts section of this manual to help identify parts during the assembly process.
- To assist with the installation, leave all fasteners loose for later adjustment unless otherwise specified.
- Read and understand all instructions before beginning.
- Apply a silicone sealant to seal any minor gaps that may occur due to vehicle variations.
- Use caution to avoid damaging the factory installed threaded inserts or weld nuts. Begin the thread engagement by hand to avoid or correct potential cross threading.
- Make sure the areas where the supplied self-adhesive foam will be applied are clean and dry and at room temperature for best adhesion.

TOOLS REQUIRED:

- | | |
|---|--|
| <ul style="list-style-type: none"> • Set of Standard and Metric Sockets (3/8" Drive) • 3/8" Drive Cordless Ratchet and Long Drive Extension • Set of Standard and Metric Open-End Wrenches • Torque Wrenches • 23mm Socket and Driver • Refrigerant Machine • R134a Refrigerant • Electrical Tape • T30 & T40 Torx Drivers • Crows foot wrenches 22mm & 27mm (or 7/8" and 1-1/16") • Thread Sealer (Permatex 56521 or Equivalent) • Loctite 242 • 5/16" Nut Driver • 10mm Deep Socket • Pliers | <ul style="list-style-type: none"> • Drill • 3/16" Drill Bit • Utility Knife • Pair of Scissors • Cutoff Tool (Dremel) • Tape Measure • Snips • Fir Clip Remover • Flat Blade Screw Driver • Phillips Head Screw Driver • Strap Wrench • Sharpie or China Marker • 10mm Ratcheting Wrench • Metric Allen Wrenches • Punch • Hammer • Pick or Small Screw Driver |
|---|--|

A/C INSTALLATION

SET UP:

Unpack all parts. Parts wrapped in felt have labels on them. Keep parts with these labels to be identified properly. Spread parts around work area as space allows and check for shipping damage.

Locate all necessary tools from the list on the previous page and layout on work bench or table before beginning. Open up the main hardware kit and separate and organize the hardware.

For vehicles with cab installed, you should remove and discard the front & rear roofs. Remove and set aside the doors.

STEP 1: (VEHICLE PREP)

- 1.1 Rotate rear seat bottom up, remove and set aside. Disconnect power cables from battery. See fig. 1.1.

Tools Required:

13mm Socket or wrench

- 1.2 Remove the rear lower kick panel, set aside along with its hardware. See fig. 1.2.

Tools Required:

T40 Torx driver

- 1.3 Remove rear center console and set aside it and the (4) plastic dart clips retaining it. See Fig. 1.2.

Tools Required:

Fir Clip Remover

- 1.4 Remove the front seat and set aside.

- 1.5 Per fig. 1.5, mark & cut the plastic vehicle panel under the front seat on the right side as shown. (**2-1/2" outboard & 1" down**).

Tools Required:

Tape measure

Sharpie or China marker

Utility knife

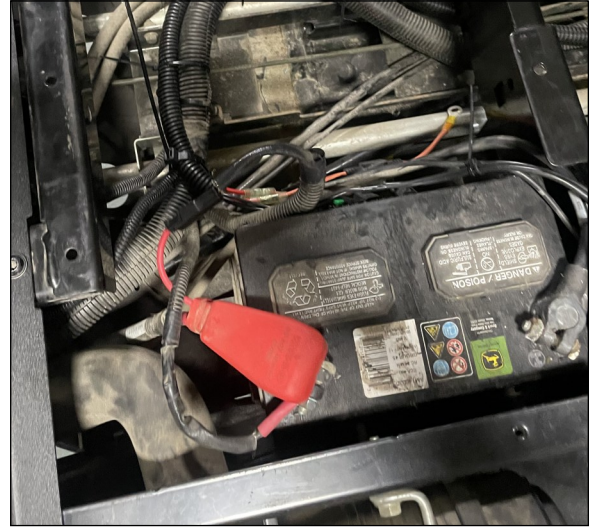

Fig. 1.1 Disconnect Battery

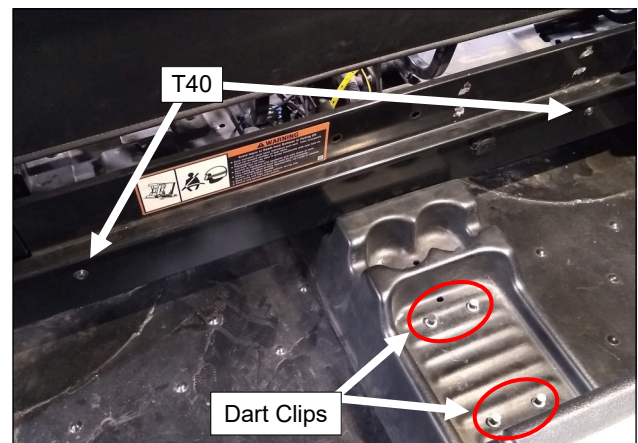

Fig. 1.2 Lower Kick Panel and Rear Center Console

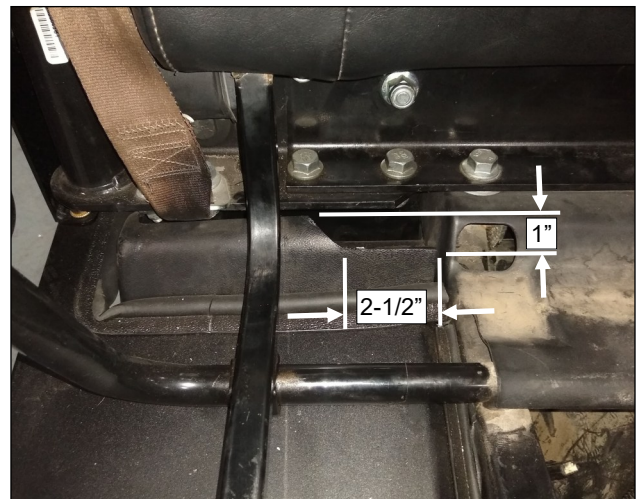

Fig. 1.5 Right Side Vehicle Panel

A/C INSTALLATION

STEP 1: (VEHICLE PREP)

- 1.6 Per fig. 1.6, install the supplied (narrow grip) Trim-Lok along the previously cut edge of the right side vehicle plastic.
- 1.7 Install the supplied (wide grip) Trim-Lok along the metal edge as shown in Fig. 1.6.
- 1.8a Orient the supplied draft barrier under hood as shown in fig. 1.8a.
- 1.8b Install the supplied Velcro to the steel frame components around the perimeter of the vinyl. Use the vinyl panel as a guide for Velcro location.
*Note: The steel frame components **must** be cleaned and should be at room temperature for best adhesion.*
- 1.8c Depending on vehicle or other accessory routing, you may need to cut the vinyl to best fit with any obstacle. *Note: If installing with heater, use draft barrier contained in heater kit.*
- 1.9 *Per the OEM service manual*, remove the cargo bed. Disconnect any wiring that is tied to or connected with the bed.

Tools Required:

- 18mm Socket
- 18mm wrench
- Punch (manual lift)
- Hammer (manual lift)
- Pick or small screwdriver (manual lift)

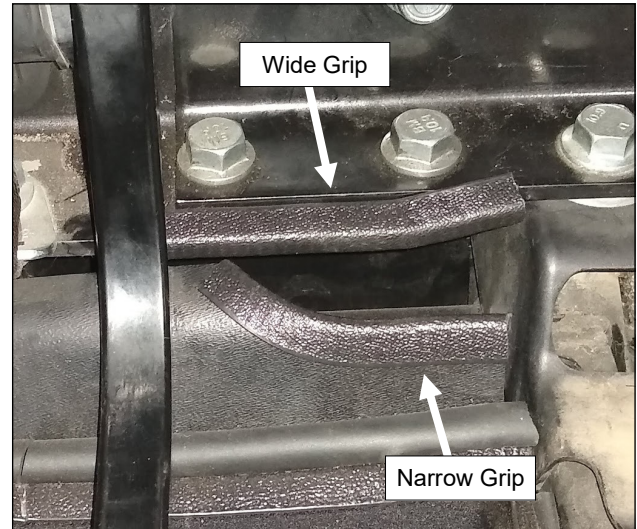

Fig. 1.6 Trim-Lok



Fig. 1.8a Draft Barrier

A/C INSTALLATION

STEP 1: (VEHICLE PREP)

- 1.10 Remove and set aside the (2) sets of fasteners on the left side of the vehicle retaining the seat back as shown. See fig. 1.10.

Tools Required:

18mm Socket and wrench

- 1.11 Remove and set aside the (2) remaining sets of fasteners on the right side of the vehicle retaining the seat back.

Tools Required:

18mm Socket and wrench

- 1.12 Remove and set aside the (8) sets of fasteners securing the lower cross brace to ROPs and vehicle frame. Set the cross brace aside and all hardware. See fig. 1.12.

Tools Required:

18mm Socket and wrench

- 1.13 Remove debris shroud and set aside its hardware for future use. The debris shroud itself can be discarded. See fig. 1.13.

Tools Required:

T40 Torx bit

- 1.14 Remove and set aside the C-clip retaining the throttle cable to its bracket. Remove and discard the bracket and fasteners from the engine block. See fig. 1.14.

Tools Required:

Flat blade screw driver

15mm Socket

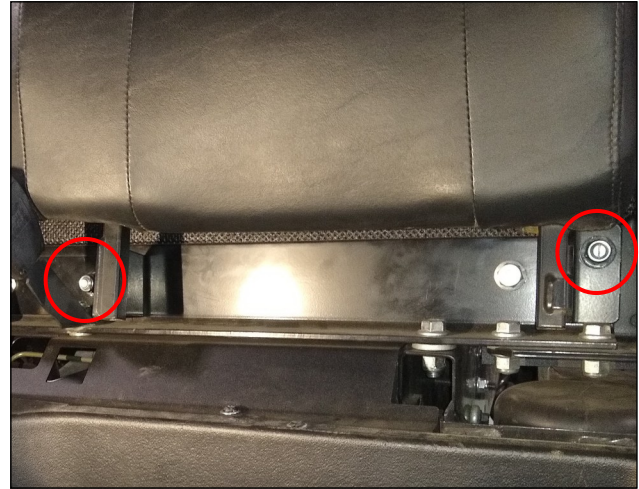

Fig. 1.10 Left Side Seat Back Fasteners



Fig. 1.12 ROPS / Cross Brace Fasteners

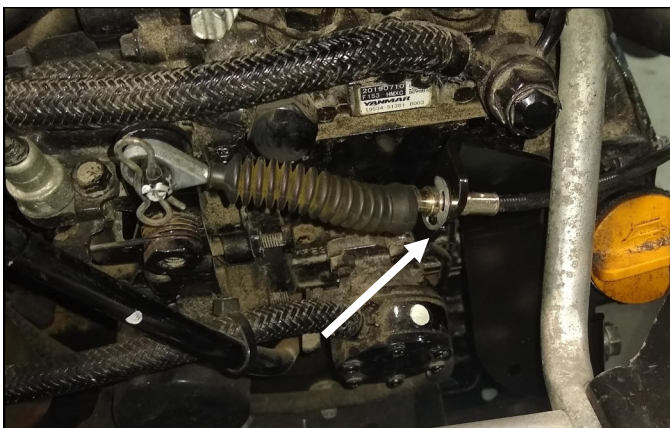

Fig. 1.14 Throttle Cable Bracket

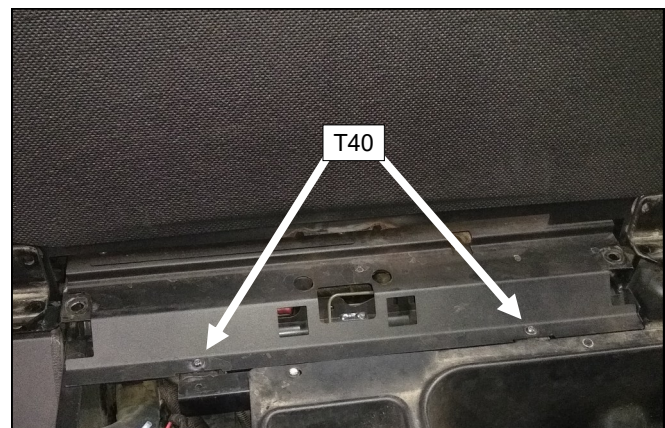

Fig. 1.13 Debris Shroud and Hardware

A/C INSTALLATION

STEP 1: (VEHICLE PREP)

- 1.15 Remove and set aside the transmission cable retaining clip. See fig. 1.15.

Tools Required:
Flathead Screwdriver
Pliers

- 1.16 Loosen the bolt securing the engine/transmission strap to the engine.

Tools Required:
13mm Socket

- 1.17 Remove and set aside the (2) bolts securing the engine/transmission strap and transmission cable bracket to the transmission. Remove and discard the transmission cable bracket. See Figure 1.15.

Tools Required:
15mm Socket

- 1.18 Remove the ball stud from the transmission lever and reinstall the ball stud on the opposite side of the transmission lever. See fig. 1.18.

Tools Required:
13mm Socket
13mm Wrench

- 1.19 Disconnect Air Intake from the engine. See fig. 1.19.

Tools Required:
5/16" Nut driver or flat blade screw driver

- 1.20 Disconnect drive shaft from the transmission and remove and set aside the (2) fasteners securing the intermediate bearing. See fig. 1.20.

Tools Required:
15mm Socket
T30 Torx bit

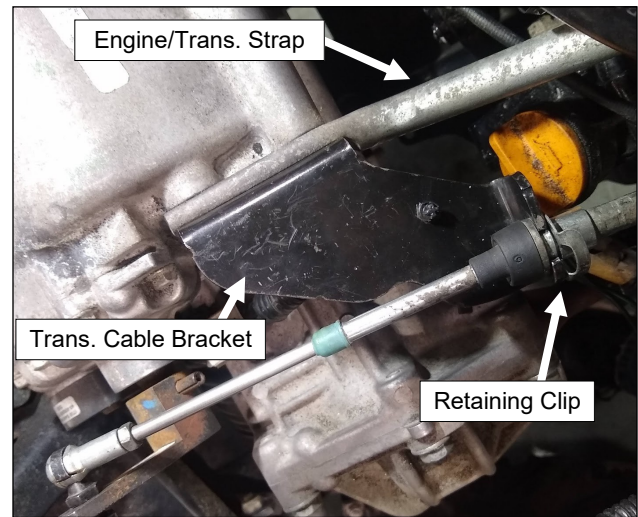

Fig. 1.15 Transmission Cable Retaining Clip



Fig. 1.18 Trans Ball Stud Reorientation

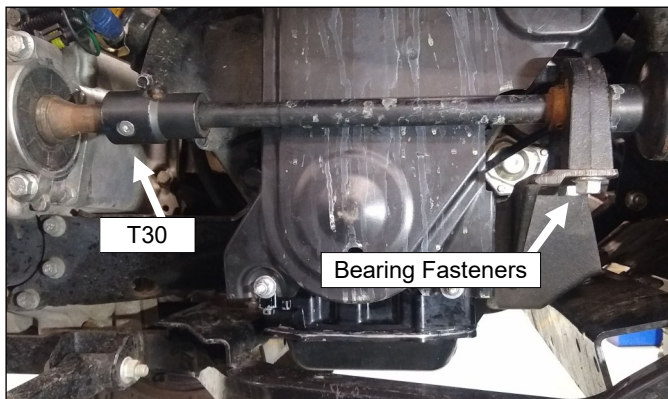

Fig. 1.20 Driveshaft and Intermediate Bearing



Fig. 1.19 Intake Hose

A/C INSTALLATION

STEP 1: (VEHICLE PREP)

- 1.21 Remove the (4) nuts and washers along with the J-hook from belt cover. Set J-hook aside for future use. Hardware may be discarded. See figures 1.21 & 1.22.

Tools Required:

10mm Deep socket & wrench

- 1.22 Remove the plastic belt cover from above. Belt cover may be discarded.

- 1.23 Remove and discard the remaining washers on the studs and remove and discard all 3 studs. See fig. 1.23.

Tools Required:

10mm Deep socket & pliers

- 1.24 Replace lower left stud with bolt and washer. See fig. 1.24. **Note: Apply thread sealer & Torque to 6 ft lbs.**

Tools Required:

10mm Socket

Hardware:

M6x1.0 x 65mm hex head bolt
M6 x 12mm flat washer

Qty:

1
1

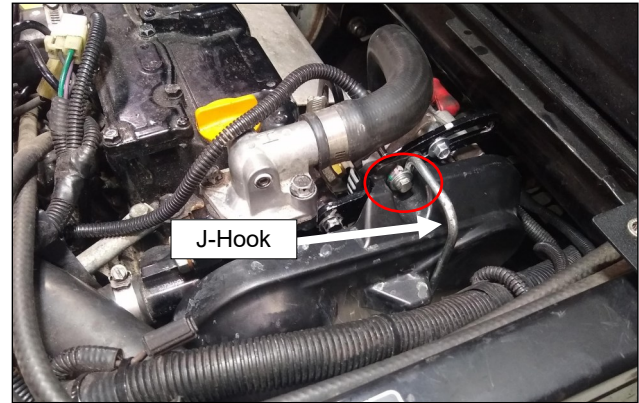

Fig. 1.21 J-Hook

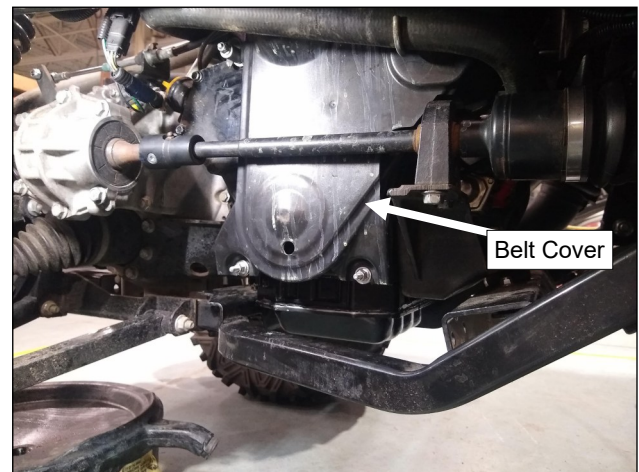

Fig. 1.22 Belt Cover



Fig. 1.24 Lower Left Stud Replacement

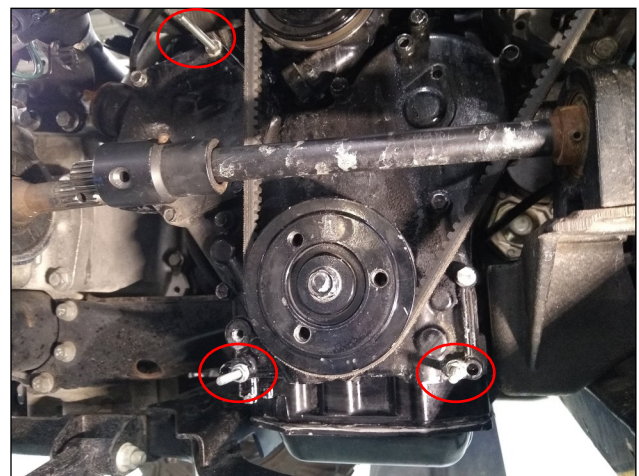

Fig. 1.23 Studs

A/C INSTALLATION

STEP 1: (VEHICLE PREP)

- 1.25 Replace upper left stud with adjacent cover fastener. See fig. 1.25. **Note: Apply thread sealer & Torque to 6 ft lbs.**

Tools Required:
10mm Socket

- 1.26a Disconnect alternator wiring. See fig. 1.26a.

Tools Required:
10mm Ratcheting wrench

- 1.26b Remove alternator, bracket, and the bolt directly below the alternator bracket. The bracket and hardware may be discarded. See fig. 1.26b.

Tools Required:
12mm, 13mm & 14mm sockets

- 1.26c Remove and set aside the OEM alternator pulley and spacer behind the pulley. See fig. 1.26c.

Tools Required:
18mm Socket

- 1.27 Remove the water pump pulley and its hardware. The hardware may be discarded. See fig. 1.27.
Note: Strap wrench may be helpful to hold pulley.

Tools Required:
10mm Ratcheting wrench



Fig. 1.25 Engine Cover Fasteners



Fig. 1.26a Alternator Wiring



Fig. 1.26c OEM Alt. Pulley and Spacer



Fig. 1.27 Water Pump Pulley

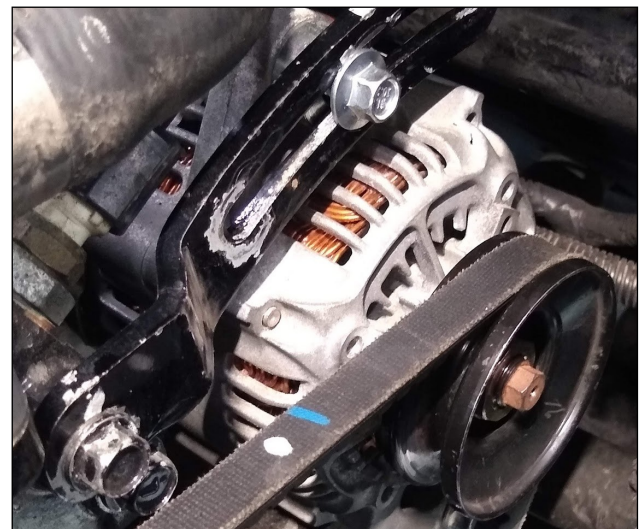

Fig. 1.26b OEM Alternator

A/C INSTALLATION

STEP 2: (ALTERNATOR)

- 2.1 Install lower alternator mount. *Note: Longer bolt and lock nut are installed through the rearmost hole.* See fig. 2.1. **Torque to 30 ft lbs.**

Tools Required:
M8 Allen Wrench
15mm Wrench

<u>Hardware:</u>	<u>Qty:</u>
M10x1.5 x 75mm socket head bolt	1
M10x1.5 x 110mm socket head bolt	1
M10 x 18mm flat washer	2
M10x1.5 flange lock nut	1

- 2.2 Remove and discard the pulley on the supplied alternator. See fig. 2.2.
Install OEM alternator spacer and pulley (removed in step 1.26c) onto the Curtis supplied alternator.
Torque pulley nut to 30 ft lbs.

Tools Required:
22mm Socket

- 2.3 Install alternator to the previously installed lower alternator mount. *Leave fasteners loose at this time.*

Tools Required:
15mm Socket
15mm Wrench

<u>Hardware:</u>	<u>Qty:</u>
M10x1.5 x 100mm flange head bolt	1
M10x1.5 flange lock nut	1

- 2.4 Per fig. 2.4, install alternator adjustment bracket and spacers to the engine block. **Apply thread sealer to lower bolt and torque both bolts to 20 ft lbs.** *Note: Shorter bolt belongs in the upper hole.*

Tools Required:
13mm Socket

<u>Hardware:</u>	<u>Qty:</u>
M8x1.25 x 35mm flange head bolt	1
M8x1.25 x 70mm flange head bolt	1
3/4" OD x 1/2" long aluminum spacer	2

- 2.5 Install upper alternator to adjustment bracket fastener. *Leave loose at this time.* Reinstall alternator power wire removed in step 1.26a. *Leave control wiring disconnected for now.*

Tools Required:
13mm Socket
10mm Ratcheting wrench

<u>Hardware:</u>	<u>Qty:</u>
M8x1.25 x 25mm flange head bolt	1



Fig. 2.1 Lower Alternator Mount

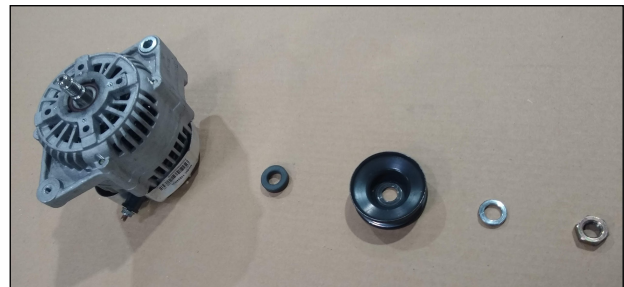

Fig. 2.2 Alternator Spacer and Pulley

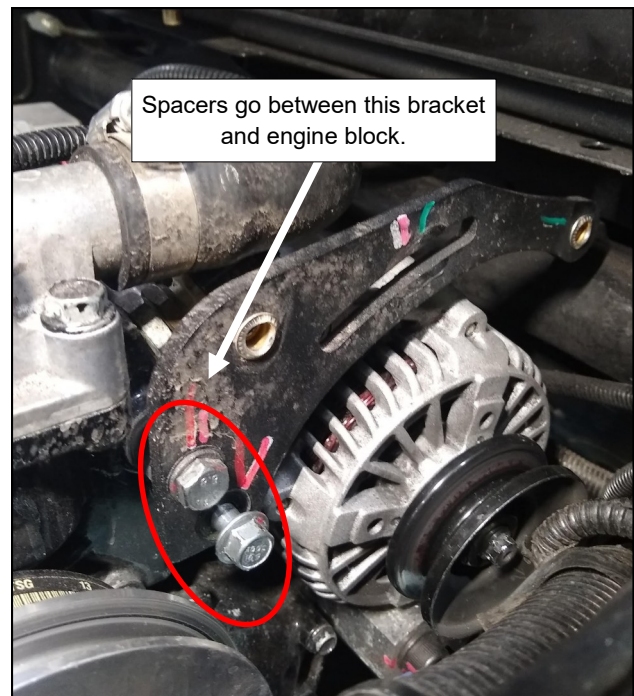

Fig. 2.4 Alternator Adjustment Bracket

A/C INSTALLATION

STEP 2: (ALTERNATOR)

- 2.6 Per fig. 2.6, thread the supplied studs into water pump. Install OEM and supplied water pump pulleys and **torque lock nuts to 8 ft lbs.**

Caution: apply Loctite 242 to threads of nuts.

Tools Required:

10mm Socket or Ratcheting Wrench

Hardware:

M6x1.0 X 27.5mm stud
M6 x 12mm flat washer
M6x1.0 lock nut

Qty:

4
4
4

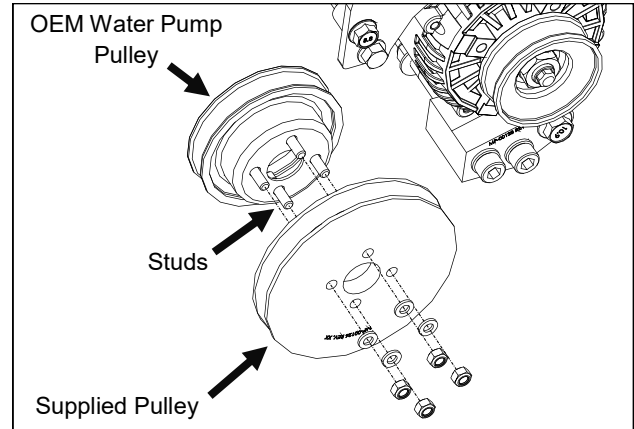

Fig. 2.6 Water Pump Pulley

STEP 3: (COMPRESSOR & BELTS)

- 3.1 Install compressor bracket from below, rotating top forward of differential unit until it is in place. See figure 3.1.

Note: The short M10 bolt is used to fasten compressor bracket to the rear of the engine. Place lock washer against bolt head then flat washer. Torque the (2) M10 bolts to 30 ft lbs. and the M8 bolt to 20 ft lbs.

Tools Required:

8mm Allen socket
6mm Allen socket

Hardware:

M10x1.5 x 35mm socket head bolt
M10x1.5 x 65mm socket head bolt
M10 x 20mm flat washer
M10 x 18mm lock washer
M8x1.25 x 70mm socket head bolt
M8 x 16mm flat washer
M8 x 14.8mm lock washer

Qty:

1
1
2
2
1
1
1

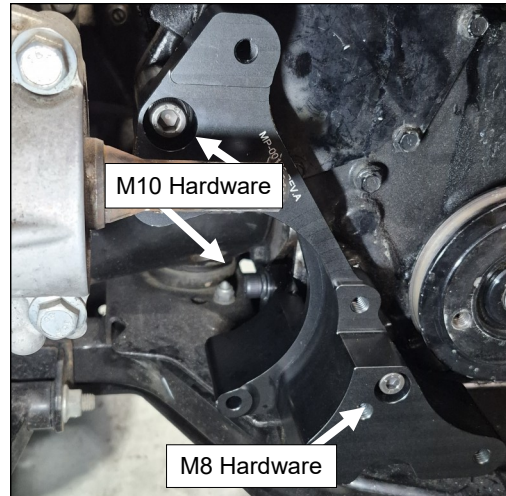

Fig. 3.1 Compressor Bracket Orientation

- 3.2 Per fig. 3.2, orient compressor onto the previously installed compressor bracket and secure. *Note: Short bolt and nut belong in upper compressor ear. Place flat washers under bolt heads. Torque fasteners to 20 ft lbs.*

Tools Required:

13mm Wrench and sockets

M8x1.25 x 110mm hex head bolt
M8x1.25 x 40mm hex head bolt
M8x1.25 flange lock nut
M8 x 16mm flat washer

1
1
2
2

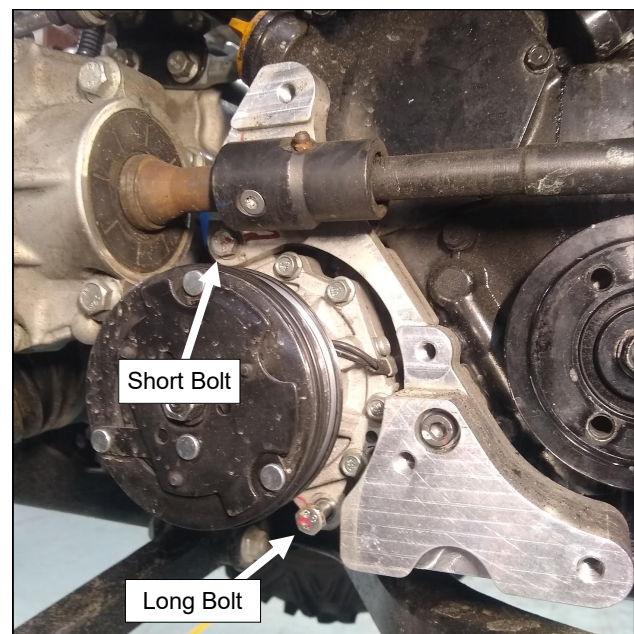

Fig. 3.2 Compressor Orientation

A/C INSTALLATION

STEP 3: (COMPRESSOR & BELTS)

- 3.3 Install water pump belt (AX28) onto the *OEM water pump pulley* and crankshaft pulley. See fig. 3.3.
- 3.4 Install water pump belt tensioner. Tension belt and **torque to 30 ft lbs.**
Caution: Apply grease or an anti-seize compound on fastener threads to prevent galling aluminum.

Tools Required:
9/16" Socket
3/8" Drive ratchet

Hardware:
3/8-16 x 1-1/4" flange head bolt

Qty:
2

- 3.5 Install the supplied crank shaft pulley and **torque to 30 ft lbs.** See Figures 3.6 & 3.7.

Tools Required:
15mm socket

Hardware:
M10x1.5 x 70mm flange head bolt

Qty:
3

- 3.6 Per fig. 3.6, install compressor belt (AX27) and tensioner. Tension belt and **torque to 30 ft lbs.**
Caution: Apply grease or an anti-seize compound on fastener threads to prevent galling aluminum.

Tools Required:
9/16" Socket
3/8" Drive ratchet

Hardware:
3/8-16 x 1" flange head bolt

Qty:
2

- 3.7 Per fig. 3.7, install alternator belt (AX23). Tension and tighten fasteners. Lower alternator fasteners **torque to 30 ft lbs.** Upper alternator adjustment bolt **torque to 20 ft lbs.**

Tools Required:
13mm Socket or wrench
15mm Socket and wrench

- 3.8 Install the supplied debris shroud assembly using the hardware removed during step 1.13.

Tools Required:
T40 Torx

- 3.9 Reinstall lower ROPS, seat back and their respective fasteners. **Torque to 150 ft lbs.**

Tools Required:
18mm Socket and wrench

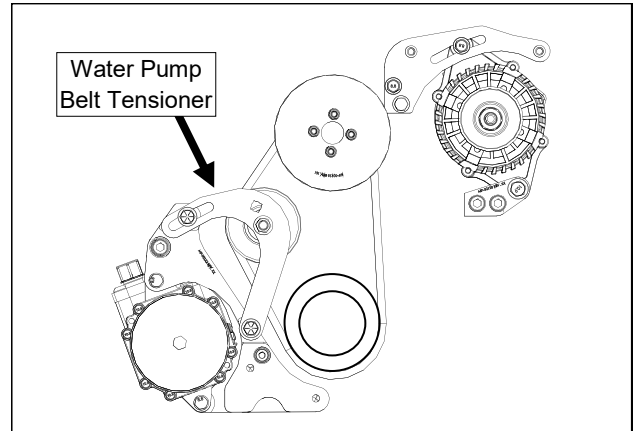

Fig. 3.4 Water Pump Belt and Tensioner

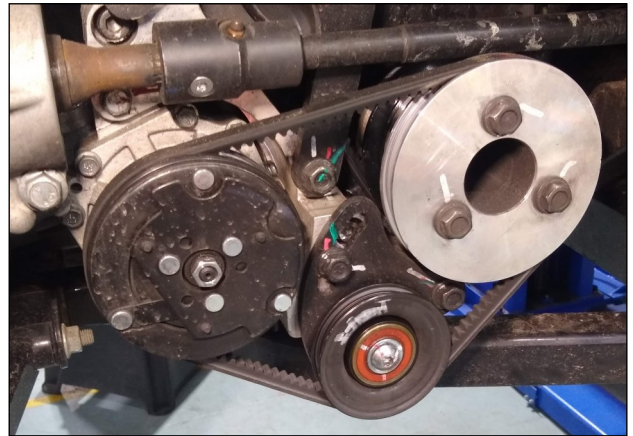

Fig. 3.6 Compressor Belt and Crank Pulley

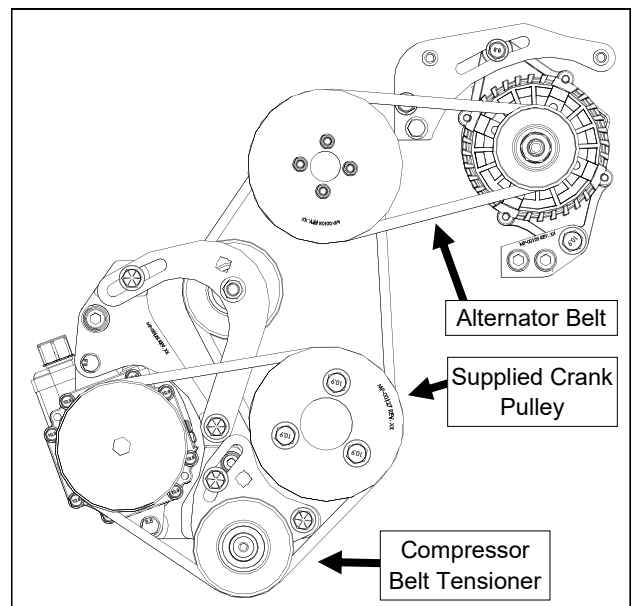

Fig. 3.7 Alternator Belt

IF NOT ALREADY DONE, INSTALL THE CAB AT THIS TIME - BEFORE PROCEEDING TO THE NEXT STEP

A/C INSTALLATION

STEP 4: (ROOF KIT)

- 4.1 Loosely install the left roof bracket to the ROPS. See fig. 4.1.

Tools Required:

9/16" Wrench
9/16" Socket

Hardware:

3/8-16 x 1" flange head bolts	Qty: 2
3/8-16 flange lock nuts	2

- 4.2 Repeat step 4.1 on the right side.

- 4.3 With assistance, position rear roof on cab. Loosely install hardware through the top of the rear panel. Washers under bolt heads. See fig. 4.3.

Tools Required:

1/2" Wrench
1/2" Socket

Hardware:

5/16-18 x 3/4" flange head bolts	Qty: 5
5/16 x .69" OD nylon washers	5
5/16-18 flange lock nuts	5

- 4.4 Per fig. 4.4, position the rear roof stiffener between the ROPS and rear header of the cabin.
Note: The outer slots in roof and stiffener should line up with holes in header.

- 4.5 With assistance, lift the A/C roof unit up and over the vehicle, feeding the hoses and wires down into the cabin area as it is lowered.

Caution: Ensure wires and hoses do not get pinched!

- 4.6 Per fig. 4.6, remove and set aside the (17) flange head bolts, steel and rubber fender washers from the cover of the A/C unit.

Tools Required:

3/8" Socket

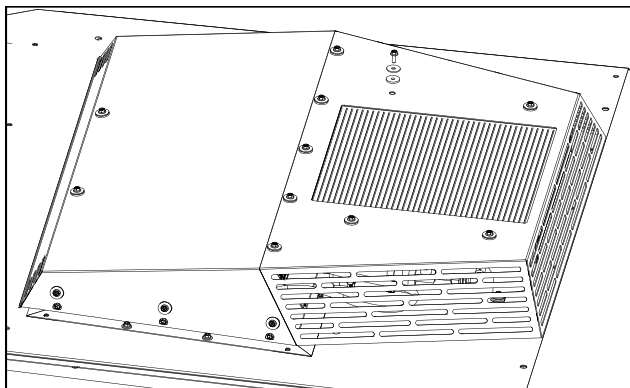

Fig. 4.6 A/C Cover Fasteners



Fig. 4.1 Left Roof Bracket

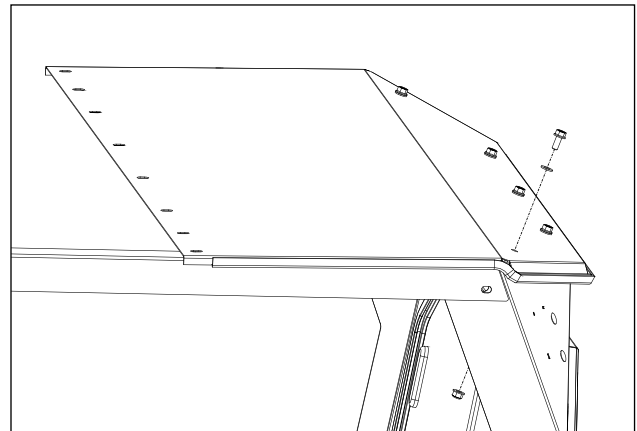

Fig. 4.3 Rear Roof Fasteners

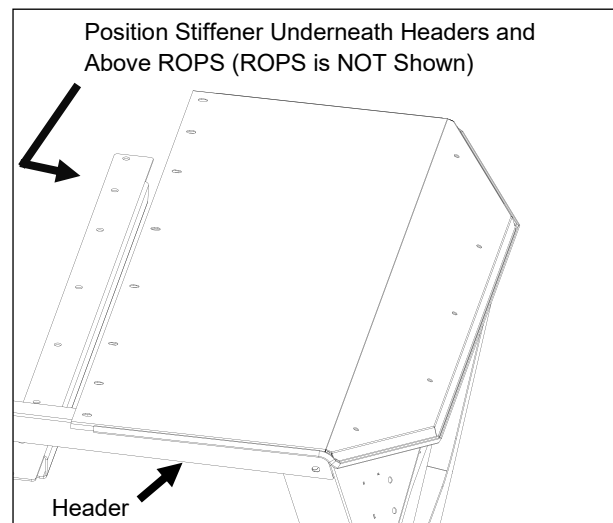

Fig. 4.4 Rear Roof Stiffener

A/C INSTALLATION

STEP 4: (ROOF KIT)

- 4.7 Per fig. 4.7, loosely install the (6) bolts, steel fender washers and rubber fender washers. *Note: Steel washers against bolt head and rubber washers against roof.*

Tools Required:

1/2" Wrench
1/2" Socket

Hardware:

	<u>Qty:</u>	<u>Location</u>
5/16-18 x 1" flange head bolts	2	Center
5/16-18 x 2-3/4" flange head bolts	2	Front
5/16-18 x 3" flange head bolts	2	Rear
5/16 x 1.25" OD steel washers	6	
5/16 x 1.25" OD rubber washers	6	
5/16-18 flange lock nuts	6	

- 4.8 Per fig. 4.8, loosely fasten the remainder of roof fasteners. Washers under bolt heads.

Tools Required:

1/2" Wrench
1/2" Socket

Hardware:

	<u>Qty:</u>
5/16-18 x 3/4" flange head bolts	10
5/16 x .69" OD nylon washers	10
5/16-18 flange lock nuts	10

- 4.9 Per fig. 4.9, install the (6) bolts, nylon washers and lock nuts securing the A/C unit to cabin and vehicle. Washers under bolt heads.

Tools Required:

7/16" Wrench
3/8" Socket

Hardware:

	<u>Qty:</u>	<u>Location</u>
1/4-20 x 3/4" flange head bolts	4	Rear
1/4-20 x 1" flange head bolts	2	Front
1/4 x 3/4" OD nylon washers	6	
1/4-20 flange lock nuts	6	

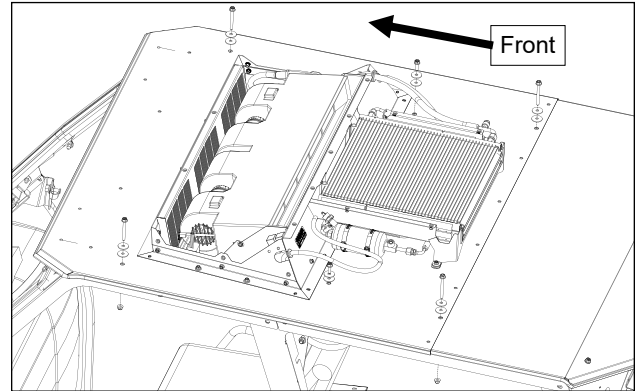

Fig. 4.7 Roof Fasteners

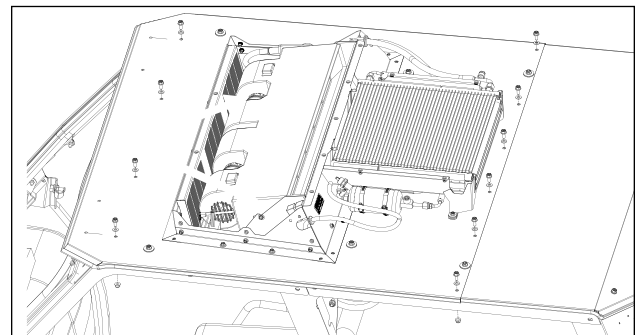

Fig. 4.8 Remaining Roof Fasteners

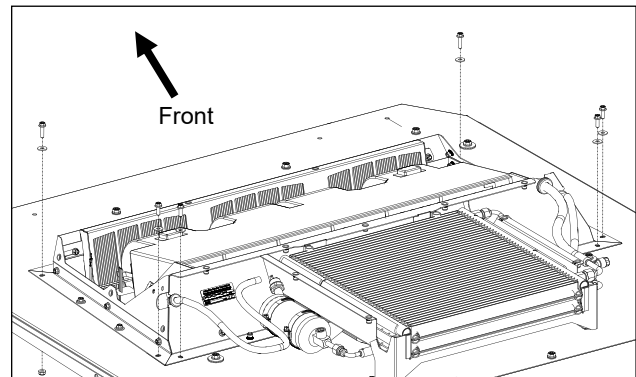

Fig. 4.9 A/C Unit to Cabin/Vehicle Fasteners

STEP 5: (WIRE HARNESS)

- 5.1 Per fig. 5.1, remove the access panel found on the debris shroud previously installed during step 3.8. Set aside panel and hardware.

Tools Required:

3/8" Socket

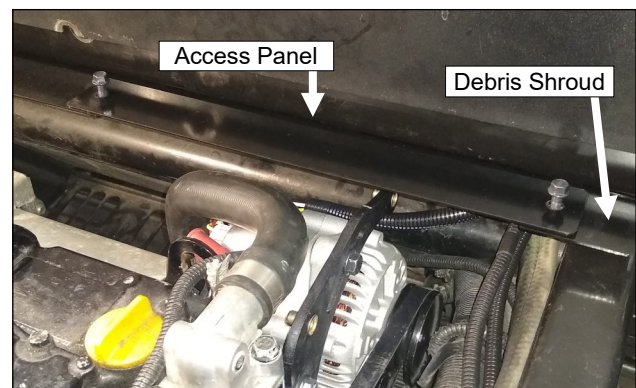

Fig. 5.1 Debris Guard Access Panel

A/C INSTALLATION

STEP 5: (WIRE HARNESS)

- 5.2 Route wire harness down the left side ROPS to the rear of the upper seatbelt attachment point. Continue down to the front of ROPS along the front side of vehicle crossmember. Feed harness through the hole in between the front seats down and rearward to battery compartment. See figures 5.2a and b.
- 5.3 Using the supplied controller as a template, mark and drill the right side of the rear storage compartment (by the battery). *Note: Mark and drill inside of compartment mount to outside as shown in figure 5.3.*

Tools Required:

- Drill
- 3/16" bit

- 5.4 Secure the supplied controller to the outside face of the rear storage compartment. See fig. 5.3.

Tools Required:

- Phillips head screw driver
- 11/32" wrench

Hardware:

#8-32 x 5/8" pan head screw	<u>Qty:</u> 2
#8-32 lock nuts	2

- 5.5 Connect the supplied alternator adapter harness to the back of the alternator and the mating connector on the vehicle harness. Connect the other end to the previously installed controller. See figures 5.5a and b.

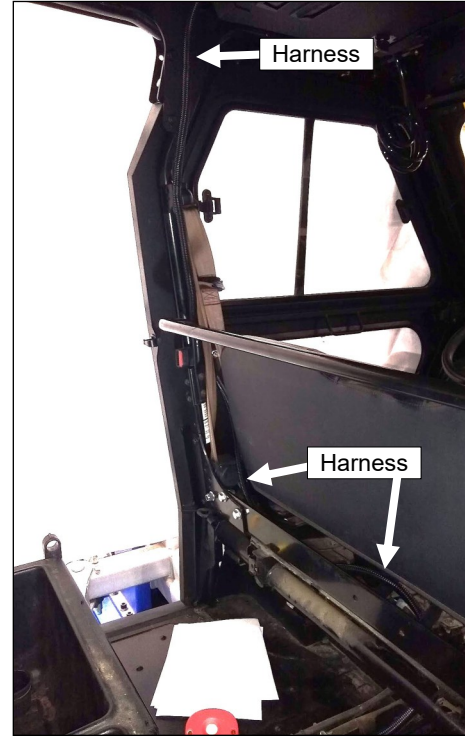

Fig. 5.2a Harness Routing

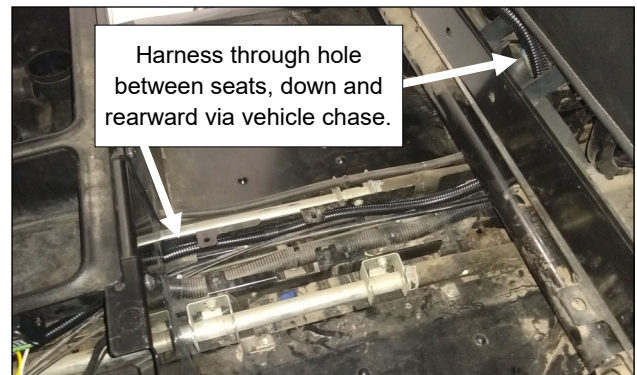

Fig. 5.2b Harness Routing



Fig. 5.5a Adaptor Harness (Alt. and Vehicle Harness)



Fig. 5.5b Adaptor Harness (Controller Connections)



Fig. 5.3 Controller Mounting

A/C INSTALLATION

STEP 5: (WIRE HARNESS)

- 5.6 Per fig. 5.6, connect the supplied ignition jumper wire harness to the vehicle's switched ignition power source located under the passenger's side seat as shown.
- 5.7 Per fig. 5.7, route the end of the supplied ignition jumper harness containing the female bullet terminal to the battery compartment via the vehicle's center chase. Connect to the male bullet found on the yellow wire coming from the A/C unit.
- 5.8 Per fig. 5.8, connect the supplied compressor adaptor harness to the compressor and A/C harness. Route the end with the ring terminal to the vehicle's battery compartment.

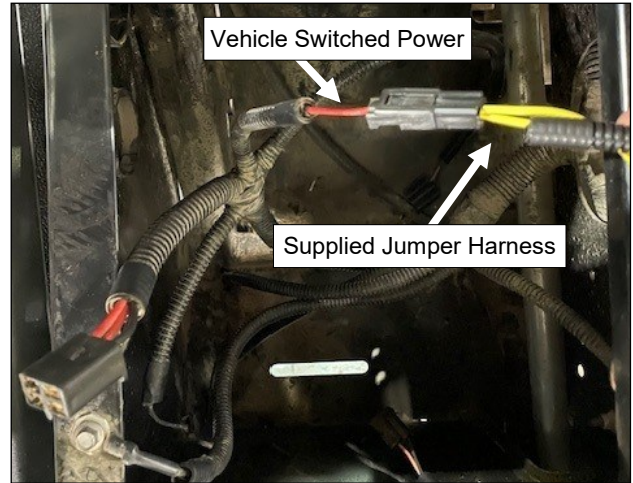

Fig. 5.6 Ignition Jumper - Vehicle Power Connection



Fig. 5.7 Ignition Jumper - A/C Unit Connection

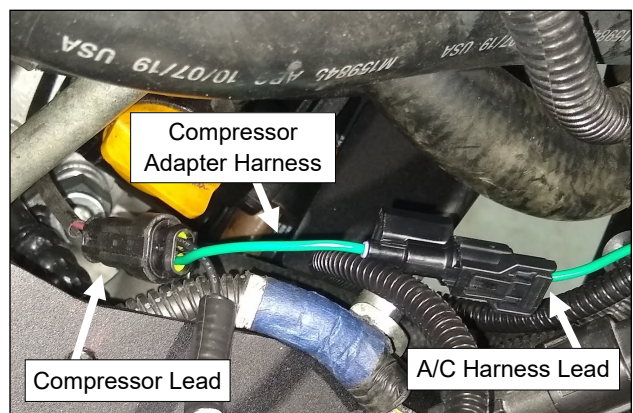

Fig. 5.8 Compressor Adaptor Harness

A/C INSTALLATION

STEP 6: (A/C REFRIGERANT HOSES)

- 6.1 Route A/C hoses as shown. See Figures 6.1a, b, and c.
- 6.2 Install the provided pre-cut 7.25" long piece of Trim-Lok to sheet metal edge to protect hoses. See Figure 6.1b.
- 6.3 Install provided P-clamp around A/C hoses securing to vehicle frame. See Figure 6.1b.
Note: Bolt should pass through clamp, washer, frame and then lock nut.

Hardware:	Qty:
1/4-20 x 2-3/4" hex head bolts	1
1-3/4" P-clamp	1
1/4" x 1" OD steel washer	1
1/4-20 flange lock nut	1

- 6.4 Install the larger #10 hose to the compressor. See fig. 6.4.

Tools Required:
27mm or 1-1/6" Crows foot and extension

- 6.5 Install the smaller #8 hose to the compressor. See fig. 6.4.

Tools Required:
22mm or 7/8" Crows foot and extension

- 6.6 Using provided wire ties, secure A/C refrigerant hoses away from heat sources and all moving parts. See figures 6.1a, b, and c.

Hardware:	Qty:
Wire ties (11" long)	5

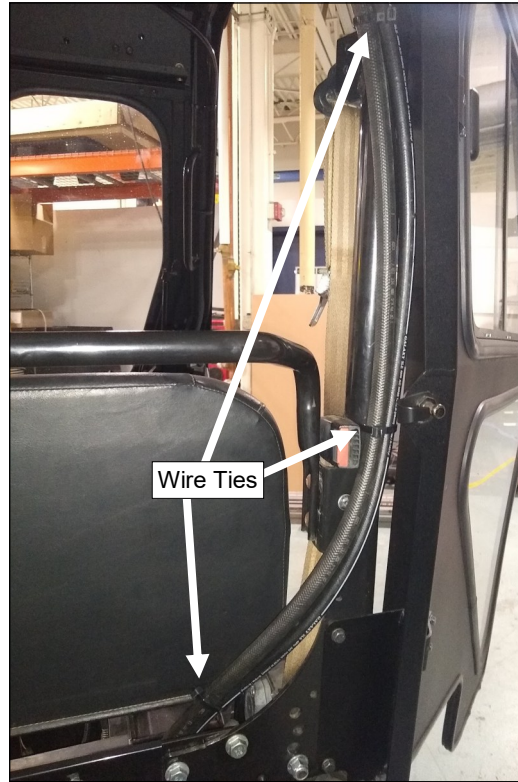

Fig. 6.1a Hose Routing

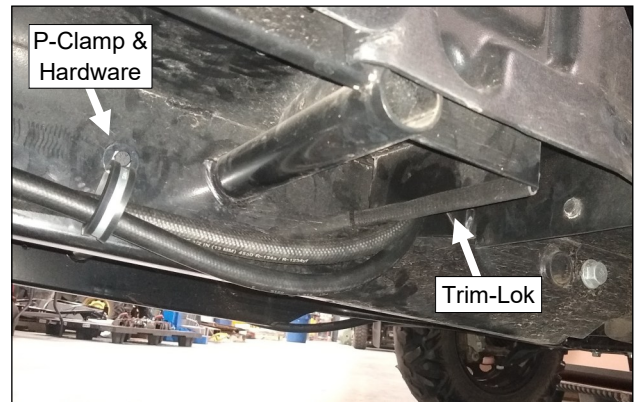

Fig. 6.1b Hose Routing

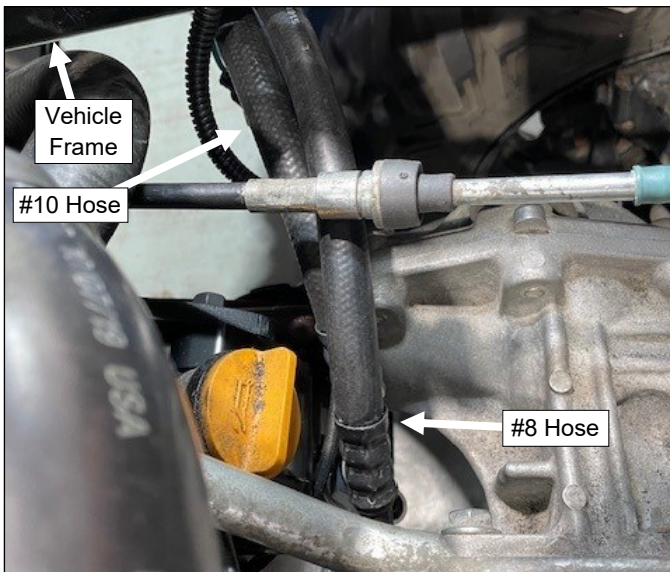

Fig. 6.4 Compressor Hose Connections

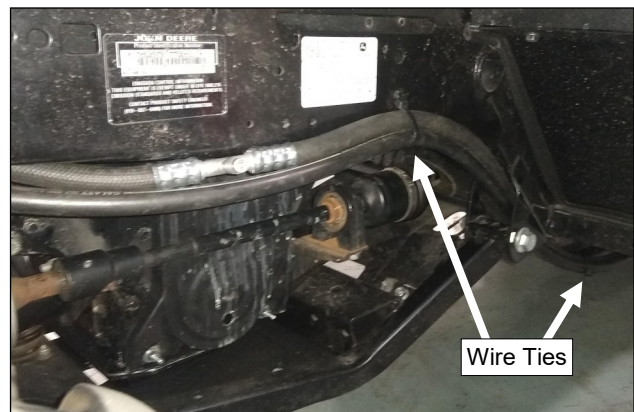

Fig. 6.1c Hose Routing

A/C INSTALLATION

STEP 7: (CONDENSATION DRAIN HOSES)

- 7.1 Route A/C condensation hoses and install zip ties as shown. See figures 7.1a, b, and c. Run left side hoses in the same manner down and along the left side ROPS tube.

*Note: Ensure hoses are pitched downhill to promote drainage. Take care when securing with wire ties. **DO NOT** collapse or pinch off tubing!*



Fig. 7.1a Drain Hose Routing



Fig. 7.1c Drain Hose Routing



Fig. 7.1b Drain Hose Routing

A/C INSTALLATION

STEP 8: (TRANSMISSION & THROTTLE CABLE BRACKETS - DRIVESHAFT)

- 8.1 Per fig. 8.1, install the supplied transmission cable bracket using the hardware removed in step 1.17 and **torque to 34 ft lbs.** Reinstall the retaining clip removed in step 1.15.

Note: Route the vehicle's harness shown in the image so that it can be secured to underside of bracket.

Tools Required:

15mm Socket
Pliers

- 8.2 Per fig. 8.2, install the supplied throttle cable bracket and **torque to 20 ft lbs.** Reinstall the C-clip removed in step 1.14.
Caution: With the help of an assistant, once the throttle cable is rerouted and secure, check accelerator pedal's full range of operation with no signs of resistance or binding. Ensure accelerator pedal consistently and unobstructively returns fully.

Tools Required:

1/2" Socket
Pliers

Hardware:

5/16-18 x 3/4" flange head bolts

Qty:
2

- 8.3 Reinstall the rear driveshaft by reversing step 1.20.

STEP 9: (SHROUDING)

- 9.1 Install lower shroud. **Note: Apply thread sealer and torque M6 bolt to 6 ft lbs. and torque 3/8" bolt to 30 ft lbs.** See figures 9.1a and b.
Caution: Apply grease or an anti-seize compound on the lower shroud 3/8-16 fastener threads to prevent galling.

Tools Required:

10mm Socket and extension
9/16" Socket

Hardware:

M6x1 x 70mm hex head bolt
M6 x 12mm flat washer
.50" OD x .24" ID x .35" lg. Alum. spacer
3/8-16 x 1" flange head bolt

Qty:
1
1
1
1

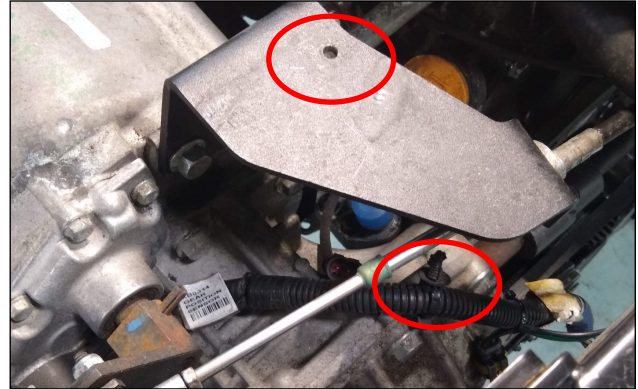

Fig. 8.1 Supplied Transmission Cable Bracket

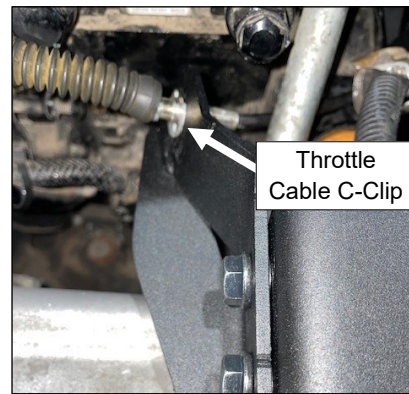

Fig. 8.2 Throttle Cable Bracket



Fig. 9.1a Lower Shroud (Front Fastener)



Fig. 9.1b Lower Shroud (Underside of Vehicle)

A/C INSTALLATION

STEP 9: (SHROUDING)

- 9.2 Per fig. 9.2, install alternator shroud and **torque to 11 ft lbs.**

Tools Required:

3/8" Socket & extension

Hardware:

1/4-20 x 3/4" flange head bolt

Qty:
2

- 9.3 Per fig. 9.3, install water pump shroud using supplied fasteners listed below. Use metric bolt and washer to secure the rearmost tab found on shroud.

Note: Apply thread sealer and Torque metric bolt to 6 ft lbs.. Torque 1/4-20 bolts to 11 ft lbs.

Tools Required:

3/8" Socket

10mm Socket

Hardware:

M6X1.0 x 45mm Hex head bolt

M6 x 12mm flat washer

1/4-20 x 3/4" flange head bolt

Qty:

1

1

3

- 9.4 Per fig. 9.4, reinstall J-hook to support coolant hoses and harnesses. (removed during step 1.21).

Tools Required:

3/8" Socket

Hardware:

1/4-20 x 1" flange head bolt

1/4" x 5/8" flat washer

Qty:

1

1

- 9.5 Reinstall air intake hose to engine and tighten hose clamp.

Tools Required:

5/16" Nut driver or flat blade screw driver

- 9.6 Reinstall the debris shroud access panel which was temporarily removed during step 5.1.

Tools Required:

3/8" socket

STEP 10: (CONNECT WIRING)

- 10.1 Connect the (2) Orange fused leads found on the A/C unit's harness to positive battery terminal. Reconnect positive terminal to battery.
- 10.2 Connect (3) wires to the negative battery terminal; One ring terminal found on the A/C unit's harness, one ring terminal for the compressor adaptor harness, and one ring terminal found on the Tach. controller. Reconnect positive terminal to battery.

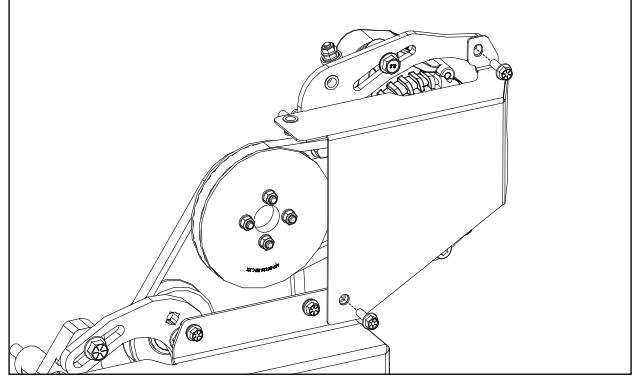

Fig. 9.2 Alternator Shroud

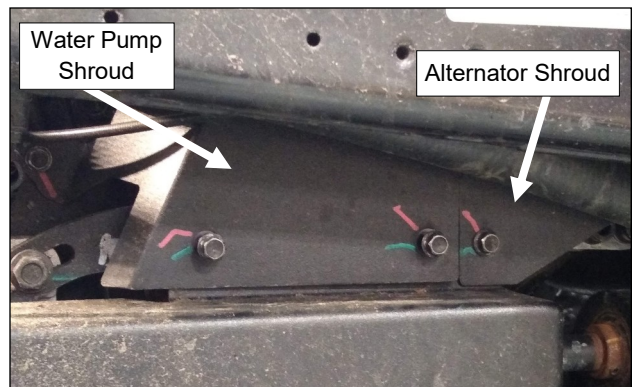

Fig. 9.3 Water Pump Shroud

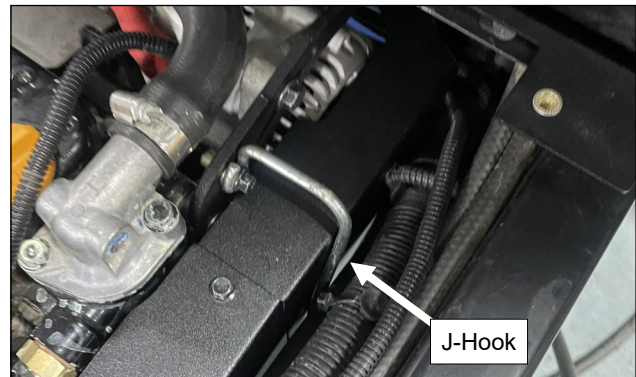

Fig. 9.4 J-Hook

A/C INSTALLATION

STEP 11: (CHARGE A/C)

- 11.1 Per fig. 11.1, connect red high side hose from refrigerant machine to the fitting on the roof at the condenser.
- 11.2 Per fig. 11.2, connect blue low side refrigerant hose to the fitting along the passenger's side frame rail under the bed.
- 11.3 Pull a vacuum for 20-30 minutes.
- 11.4 Complete a leak test if refrigerant machine is capable.
- 11.5 Charge unit with 3.0 lbs. of R134a into high side. Unit comes pre-filled with oil and dye.
- 11.6 Turn unit on when prompted and check to ensure cold air is flowing. LED light should illuminate to indicate compressor is on.
- 11.7 Remove hoses when prompted.
- 11.8 Re-install A/C cover using the (17) fasteners removed in step 4.6.

Tools Required:
3/8" Socket

- 11.9 Double check all lines to ensure they are not rubbing on any sharp edges.

STEP 12: (SET IDLE)

- 12.1 Start engine and turn on A/C and headlights. Referencing the vehicle's *OEM service manual*, set idle speed to 1,130 RPM using dashboard tachometer.

STEP 13: (REINSTALL CARGO BED)

- 13.1 Referencing the *OEM service manual*, reinstall the cargo bed to the vehicle frame which was removed in step 1.9.

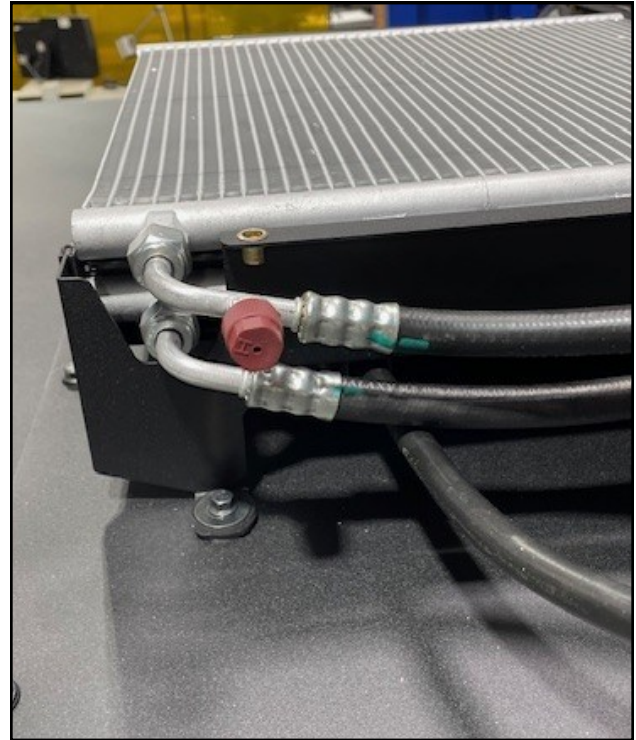

Fig. 11.1 Connect Hoses



Fig. 11.2 Connect Hoses

CARE AND MAINTENANCE

- Check the alternator belt tension after the first 5 hours of use. Re-check tension every 50 hours thereafter, or annually, whichever comes first.
- Check and tighten hardware after 10 hours of operation. Periodically inspect and tighten hardware for the remainder of the unit's life. Check for any wearing or chaffing on hoses or wiring and correct as necessary.
- This product is designed with the use of R134a as a refrigerant. Never substitute other refrigerants, use of any other refrigerant will void warranty.
- Charge unit with 3.0 lbs. of R134a refrigerant.
- Apply vacuum for a minimum of 30 minutes prior to charging the air conditioner with R134a.
- Do not vent refrigerant to the atmosphere. If the unit has to be discharged for any reason, recover the refrigerant in compliance with federal, state, and local laws.
- Refrigerant Oil - use only **ZEROL 300 (ISO 68)** to replenish any oil lost during refrigerant recovery.
- Replace the drier receiver (9SV-9AC-00003) when replacing a compressor (8SV-9AC-00069).

TROUBLESHOOTING

- Check all electrical connections to ensure that proper connections are made and terminals are all tight.
- Check Battery Condition:
Resting/No Load Voltage should be 12.35V or greater.
Terminals should be clean and tight.
- Check all fuses:
30 amp fuses located at battery.
- Check both relays. Located inside the air conditioner.
- Check alternator output. The output should be 12-14 volts DC.
- Check the tension of the V-belt and flat belt.

A/C KIT SERVICE PARTS

WIRE HARNESS
P/N: 9SV-WH-00162



REF. LINE, #10 EVAP TO COMPRESSOR
P/N: 8SV-305-00039

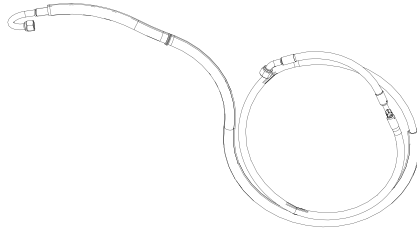

REF. LINE, #8 COMP TO CONDENSER
P/N: 8SV-305-00040

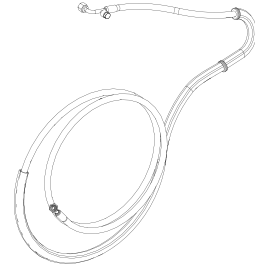

VINYL INTERIOR HOSE WRAP
P/N: 8SV-112-00097

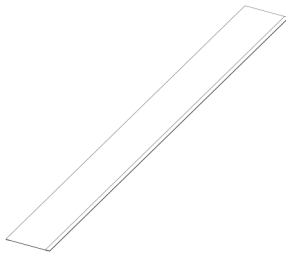

EVAPORATOR, 12V, 3 SPD
P/N: 8SV-9AC-00054-A

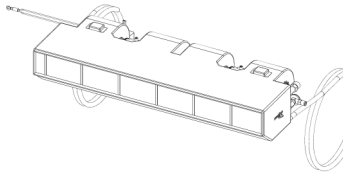

REF. LINE, #6, DRIER TO EVAPORATOR
P/N: 8SV-305-00031



REF. LINE, #6, CONDENSER TO DRYER
P/N: 8SV-305-00032



REF. LINE, #8, CONDENSER TO CONDENSER
P/N: 8SV-305-00033



AIR FILTER PANEL, SLIDING
P/N: 8SV-SM-02907-TB

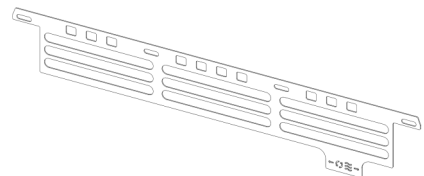

COMPRESSOR
P/N: 8SV-9AC-00069

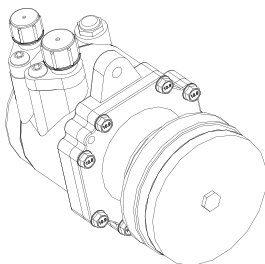

A/C COVER ASSY
P/N: 8SV-303-00015-TB

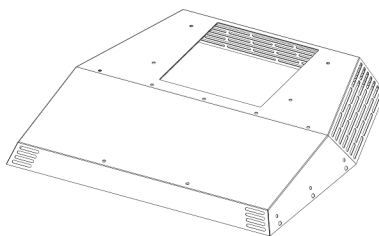

LOWER ALTERNATOR BRACKET
P/N: 9SV-MP-00128

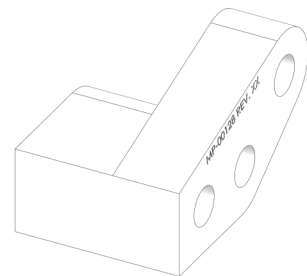

A/C KIT SERVICE PARTS

UPPER ALTERNATOR BRACKET
P/N: 8SV-110-00149

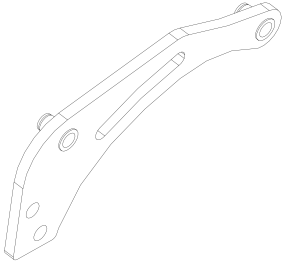

WATER PUMP TO ALTERNATOR
PULLEY
P/N: 9SV-MP-00126

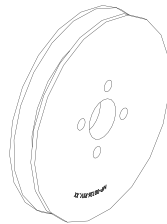

CRANK TO COMPRESSOR PULLEY
P/N: 9SV-MP-00127

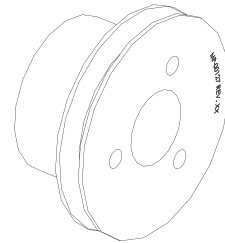

COMPRESSOR MOUNT
P/N: 9SV-MP-00122

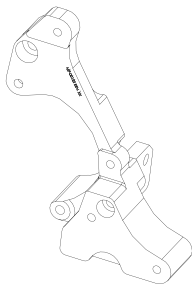

WATER PUMP BELT TENSIONER
P/N: 8SV-113-00429

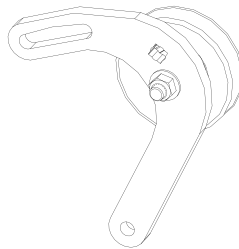

COMPRESSOR BELT TENSIONER
P/N: 8SV-113-00430

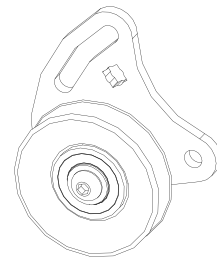

ALTERNATOR SHROUD
P/N: 8SV-113-00482

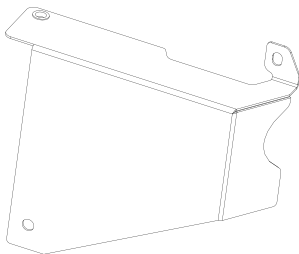

WATER PUMP SHROUD
P/N: 8SV-SM-03232

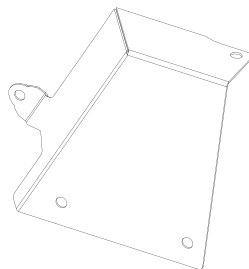

LOWER SHROUD
P/N: 8SV-113-00466

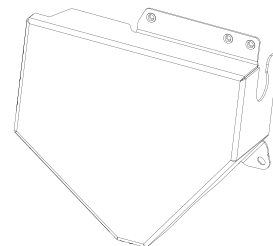

ALTERNATOR V-BELT
P/N: 9SV-9BLT-22



COMPRESSOR V-BELT
P/N: 9SV-9BLT-23



WATER PUMP V-BELT
P/N: 9SV-9BLT-24



A/C KIT SERVICE PARTS

THROTTLE CABLE BRACKET
P/N: 8SV-SM-03264

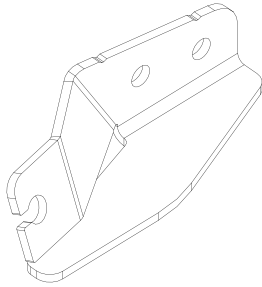

TRANS. LINKAGE BRACKET
P/N: 8SV-110-00150

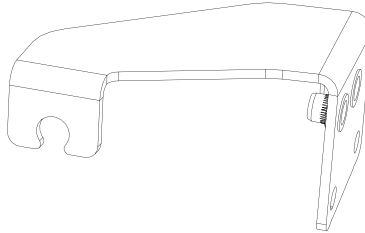

HARNESS, COMPRESSOR ADAPTER
P/N: 9SV-WH-00172

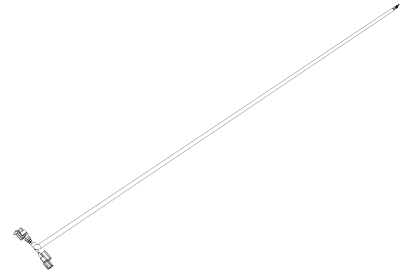

HARNESS, IGNITION JUMPER
P/N: 9SV-WH-00174

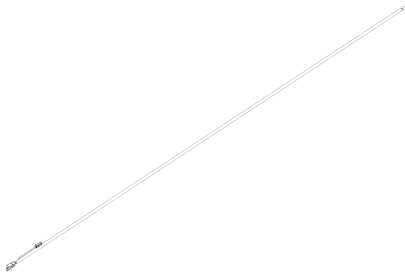

HARNESS, ALT. ADAPTER, TACH. CONTROLLER
P/N: 9SV-WH-00176

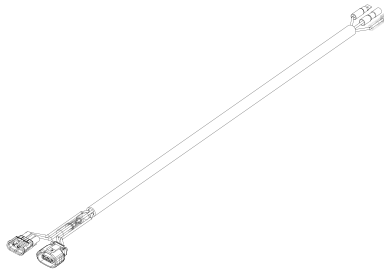

TACH. CONTROLLER
P/N: 8SV-114-00063

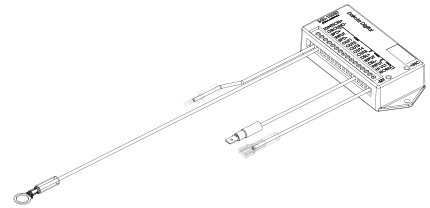

REPLACEMENT LOUVER
P/N: 9SV-9HR-L

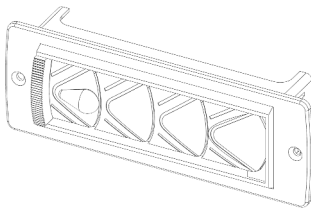

DECAL, A/C CONTROLS
P/N: 9SV-9DL-299

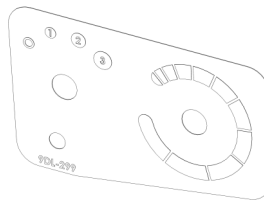

KNOB, 4 WAY ROTARY SWITCH
P/N: 9SV-OHC-27

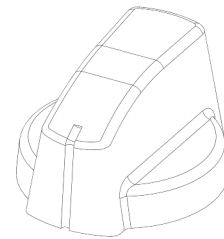

LED COMPRESSOR SIGNAL LIGHT
P/N: 9SV-85-18-0072



OC, RELAY, 12V, 50/30A, SPDT MINI ISO
P/N: 9SV-85-01-0076

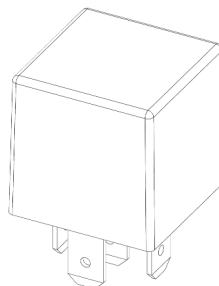

PARALLEL FLOW CONDENSER
P/N: 9SV-9AC-00057

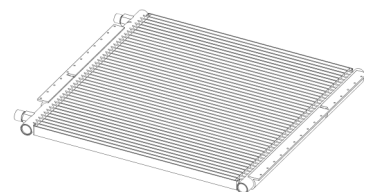

A/C KIT SERVICE PARTS

VIBRATION MOUNT (QTY.: ONE)
P/N: 9SV-9VM02

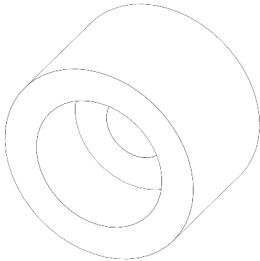

AIR FILTER
P/N: 9SV-9HR-0040

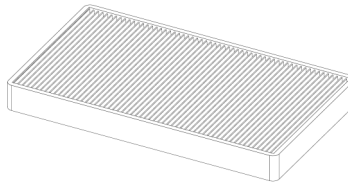

ALTERNATOR
P/N: 8SV-114-00058

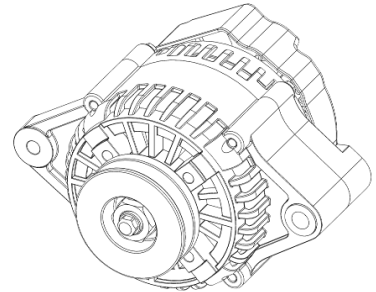

AXIAL FAN, CONDENSER
P/N: 9SV-9AC-00007

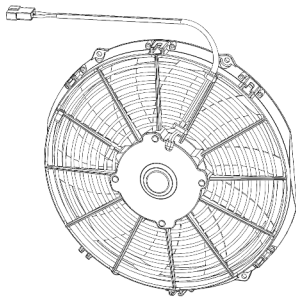

RECEIVER DRIER
P/N: 9SV-9AC-00003

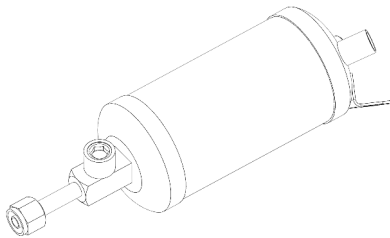

PRESSURE SWITCH
P/N: 9SV-9AC-00005

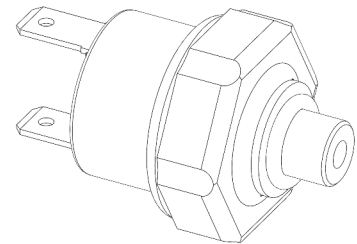

FRONT ROOF AND A/C ASSY
(NO ALT, HW BOX)
P/N: 8SV-ACXUVS4DACUNIT

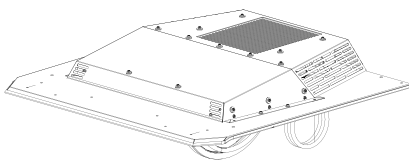

HARDWARE KIT, ACXUVS4D
P/N: 9SV-HWK-00217

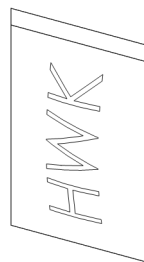

O-RINGS (INCL 1 EA: #6, #8, #10)
P/N: 9SV-9OR-01



REAR ROOF ASSEMBLY
P/N: 8SV-101-00076

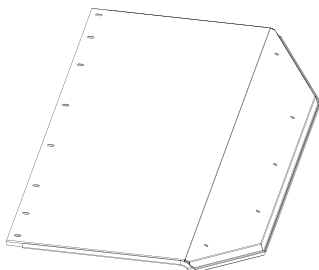

LEFT & RIGHT ROOF MOUNTING
BRACKETS
P/N: 8SV-SM-03323

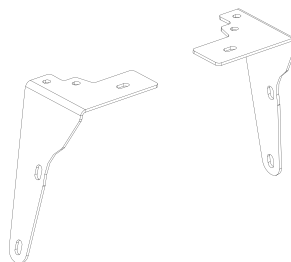

ROOF STIFFENING BRACKET
P/N: 8SV-SM-03610

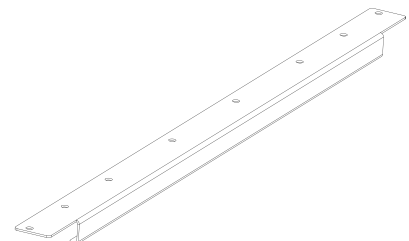

A/C KIT SERVICE PARTS

DEBRIS SHROUD ASSEMBLY
P/N: 8SV-113-00442

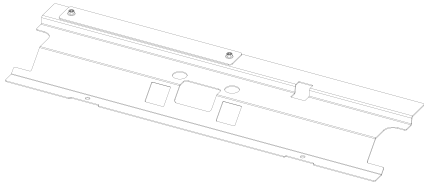

DEBRIS SHROUD ACCESS PANEL
P/N: 8SV-SM-03352

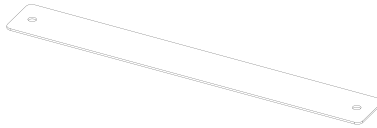

VINYL HOOD SEAL
P/N: 8SV-112-00103



<p>TRIM LOK, STD, 1/16" - 1/8" GRIP</p>	<p>5/8" STD BULB, 1/16" GRIP</p>	<p>ARCH P.S.A.</p>	<p>1" ROUND BULB, 1/16" GRIP</p>	<p>1/2" WEATHERSEAL</p>	<p>5/8" SIDE BULB 1/16" GRIP</p>	<p>1/2" X 9/16"</p>
<p>9SV-PRO1-20</p>	<p>9SV-PRO2-15</p>	<p>9SV-PRO9-10</p>	<p>9SV-PR19-10</p>	<p>9SV-PR20-10</p>	<p>9SV-PR27-5</p>	<p>9SV-PR43-4</p>



BOLT TORQUE

BOLT TORQUE SPECIFICATIONS

GENERAL TORQUE SPECIFICATION TABLE

Use the following torques when special torques are not given. These values apply to fasteners as received from suppliers, dry, or when lubricated with normal engine oil. They do not apply if special graphited or moly disulphide greases or other extreme pressure lubricants are used. This applies to both UNF and UNC threads. Remember to always use grade five or better when replacing bolts.

IMPORTANT: On all PLATED GRADE 8 bolts, reduce torque 15% from listed bolt torque specification.

SAE Grade No.		2				5				8*			
Bolt head identification mark as per grade. NOTE: Manufacturing Marks Will Vary													
		TORQUE		TORQUE		TORQUE		TORQUE		TORQUE		TORQUE	
Bolt Size		Pounds Feet		Newton-Meters		Pounds Feet		Newton-Meters		Pounds Feet		Newton-Meters	
Inches	Millimeters	Min.	Max.	Min.	Max.	Min.	Max.	Min.	Max.	Min.	Max.	Min.	Max.
1/4	6.35	5	6	7	8	9	11	12	15	12	15	16	20
5/16	7.94	10	12	14	16	17	20.5	23	28	24	29	33	39
3/8	9.53	20	23	27	31	35	42	48	57	45	54	61	73
7/16	11.11	30	35	41	47	54	64	73	87	70	84	95	114
1/2	12.70	45	52	61	70	80	96	109	130	110	132	149	179
9/16	14.29	65	75	88	102	110	132	149	179	160	192	217	260
5/8	15.88	95	105	129	142	150	180	203	244	220	264	298	358
3/4	19.05	150	185	203	251	270	324	366	439	380	456	515	618
7/8	22.23	160	200	217	271	400	480	542	651	600	720	814	976
1	25.40	250	300	339	406	580	696	787	944	900	1080	1220	1464
1-1/8	25.58	-	-	-	-	800	880	1085	1193	1280	1440	1736	1953
1-1/4	31.75	-	-	-	-	1120	1240	1519	1681	1820	2000	2468	2712
1-3/8	34.93	-	-	-	-	1460	1680	1980	2278	2380	2720	3227	3688
1-1/2	38.10	-	-	-	-	1940	2200	2631	2983	3160	3560	4285	4827

*Thick Nuts must be used with Grade 8 bolts

METRIC BOLT TORQUE SPECIFICATIONS



Size of Screw	Property Class	Course Thread			Fine Thread		
		Pitch (mm)	Pounds Feet	Newton-Meters	Pitch (mm)	Pounds Feet	Newton-Meters
M6	5.6	1.0	3.6-5.8	4.9-7.9	-	-	-
	8.8		5.8-9.4	7.9-12.7		-	-
	10.9		7.2-10	9.8-13.6		-	-
M8	5.6	1.25	7.2-14	9.8-19	1.0	12-17	16.3-23
	8.8		17-22	23-29.8		19-27	25.7-36.6
	10.9		20-26	27.1-35.2		22-31	29.8-42
M10	5.6	1.5	20-25	27.1-33.9	1.25	20-29	27.1-39.3
	8.8		34-40	46.1-54.2		35-47	47.4-63.7
	10.9		38-46	51.5-62.3		40-52	54.2-70.5
M12	5.6	1.75	28-34	37.9-46.1	1.25	31-41	42-55.6
	8.8		51-59	69.1-79.9		55-68	75.9-92.1
	10.9		57-66	77.2-89.4		62-75	84-101.6
M14	5.6	2.0	49-56	66.4-75.9	1.5	52-64	70.5-86.7
	8.8		81-93	109.8-126		90-106	122-143.6
	10.9		96-109	130.1-147.7		107-124	145-168
M16	5.6	2.0	67-77	90.8-104.3	1.5	69-83	93.6-112.5
	8.8		116-130	157.2-176.2		120-138	162.6-187
	10.9		129-145	174.8-196.5		140-158	189.7-214.1
M18	5.6	2.0	88-100	119.2-136	1.5	100-117	136-158.5
	8.8		150-168	203.3-227.6		177-199	239.8-269.6
	10.9		175-194	237.1-262.9		202-231	273.7-313
M20	5.6	2.5	108-130	146.3-176.2	1.5	132-150	178.9-203.3
	8.8		186-205	252-277.8		206-242	279.1-327.9
	10.9		213-249	288.6-337.4		246-289	333.3-391.6