



A/C Alternator Kit
p/n: 1ACKAFXT1DRK
(fits KAWASAKI MULE PRO-FX 1000 & PRO-FXT 1000)

Must be installed with Curtis Cab:
 Pro-FX: 1KAPFXCA-AC (poly windshield) or 1KAPFXCAS1-AC (glass windshield)
 Pro-FXT: 1KAPFXTCA-AC (poly windshield) or 1KAPFXTCAS1-AC (glass windshield)

Must be installed with Curtis Air Conditioner: 1ACUNIT-TBCOVER

For vehicles with cabs already installed, order Curtis A/C Roof Kit:
 1ACKAPFXDXRFK (for Pro-FX) or 1ACKAPFXTDXTRFK (for Pro-FXT)

CAUTION: Never turn the air conditioner upside down or on its side. Doing so will drain the compressor of its oil and will void the warranty.

Approximate Installation Time *
Experienced Dealer Technician –1 Hour
Average Dealer Technician – 1.5 Hours
Do-It-Yourself – 2 Hours

(*Not including cab & other accessories)

Approximate Product Specifications
Weight: 36 lbs.

The contents of this envelope are the property of the owner. Leave with the owner when installation is complete.

TABLE OF CONTENTS

WARNINGS, TIPS, & REQUIRED TOOLS.....	2
INSTALLATION	3-19
CARE AND MAINTENANCE	19
SERVICE PARTS	20-21
BOLT TORQUE SPECIFICATIONS	22

WARNINGS, TIPS, & REQUIRED TOOLS

Curtis accessories feature an assembly of parts designed for your vehicle which require adjustment and alignment of components to accommodate vehicle variations. For accurate installation, proper operation, and years of satisfaction, please read and understand the installation and owner's manual fully, prior to installing this accessory.

From all of us at Curtis, we thank you for choosing our product.

NOTICE

Curtis Cabs, blades and general accessories add additional weight to the base vehicle. All Curtis accessory weights are listed in product brochures. Deduct the accessory's total weight from the vehicle's rated capacity and never exceed the vehicle's rated capacity including driver and passenger.

California Health and Safety Proposition 65 Warning: This product may contain chemicals known to the state of California to cause cancer and birth defects or other reproductive harm.

GENERAL INFORMATION BEFORE YOU START

HELPFUL HINTS:

- Refer to parts diagram found in the service parts section of this manual to help identify parts during the assembly process.
- To assist with the installation, leave all fasteners loose for later adjustment unless otherwise specified.
- Read and understand all instructions before beginning.
- Use proper personal protective equipment during all phases of installation.
- ALWAYS shut off engine before leaving the operator's seat to perform any portion of the procedures listed in this manual.
- ALWAYS disconnect the ground cable from the battery when working with any electronics components.
- Follow Lock-out / Tag-out procedures to maintain a safe work environment.

TOOLS REQUIRED

- | | |
|---|---|
| <ul style="list-style-type: none"> • Set of metric & standard sockets (1/4" or 3/8" drive) • Set of metric & standard open-end wrenches • Set of metric & standard Allen wrenches • Ratchet and extensions • #2 & #3 Phillips screw driver • Flathead screw driver • Belt tension tester & straight edge | <ul style="list-style-type: none"> • Torque wrench • Drill and 3/16" drill bit • Pop Riveter with 3/16" insert • Snips • Diagonal Cutters • Pliers • Plastic-cutting saw of choice |
|---|---|

CARE AND MAINTENANCE

- Readjust the belts after the initial 8-10 hours of vehicle use.
- Check and tighten hardware after 20 hours of vehicle operation. Periodically inspect and tighten hardware for the remainder of the unit's life.

KIT INSTALLATION

STEP 1: (A/C UNIT PREP)

- 1.1 Before removing the A/C Unit from shipping pallet, remove the cover from the unit (save the hardware for re-use) and then remove a 1-3/8" dome plug on the front or rear side of the A/C Unit based on the vehicle it will be installed on per Fig 1.1. The wire will be routed through this hole.

Tools

3/8" wrench or socket

- 1.2 Install 1-7/8" O.D. Grommet onto the end of the A/C Power Supply Harness shown in Fig. 1.2. Make sure small lip of the grommet is pointed towards the end shown.
- 1.3 Route the A/C Power Supply Harness per fig 1.3.

On Pro-FX: Route harness through the hole and forward to the power solenoid. Snake it below the refrigerant line making sure nothing is protruding too high above the unit that will interfere with A/C Cover installation and install the grommet into the hole.

On Pro-FXT: Determine how vehicle will be used most often. If in a single seat configuration more often, route harness like FX and install A/C unit into the roof oriented like the FX. If it will be used in 2 row configuration, route in next to the compressor as shown for FXT and install the grommet into the hole.

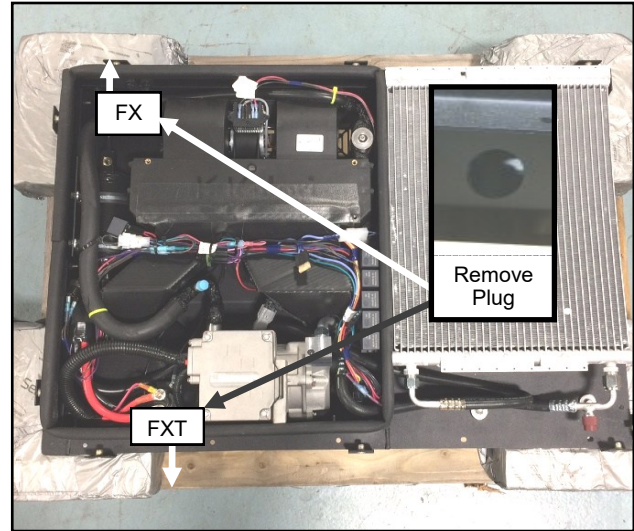

Fig. 1.1 (Remove dome plug from A/C Unit)

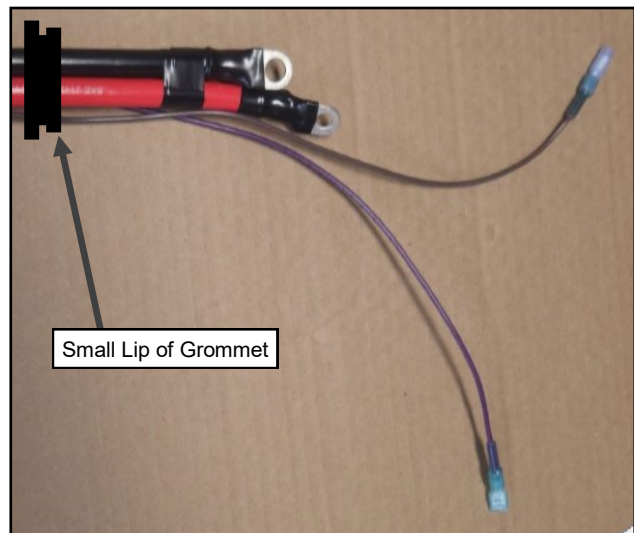

Fig. 1.2 (Install grommet on this end of power harness)

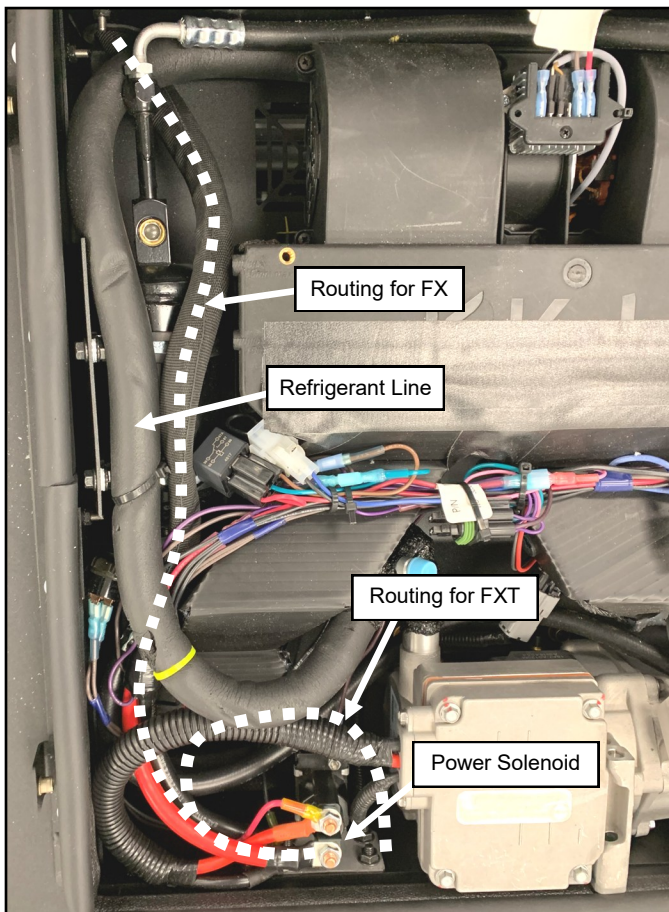

Fig. 1.3 (Route harness inside A/C Unit)

KIT INSTALLATION

STEP 1: (A/C UNIT PREP CONT'D.)

- 1.4 Remove the nut securing the ground wires to the solenoid mounting plate. Next, install the A/C Power Supply Wire Harness' black ground wire onto the bolt, re-install the nut and then tighten as shown in fig. 1.4. Be sure that all original wires remain installed on the ground fastener.

Tools

5/32" Allen Wrench
7/16" wrench or socket

- 1.5 Install the red power wire found on the A/C Power Supply Wire Harness onto the empty post found on top of the solenoid per fig 1.5.

Tools

1/2" wrench or socket

- 1.6 Install Jumper Harness supplied in this kit into the white connector on the A/C Unit's main harness per fig 1.6.

- 1.7 Connect the purple wire on the A/C Power Supply Wire Harness to the purple wire on the A/C Unit harness per fig. 1.7. The brown wire on the A/C power supply wire harness will not be used.

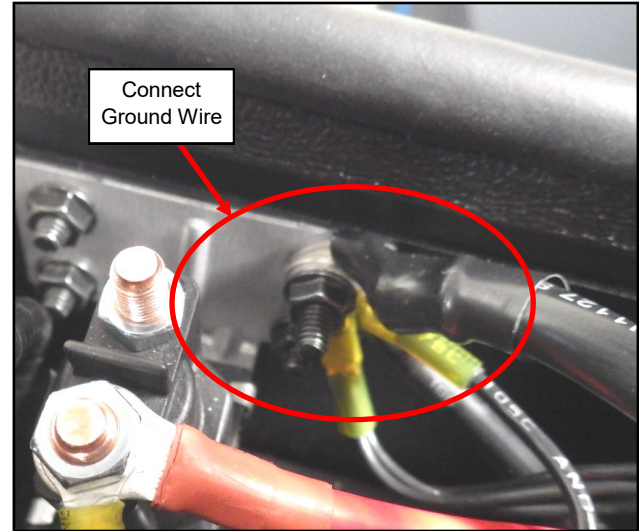

Fig. 1.4 (Connect ground to A/C Unit)

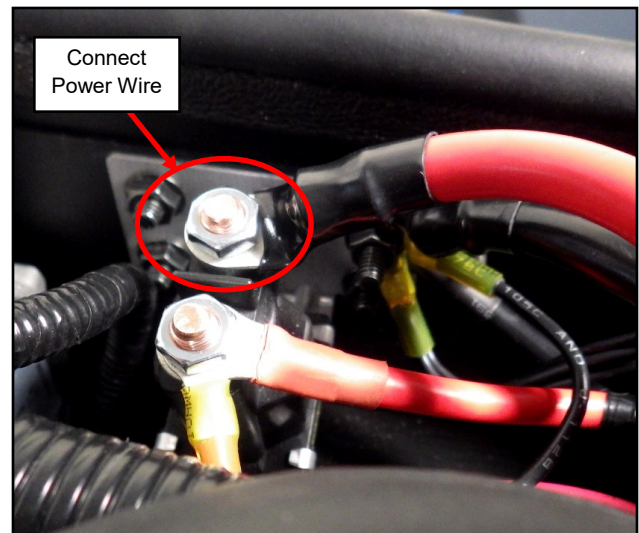

Fig. 1.5 (Connect power wire to A/C Unit)

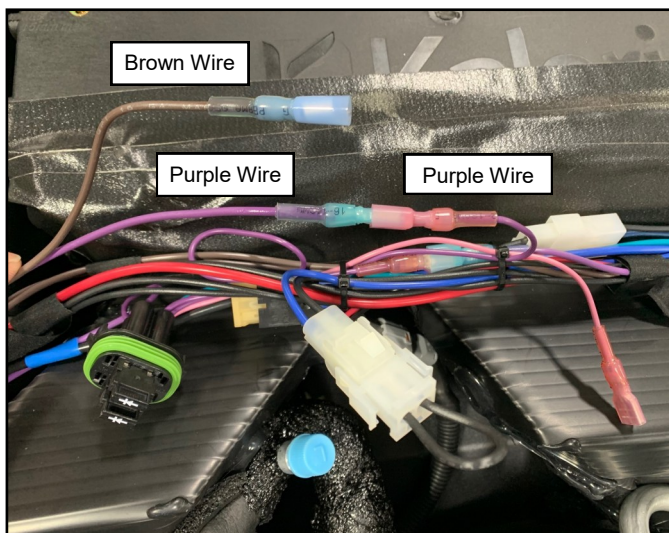

Fig. 1.7 (Connect A/C Power Wire Harness)

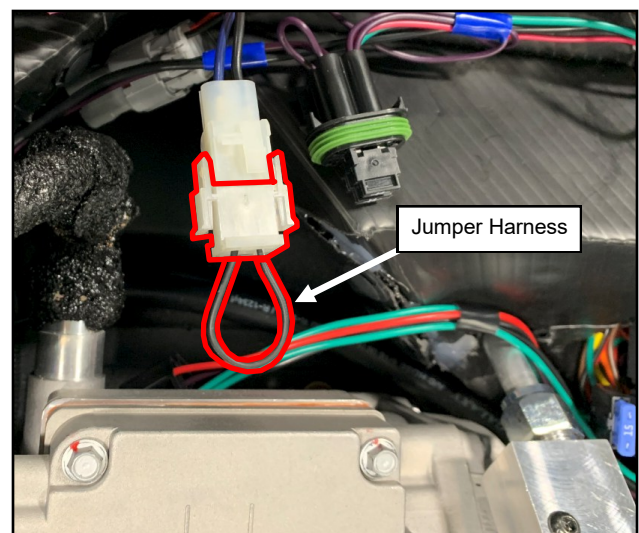

Fig. 1.6 (Install Jumper Harness)

KIT INSTALLATION

STEP 1: (A/C UNIT PREP CONT'D.)

- 1.8 Bundle the wires in the tray formed by the ductwork as shown in fig. 1.8. and use the supplied tie wraps to hold the harnesses together.

Hardware Used

8" Wire Ties

Qty

4

Tools

Diagonal Cutters

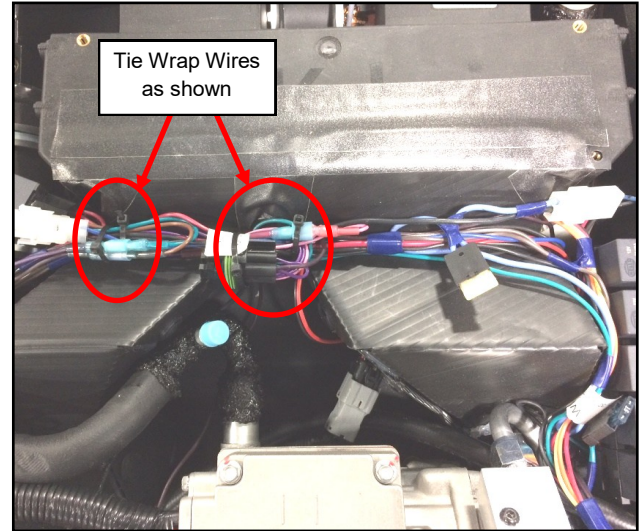

Fig. 1.8 (Tie Wrap Harnesses together)

STEP 2: (VEHICLE PREP)

For Mule PRO-FXT

If installing alternator kit on Mule Pro-FX vehicle, proceed to step 2.4 on the next page.

- 2.1 Disconnect the (2) latches on either side of the vehicle in front of the bed and tilt the back seat bottom forwards per fig 2.1.
- 2.2 Grab handles on the side of the bed and tilt the bed backwards per fig. 2.2.
- 2.3 Disconnect the (2) small latches found on either side of the battery cover and set aside the cover per fig. 2.3.

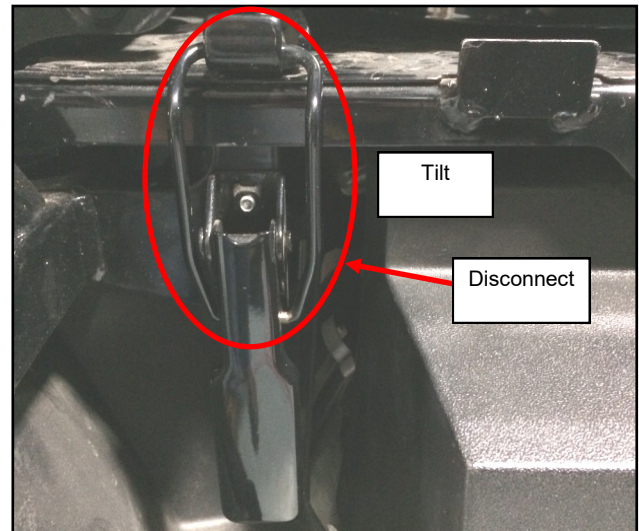

Fig. 2.1 (Tilt Seat Forward, Pro-FXT)

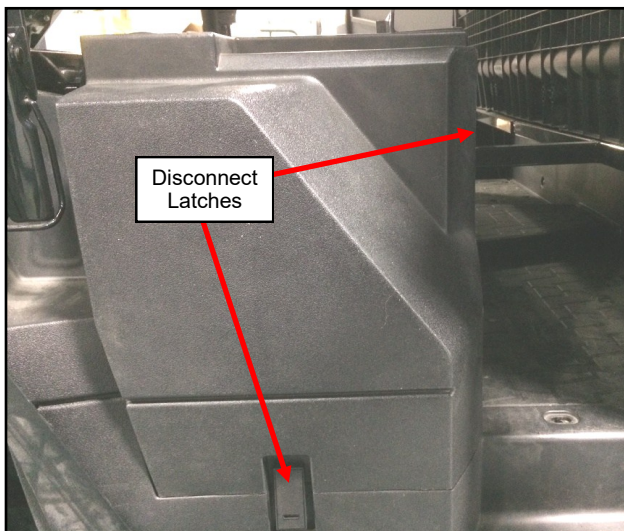

Fig. 2.3 (Remove Battery Cover, Pro-FXT)

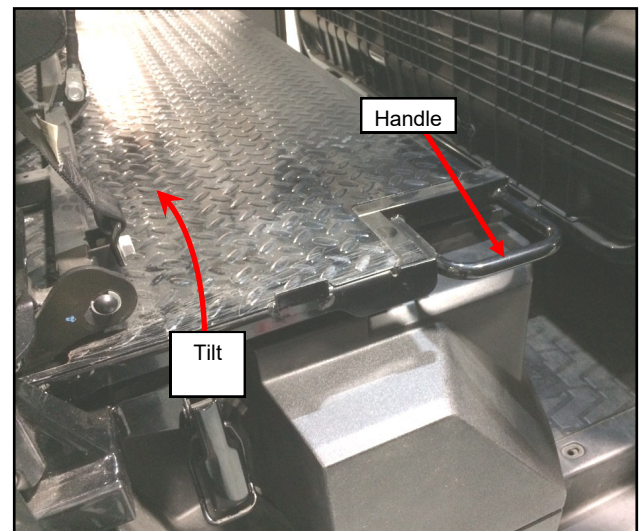

Fig. 2.2 (Tilt Bed, Pro-FXT)

KIT INSTALLATION

STEP 2: (VEHICLE PREP CONT'D.)

For Mule PRO-FX

If installing alternator kit on Mule Pro-FXT vehicle, proceed to step 2.7.

- 2.4 Disconnect the (2) latches on either side of the vehicle in front of the bed and tilt the back seat bottom forwards per fig 2.4.
- 2.5 Disconnect the (2) small latches found on either side of the battery cover and set aside the cover per fig. 2.5.
- 2.6 Remove and set aside seat back cover with its (6) Plastic Rivets & (3) Screws per fig. 2.6.

Tools

Flathead Screwdriver
#3 Phillips Screwdriver

For both Mule PRO-FX & PRO-FXT

- 2.7 Disconnect the ground from the battery as shown on fig. 2.7.

Tools

1/2" Wrench

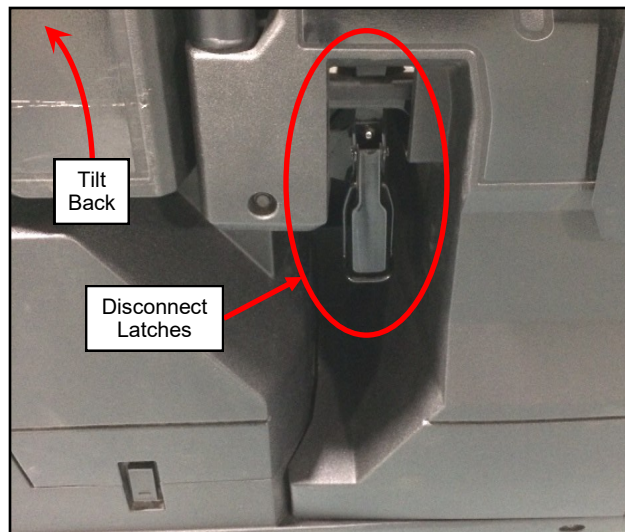

Fig. 2.4 (Tilt Bed, Pro-FX)



Fig. 2.5 (Remove Battery Cover, Pro-FX)

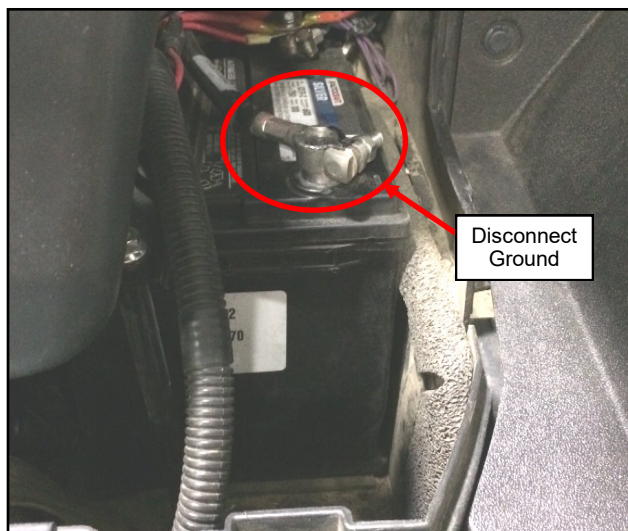

Fig. 2.7 (Disconnect Ground On Battery)

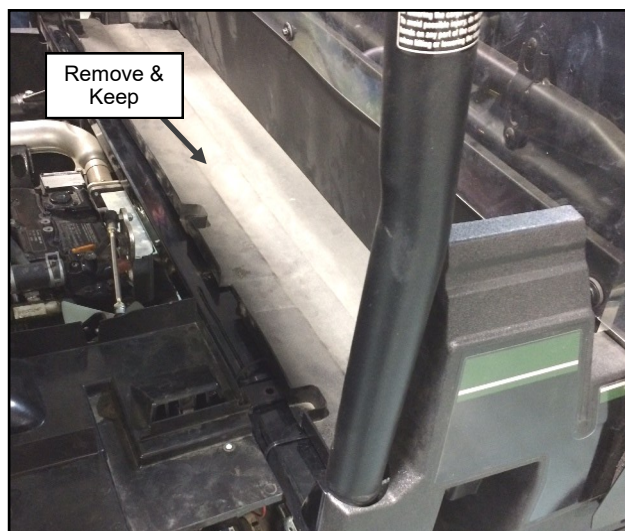

Fig. 2.6 (Remove Seat Back Cover)

KIT INSTALLATION

STEP 2: (VEHICLE PREP CONT'D.)

- 2.8 Remove and set aside throttle duct assembly with breather hose by loosening the clamps per fig. 2.8.

Tools

#2 Phillips Screwdriver
Pliers

- 2.9 Remove and set aside engine air filter assembly by loosening the lower clamp and removing (2) mounting screws found on the vehicle's frame per fig. 2.9.

Tools

#2 Phillips
10mm wrench or socket

- 2.10 Remove and set aside transmission intake duct assembly by loosening the lower clamp and removing (2) mounting screws found on the vehicle's frame per fig. 2.10a & 2.10b.

Tools

#2 Phillips Screwdriver

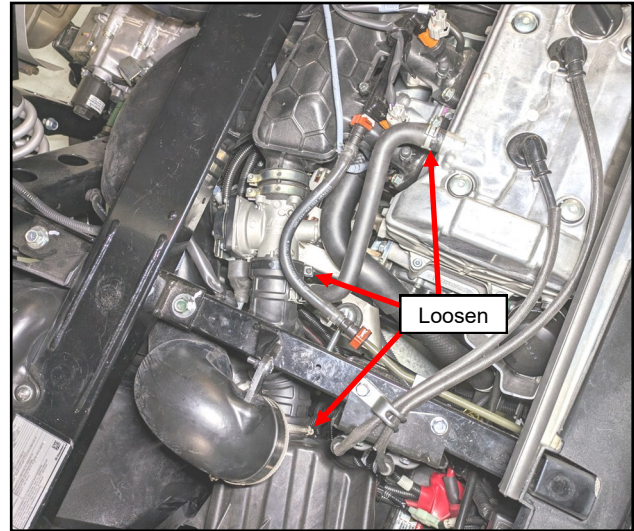

Fig. 2.8 (Remove Throttle Duct Assembly)

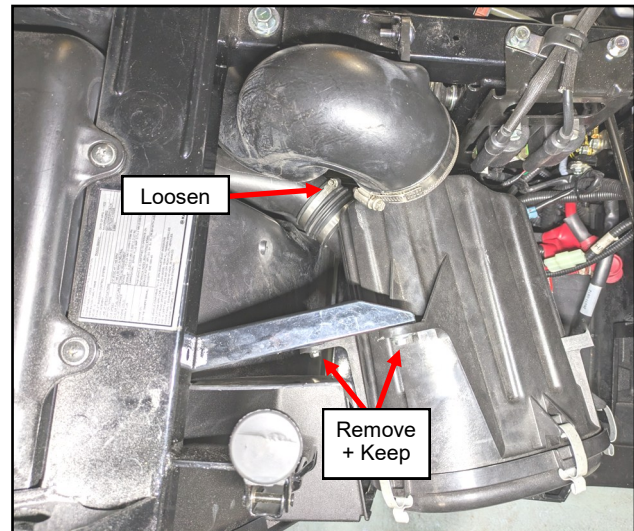

Fig. 2.9 (Remove Engine Air Filter Assembly)

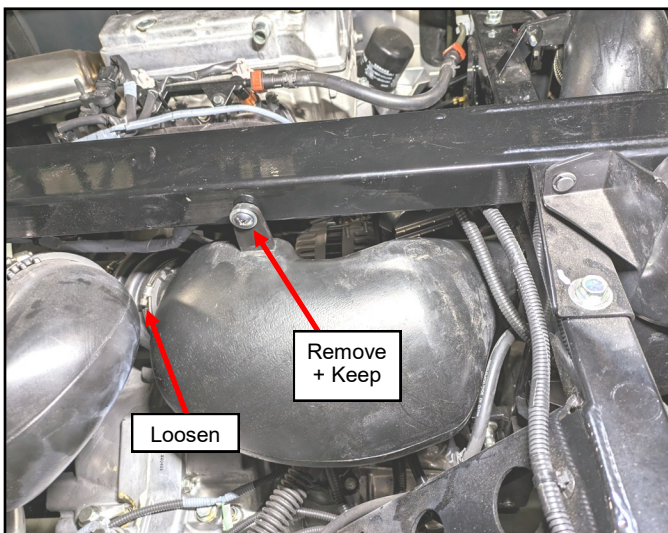

Fig. 2.10a (Remove Intake Duct Assembly, Back View)

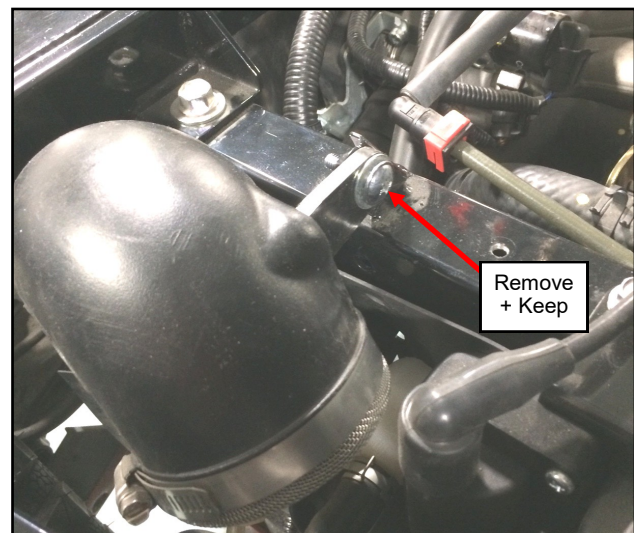

Fig. 2.10b (Remove Intake Duct Assembly, Right View)

KIT INSTALLATION

STEP 2: (VEHICLE PREP CONT'D.)

2.11 Remove and set aside belt cover by removing (3) mounting screws per fig. 2.11. Save hardware for reuse.

Tools

8mm wrench or socket

2.12 Disconnect both the alternator power wire and 2-pin connector from the back of the alternator per fig 2.12.

Tools

10mm wrench or socket

2.13 Loosen alternator mounting hardware, loosen the tensioner to rotate alternator forward, and remove factory belt per fig. 2.13.

Tools

14mm wrench or socket
6mm Allen wrench

2.14 Remove the two alternator mounting screws and remove the alternator per fig. 2.14. The alternator will fit between the upper mounting bracket and the transmission shifter cable and wiring harness below.

Tools

14mm wrench or socket

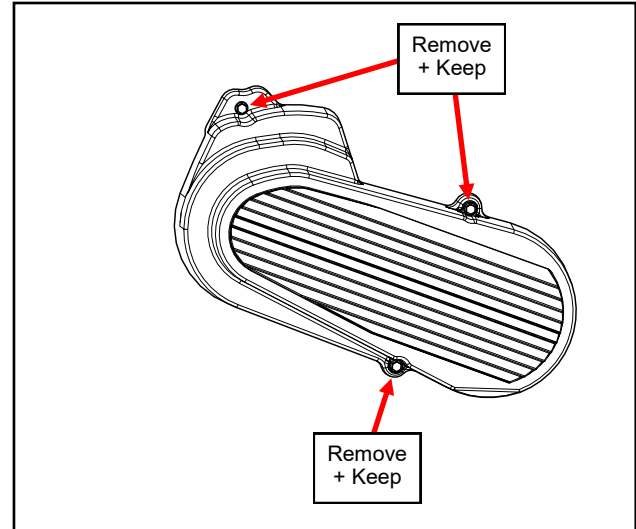

Fig. 2.11 (Remove Belt Cover)

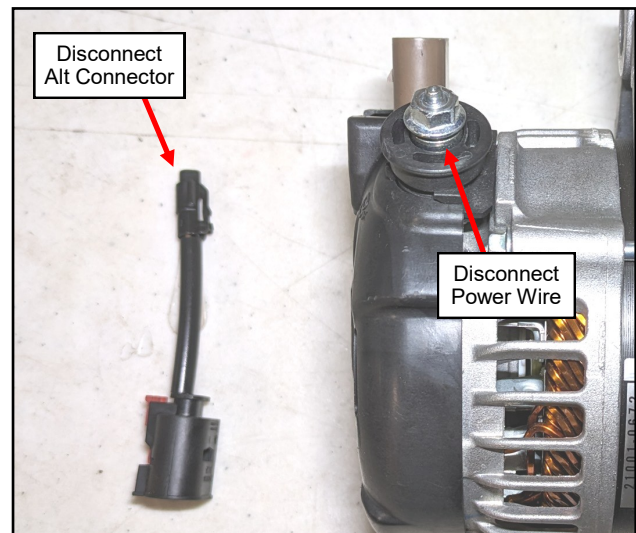

Fig. 2.12 (Disconnect Wires from Alternator)

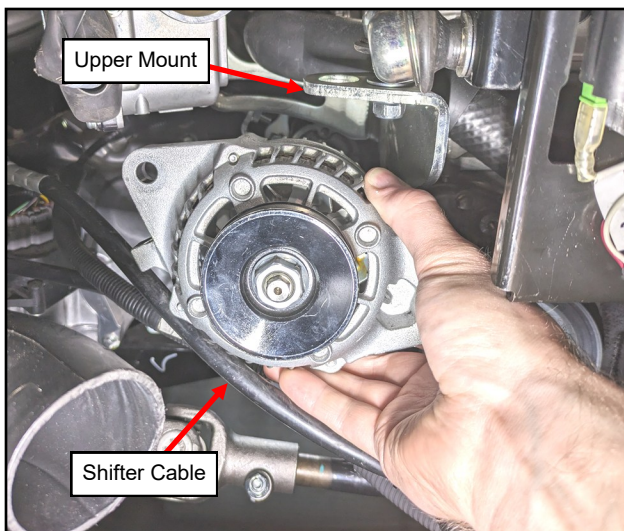

Fig. 2.14 (Remove Alternator)

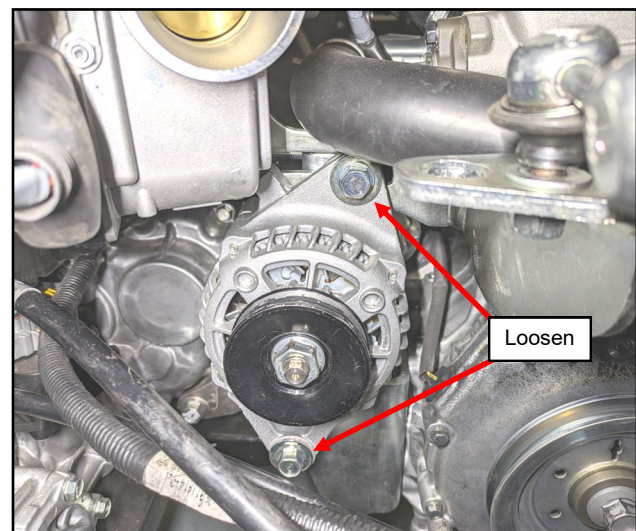

Fig. 2.13 (Loosen Alt Hardware & Remove Belt)

KIT INSTALLATION

STEP 2: (VEHICLE PREP CONT'D.)

2.15 Disconnect stabilizer rod from upper alternator mount per fig 2.15. Save the nut and washer for reuse.

Tools

14mm wrench
5mm Allen wrench

2.16 Remove upper alternator bracket per fig. 2.16. Save the mounting screws for reuse.

Tools

14mm wrench or socket

2.17 Remove lower alternator bracket per fig. 2.17. Save the mounting screws for reuse.

Tools

14mm wrench or socket

2.18 Remove and discard lower alternator bracket alignment pins per fig. 2.18.

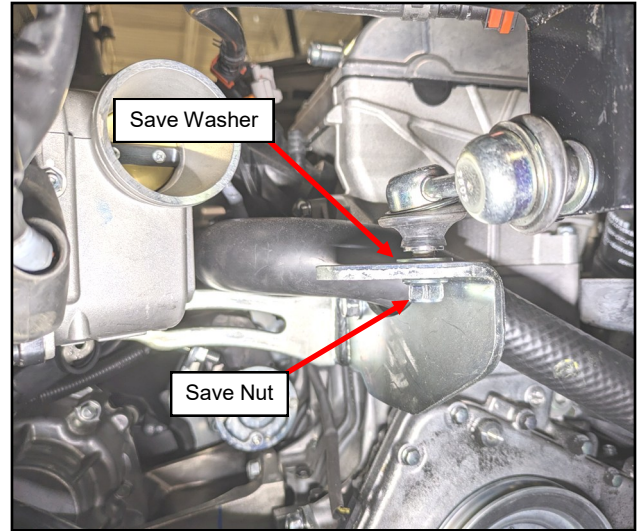

Fig. 2.15 (Disconnect Stabilizer Rod)

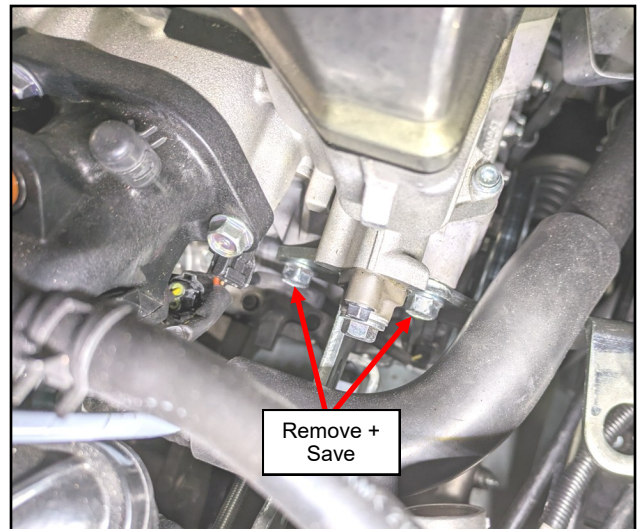

Fig. 2.16 (Remove Upper Alternator Bracket)

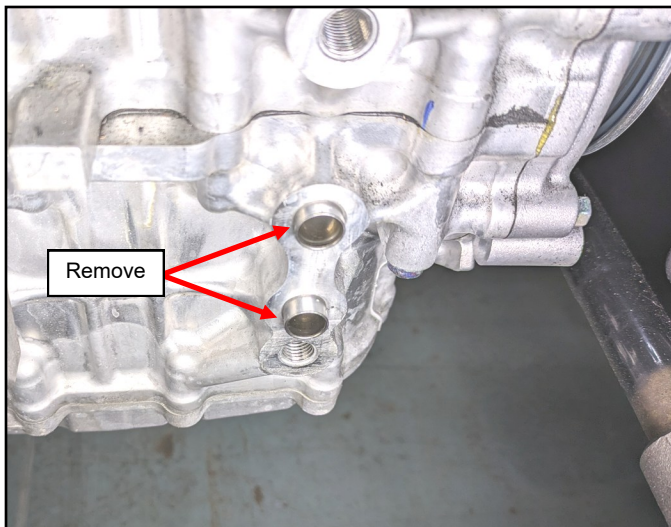

Fig. 2.18 (Remove Alignment Pins)

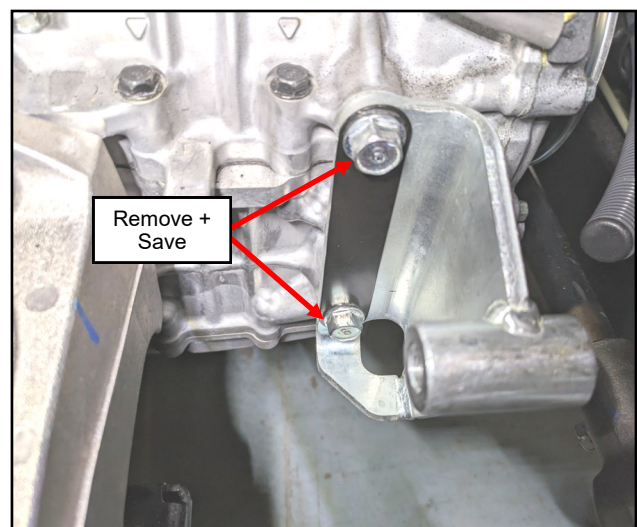

Fig. 2.17 (Remove Lower Alternator Bracket)

KIT INSTALLATION

STEP 3: (ALTERNATOR INSTALLATION)

- 3.1 Reusing OEM bolts, nut, and washer, install Upper Alternator Mounting Weldment onto engine block and stabilizer rod per figures 3.1a and 3.1b. Torque factory M8 bolts and nut to 22-31 ft-lb (30-42 Nm).

Tools

14mm wrench and socket
5mm Allen wrench
Torque Wrench

- 3.2 Reusing OEM bolts, install Lower Alternator Mounting Weldment onto engine block per figure 3.2. Torque factory M8 bolts to 22-31 ft-lb (30-42 Nm).

Tools

14mm socket
Torque Wrench

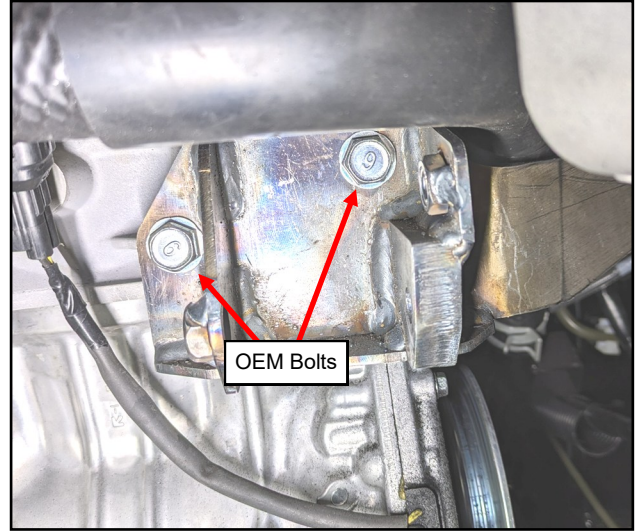

Fig. 3.1a (Install Upper Alternator Mount)

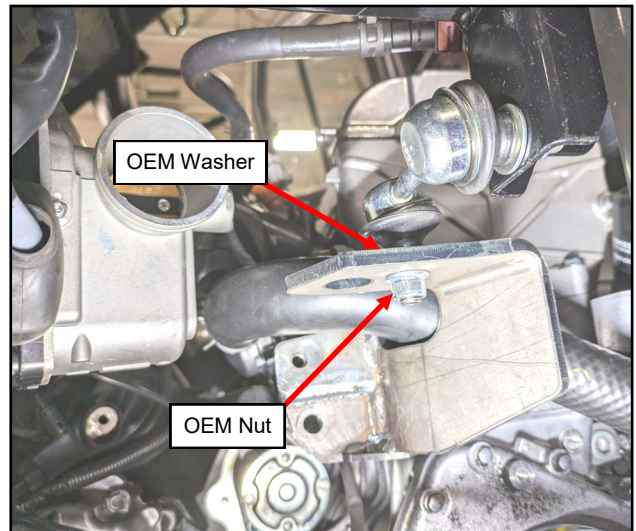

Fig. 3.1b (Install Upper Alternator Mount)

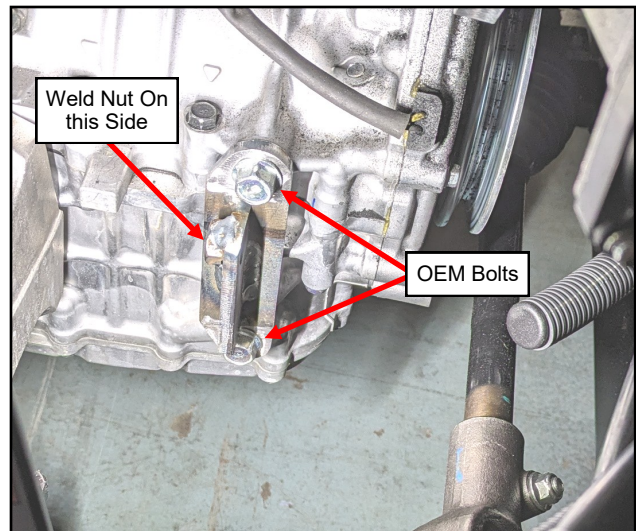

Fig. 3.2 (Install Lower Alternator Mount)

KIT INSTALLATION

STEP 3: (ALTERNATOR INSTALLATION CONT'D.)

- 3.3 Assemble the new alternator tensioner using the OEM alternator adjuster bracket and the flat and split lock washers from the adjuster bolt. See figures 3.3a and 3.3b. The OEM adjuster bolt is not used.

<u>Hardware Used</u>	<u>Qty</u>
M8x1.25 X 90mm Hex Bolt	1

- 3.4 Install the alternator tensioner onto the lower alternator mount. See figure 3.4. **Note:** Do not fully tighten hardware.

<u>Hardware Used</u>	<u>Qty</u>
3/8-16 X 1" Flange Bolt (Black)	1

Tools
9/16" wrench or socket

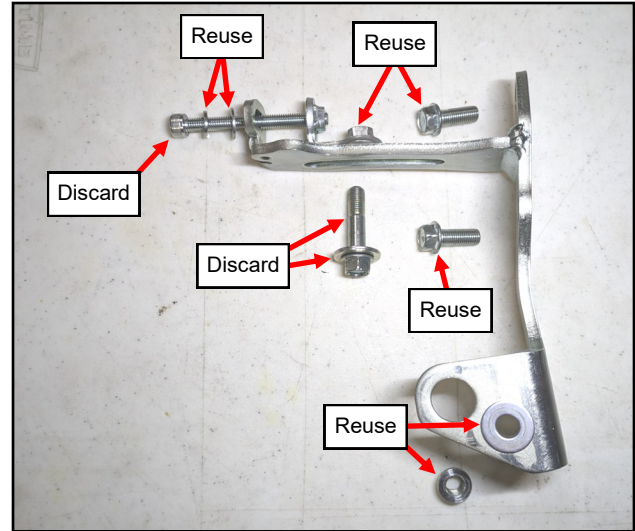

Fig. 3.3a (Disassemble OEM Upper Mount)

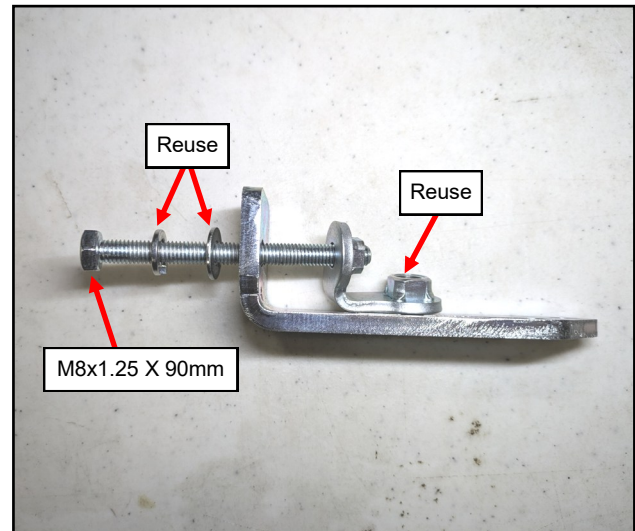

Fig. 3.3b (Assemble New Alternator Tensioner)

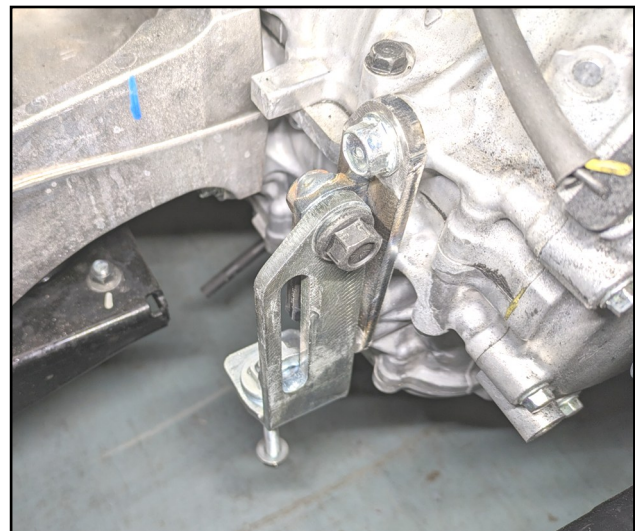

Fig. 3.4 (Install Alternator Tensioner)

KIT INSTALLATION

STEP 3: (ALTERNATOR INSTALLATION CONT'D.)

- 3.5 Install the alternator signal wire harness to the alternator as shown in figure 3.5.
- 3.6 Insert alternator with signal wire harness into the engine compartment from the side below the shifter cable as shown in figure 3.6.
- 3.7 Install the alternator into the upper alternator mount as shown in figure 3.7. **Note:** Do not fully tighten hardware.

Hardware Used

3/8-16 X 3" Flange Bolt (Black)

Qty

1

Tools

9/16" wrench or socket

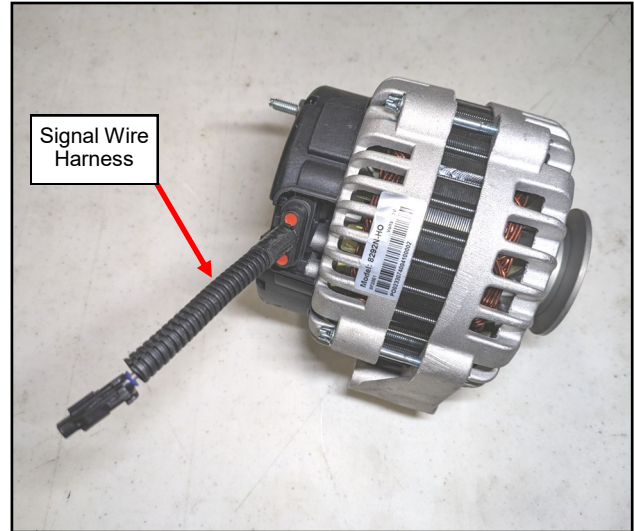

Fig. 3.5 (Connect Signal Wire Harness to Alternator)

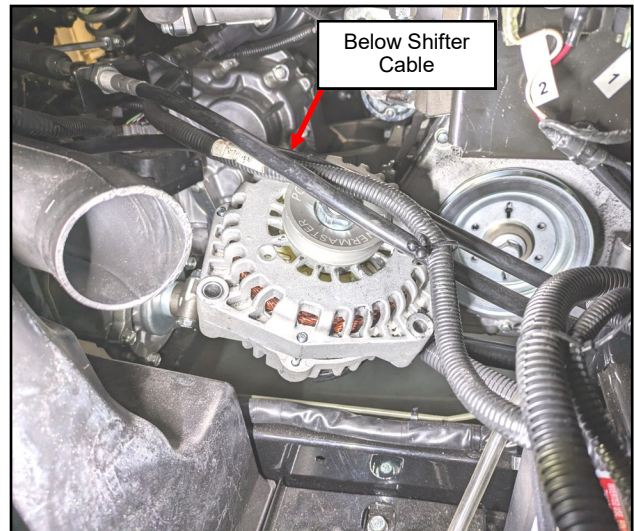

Fig. 3.6 (Insert Alternator into Engine Component)

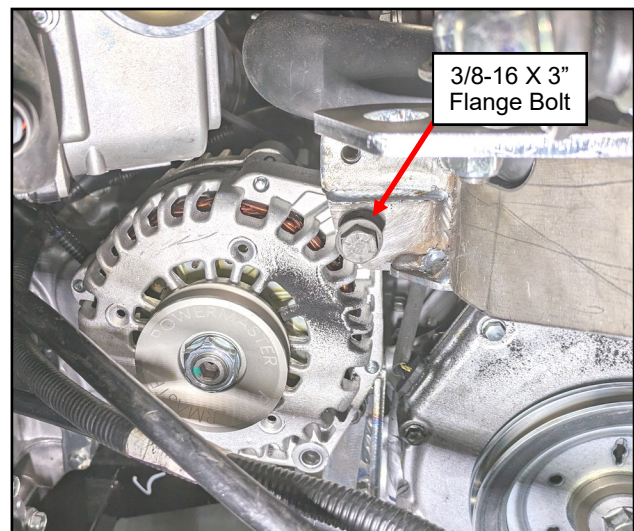

Fig. 3.7 (Install Upper Alternator Bolt)

KIT INSTALLATION

STEP 3: (ALTERNATOR INSTALLATION CONT'D.)

- 3.8** Rotate the tensioner up enough to install the lower alternator bolt. See figure 3.8. The M8 tensioning bolt might need to be adjusted, and the alternator might need to be rotated, to get everything lined up. **Note:** Do not fully tighten hardware.

<u>Hardware Used</u>	<u>Qty</u>
M10x1.25 X 70mm Flange Bolt (Clear Zinc)	1

Tools

14mm wrench or socket

- 3.9** Loosen the tensioner so the alternator is rotated all the way down and install new belt provided in kit. See figure 3.9.

- 3.10** Adjust the M8 tensioner bolt to tension the belt. See figure 3.10. Place a straight edge tangent to crank pulley and alternator. Place belt tension tester in the center and perpendicular to the belt between the (2) pulleys and next to the straight edge. Push the tester towards the theoretical center making sure that a deflection force of 3.1 lbs. gets .2 inches of belt deflection at the center of the belt. See Figure 3.10. Torque all 3/8-16 and M10 hardware to the following 38-46 ft-lb (52-62 Nm) and verify correct tension.

Tools

9/16" socket
13mm socket
14mm socket
Belt tensioner tester
Straight edge

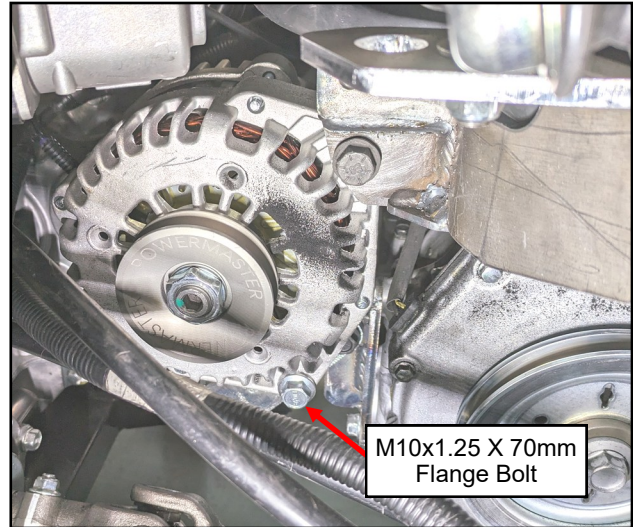

Fig. 3.8 (Install Lower Alternator Bolt)

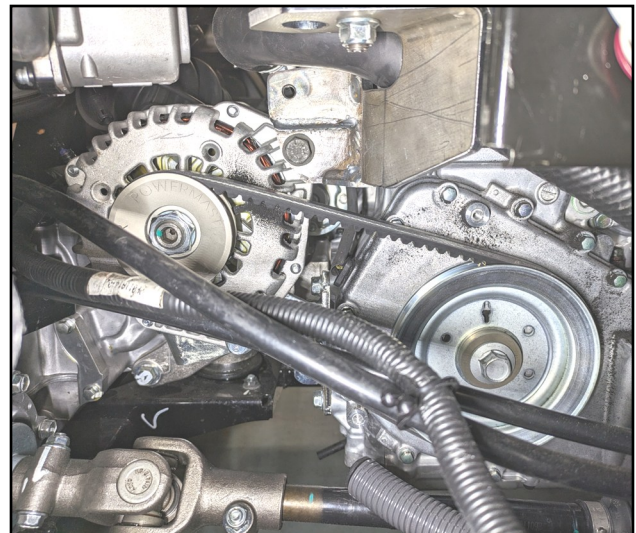

Fig. 3.9 (Install Belt)

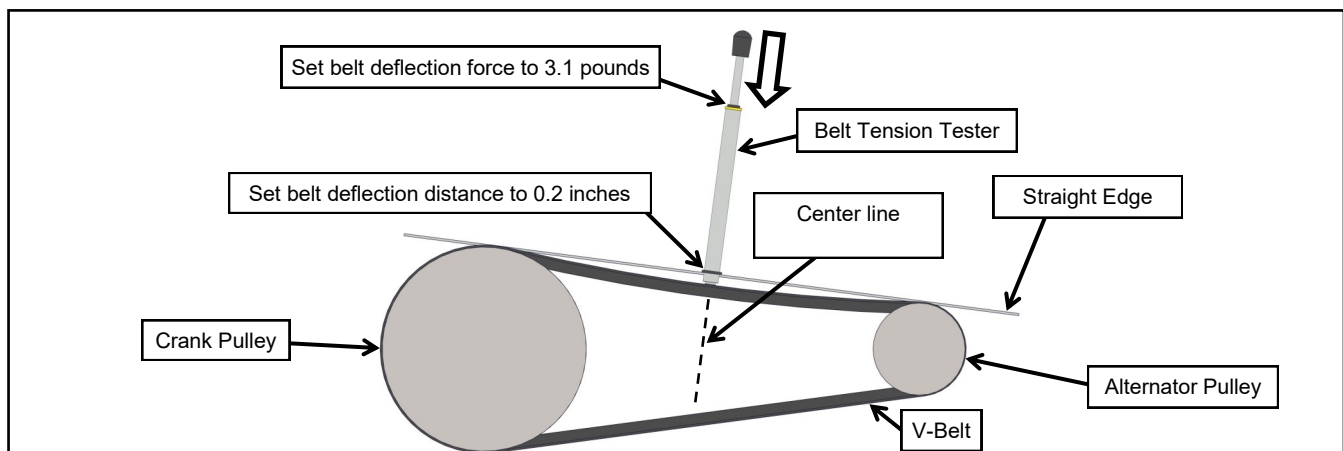

Fig. 3.10 (Tension Alternator V-Belt)

KIT INSTALLATION

STEP 3: (ALTERNATOR INSTALLATION CONT'D.)

- 3.11 Start applying the belt cover trim template decal at the bottom of the belt cover as shown in figure 3.11.
- 3.12 Fold the decal over the edges of the belt cover and then wrap it around to the other side. See figure 3.12. One edge of the decal should run along the tangent edge of the inner belt cover corner, while the other edge should be about even with the outside face of the belt cover.
- 3.13 Wrap the decal around the side surface of the belt cover so that it ends at the top as shown in figure 3.13.

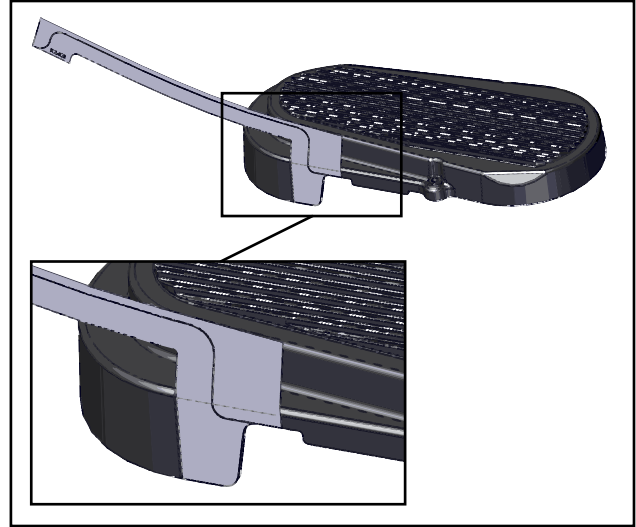

Fig. 3.11 (Start Applying Trim Template Decal)

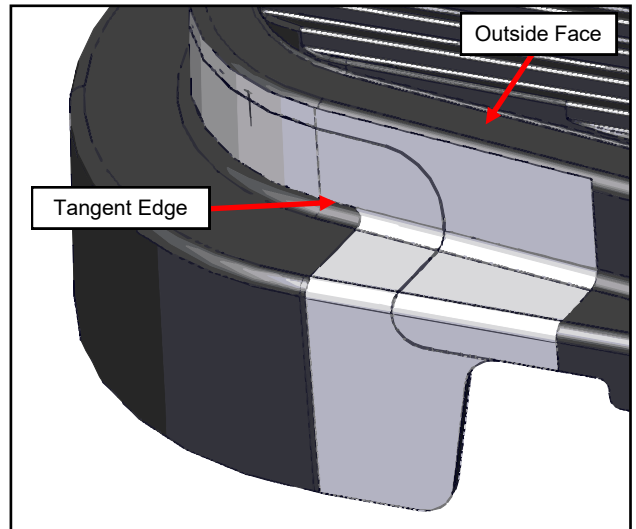

Fig. 3.12 (Fold Trim Template Decal)

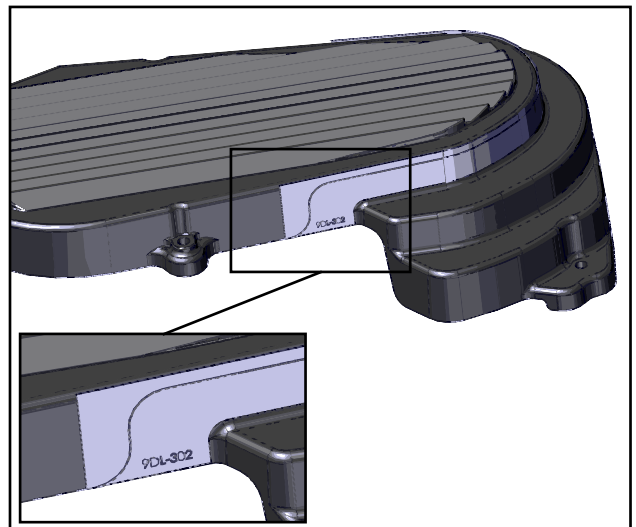

Fig. 3.13 (Wrap Decal Around to Top)

KIT INSTALLATION

STEP 3: (ALTERNATOR INSTALLATION CONT'D.)

3.14 Trim the belt cover along the line on the decal. See figure 3.14.

Tools

Plastic-cutting saw of choice

3.15 Place the belt cover extension onto the trimmed belt cover and mark the rivet hole locations. See figure 3.15. The bottom surface shown should be tight to the surface of the belt cover. Drill the (5) holes using a 3/16" drill bit.

Tools

Drill with 3/16" drill bit

3.16 Line the cover extension back up to the belt cover and install the rivets into the plastic.

Hardware Used

3/16" x 5/16" Dome Head Rivets

Qty

5

Tools

Pop Riveter with 3/16" insert

3.17 Install the belt cover onto the engine using the OEM belt cover bolts removed earlier. See figure 3.17.

Tools

8mm wrench or socket

Alternator kit prep is complete. Continue with Cab installation at this time.

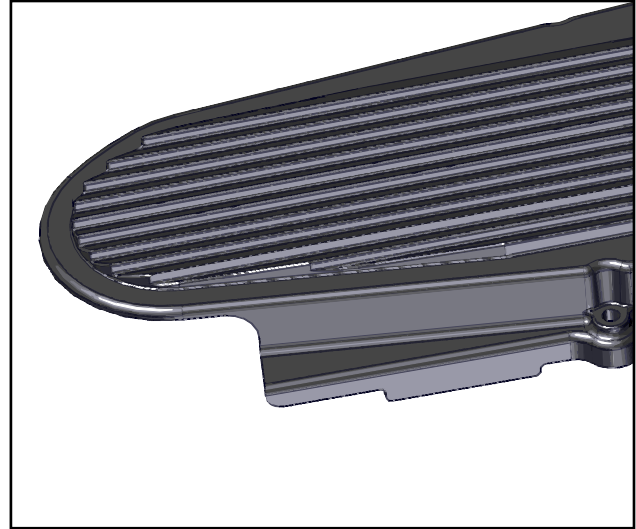

Fig. 3.14 (Trimmed Belt Cover)

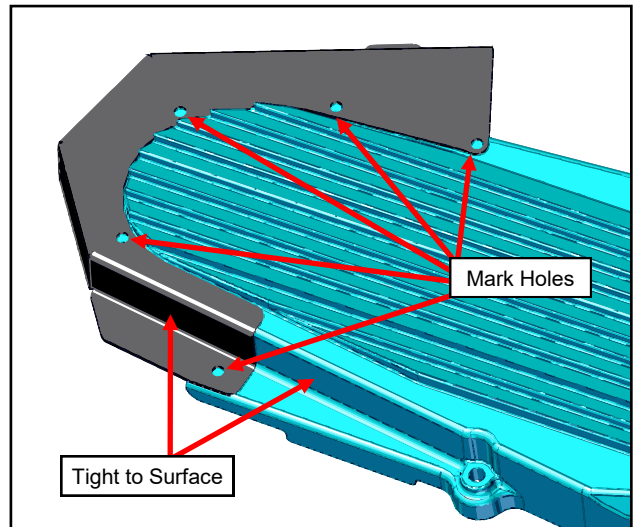

Fig. 3.15 (Mark Rivet Holes Using New Cover Extension)

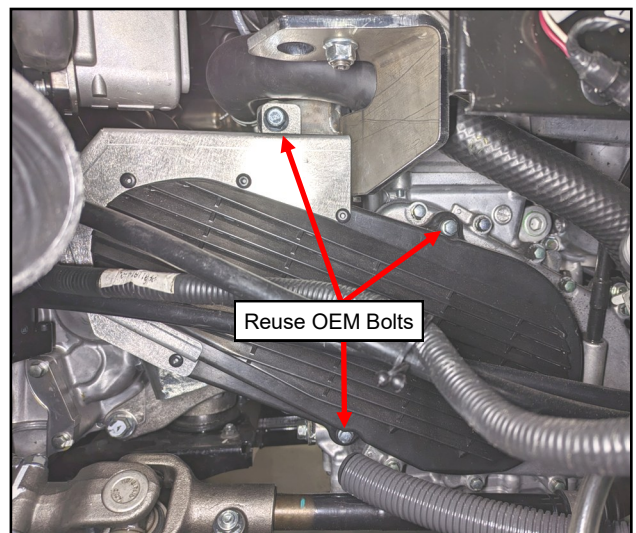

Fig. 3.17 (Install Belt Cover)

KIT INSTALLATION

STEP 4: (ALTERNATOR WIRING)

Once Cab and A/C Roof Unit are installed, continue with the A/C install as directed here:

- 4.1 Unbolt positive wires from the positive battery terminal. Make sure the battery terminal is oriented as shown in figure 4.1. Loosen and rotate if necessary.

Tools

10mm wrench or socket

- 4.2 Push one end of the supplied alternator power wire through the red OEM positive terminal boot as shown in figure 4.1. Prepare for the fuse mounting bar by placing the supplied thick washer between the battery terminal and the alternator power wires.

Hardware Used

.257x.625, .125 Thick Washer

Qty

1

- 4.3 Install Fuse Mounting Bar and both OEM and new alternator power wires to the positive terminal using the new larger head bolt provided. See fig 4.3.

Hardware Used

M6x1 X 20mm Flange Bolt

Qty

1

Tools

10mm wrench or socket

- 4.4 Slide the provided red terminal boot over the cab side A/C Power Supply harness and install it to the fuse mounting bar with the 100 amp fuse as shown in figure 4.4.

Hardware Used

1/4-20 Lock Nut (Clear Zinc)

Qty

1

Tools

7/16" wrench or socket

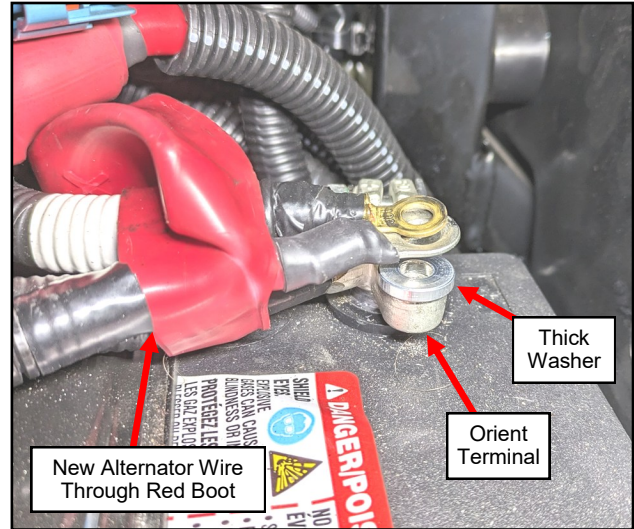

Fig. 4.1 (Install Positive Wires)

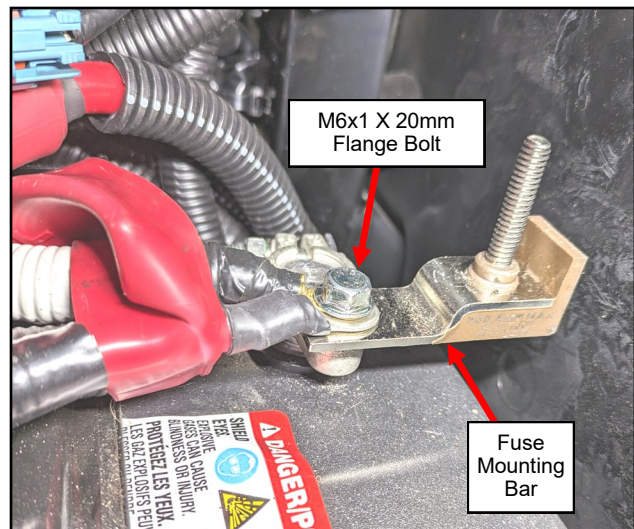

Fig. 4.3 (Install Fuse Mounting Bar)

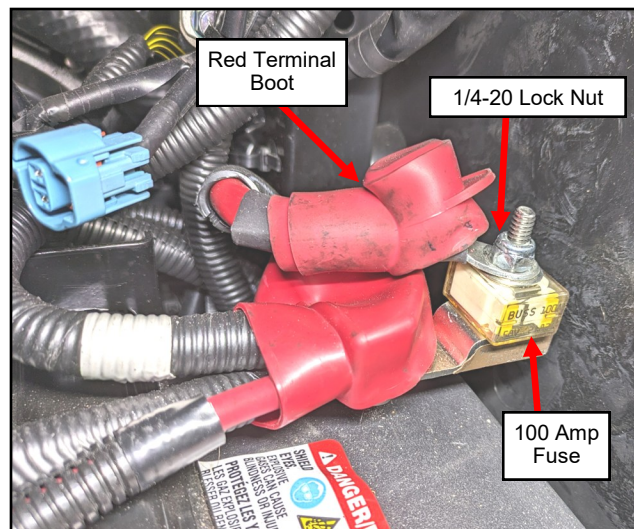

Fig. 4.4 (Install 100 Amp Fuse and A/C Power Wire)

KIT INSTALLATION

STEP 4: (POWER CONNECTIONS CONT'D.)

- 4.5 Route the new alternator wire along the OEM alternator wire as shown in fig 4.5. Secure with supplied zip ties.
- 4.6 Push the new alternator wire through the boot of the OEM alternator wire. See figure 4.6.
- 4.7 Connect the new and OEM alternator wires together onto the alternator stud. Also connect the alternator signal jumper wire to the OEM alternator signal wire. See figure 4.7.

Tools

10mm wrench or socket

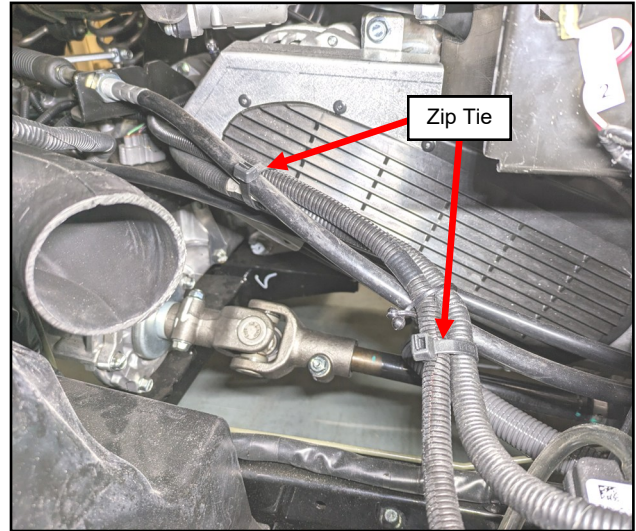

Fig. 4.5 (Secure New Alternator Wire)

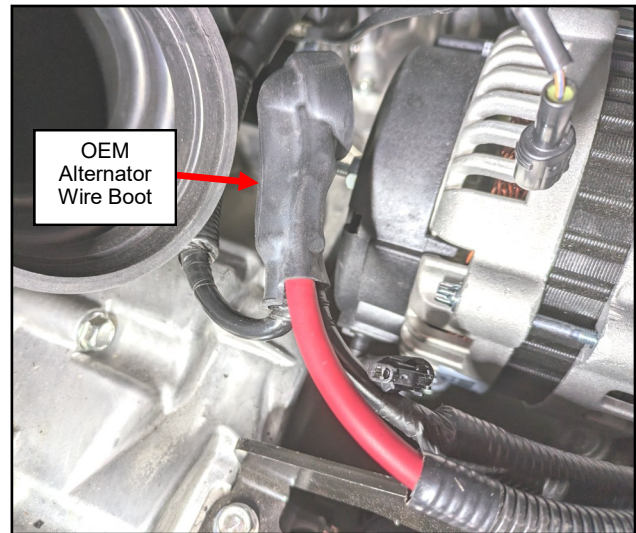

Fig. 4.6 (Push New Alternator Wire Through Boot)

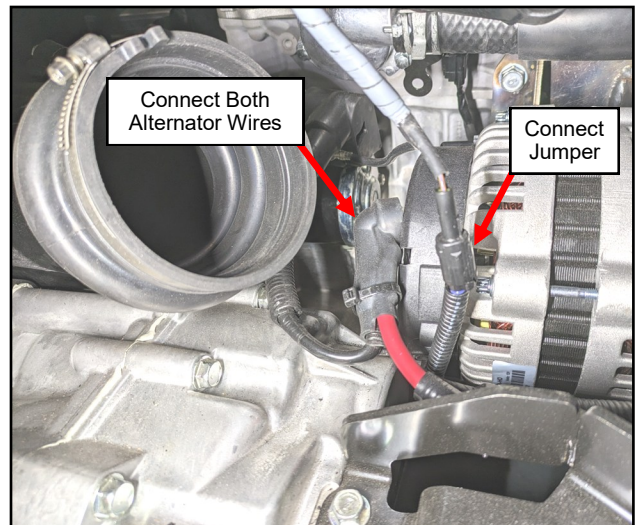

Fig. 4.7 (Connect Alternator Wires and Signal Jumper)

KIT INSTALLATION

STEP 4: (POWER CONNECTIONS CONT'D.)

- 4.8 Locate the Alternator Harness (has fuse holder). See figure 4.8.
- 4.9 Secure the fuse holder to the vehicle as shown in figure 4.9. Locate the purple wire on the A/C Power Supply Wire Harness and connect with the mating terminal on the Alternator Harness from the previous step. Note: the brown wire with the 4 pin connector will not be used. See fig. 4.9.
- 4.10 Connect the white connector of the Signal Wire Harness to the white connector of the Alternator Harness. Connect the gray connector on the Signal Wire Harness to the blue connector on the vehicle harness. See figure 4.10.

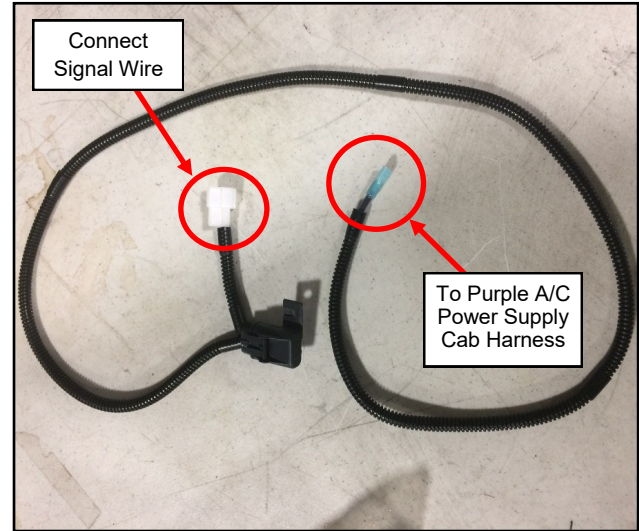

Fig. 4.8 (Alternator Harness)

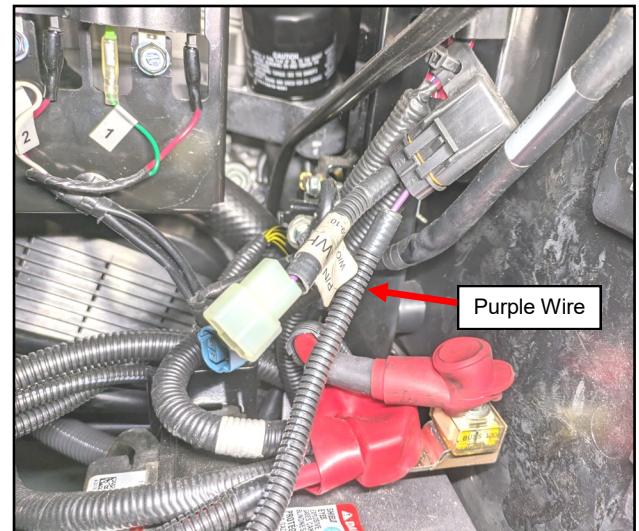

Fig. 4.9 (Alternator Harness)

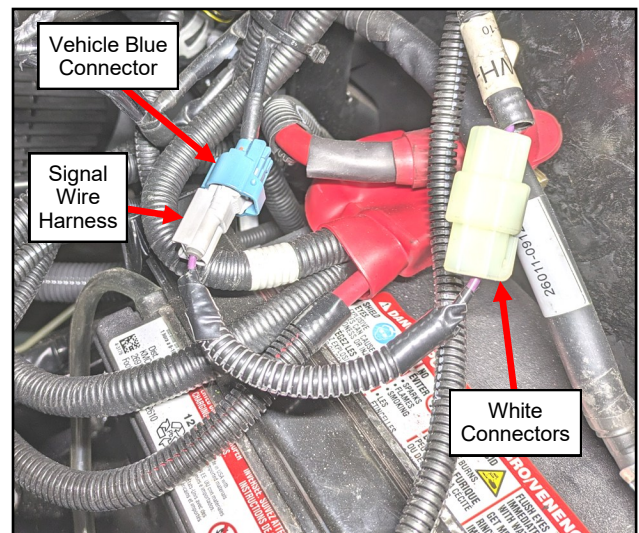

Fig. 4.10 (Connect Signal Wire Harness)

KIT INSTALLATION

STEP 4: (POWER CONNECTIONS CONT'D.)

4.11 Replace the negative battery terminal bolt with the longer one supplied and reconnect the negative battery terminal. See figure 4.11.

Hardware Used **Qty**
 5/16-18 X 1.25" square head bolt 1

Tools
 1/2" wrench or socket

4.12 Install the ring terminal on the heavy black wire on the A/C Power Supply harness. See figure 4.12.

Hardware Used **Qty**
 5/16-18 serrated flange nut 1

Tools
 1/2" wrench or socket

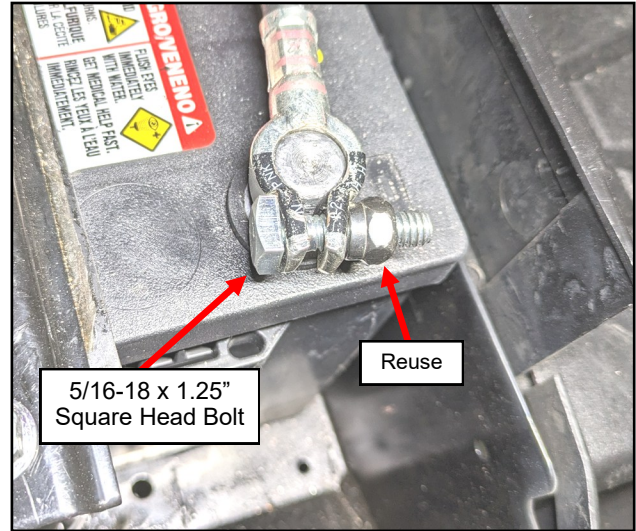

Fig. 4.11 (Install Ground Terminal)

STEP 5: (FINISHING TOUCHES)

- 5.1 Inspect all fasteners, they should be fully tightened before starting the vehicle.
- 5.2 Inspect all wires to make sure they are sufficiently tied down and away from hot or moving parts.
- 5.3 Re-install Transmission Intake Duct, Air Filter Assembly, Throttle Duct, and Battery Cover, which were previously removed in Step 2 section.
- 5.4 Tilt the vehicle's bed back down and re-latch the bed. On Pro-FXT, tilt rear seat back and re-latch.
- 5.5 See figure below. Start the vehicle and turn on the air conditioner. Run the engine at idle. Cool air should begin to flow after 60 to 90 seconds. Verify that the air conditioner is functioning. If it is not functioning, refer to the troubleshooting section in the A/C manual.

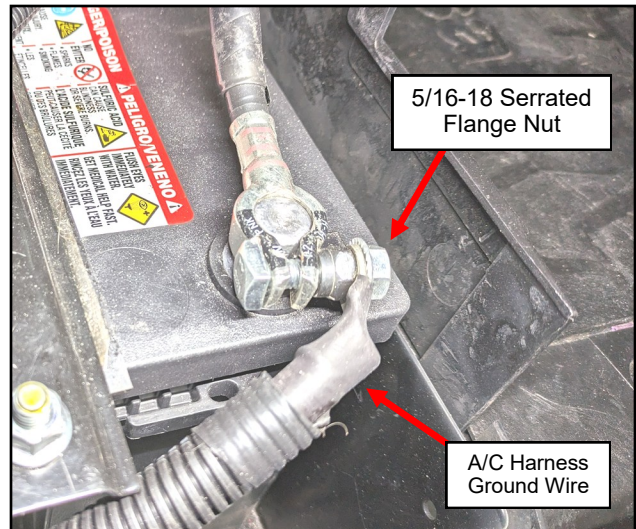
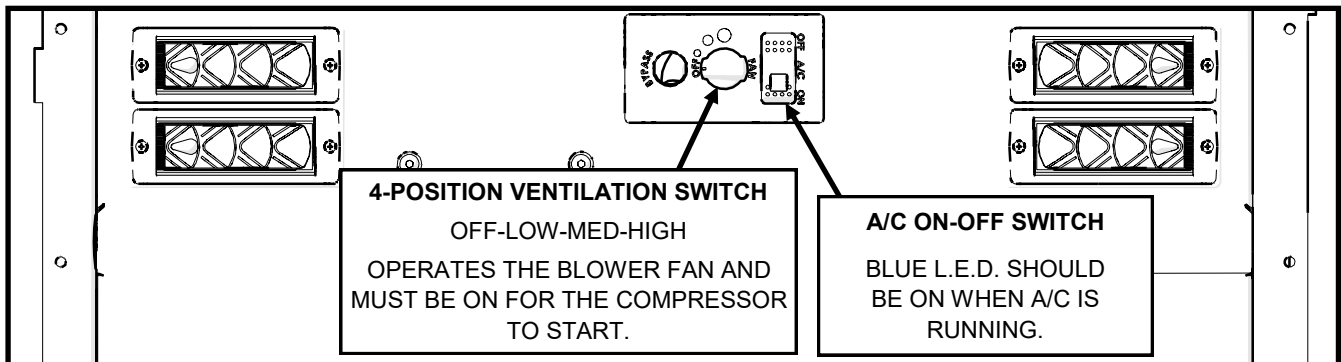

Fig. 4.12 (Install A/C Power Supply Harness Ground)

Alternator kit is now complete. Continue with the completion of the cab and roof kit installations.



CARE AND MAINTENANCE

- Readjust the belts after the initial 8-10 hours of vehicle use.
- Check and tighten hardware after 20 hours of vehicle operation. Periodically inspect and tighten hardware for the remainder of the unit's life.

KAWASAKI MULE PRO-FX & PRO-FXT A/C ALTERNATOR KIT SERVICE PARTS

ALT. MOUNTING WELDMENT, LOWER
P/N: 8SV-WA-00743-ZC

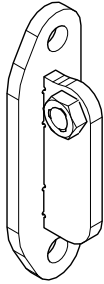

ALT. MOUNTING WELDMENT, UPPER
P/N: 8SV-WA-00747-ZC

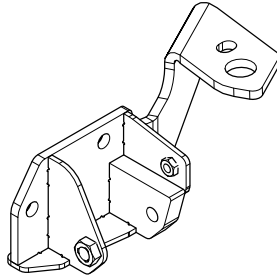

ALTERNATOR TENSIONER ARM
P/N: 8SV-SM-03052-ZC

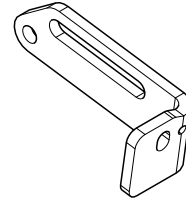

ALTERNATOR, AD244 FRAME, 200 AMP
P/N: 8SV-114-00053

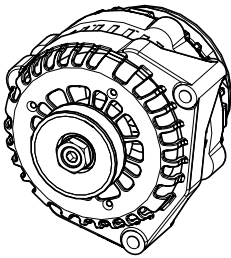

BELT, V-BELT, 30.13" OUTSIDE CIRCLE
P/N: 9SV-9BLT-19

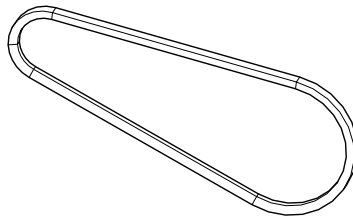

DECAL, BELT COVER CUT TEMPLATE
P/N: 9SV-9DL-302

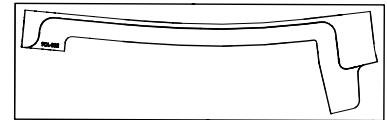

BELT COVER EXTENSION
P/N: 8SV-SM-03068

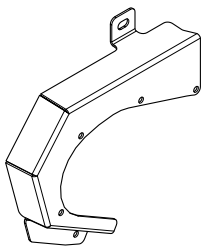

FUSE, 100 AMP, 58 VOLT, MARINE RATED
BATTERY, IP66; P/N: 9SV-85-00-0050

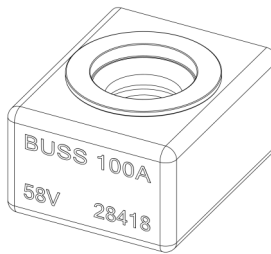

FUSE MOUNTING BAR, 58 VOLT, 1/4" STUD,
3/8" MOUNTING HOLE; P/N: 9SV-85-16-0051

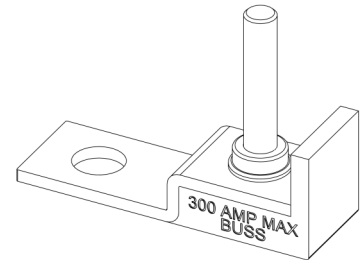

JUMPER HARNESS
P/N: 9SV-WH-00094

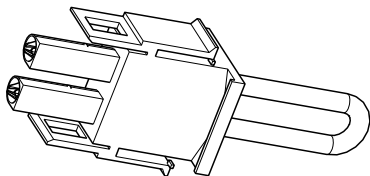

WIRE HARNESS, A/C POWER SUPPLY,
CAB SIDE, ACMRX; P/N: 9SV-WH-00096

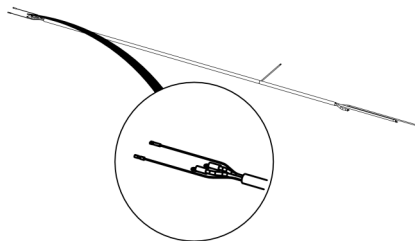

ALTERNATOR HARNESS, KAWASAKI
MULE PRO-FX; P/N: 9SV-WH-00116

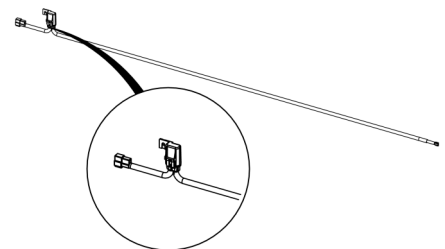

KAWASAKI MULE PRO-FX & PRO-FXT A/C ALTERNATOR KIT SERVICE PARTS

WIRE HARNESS, ALT. TO BATTERY
P/N: 9SV-WH-00159

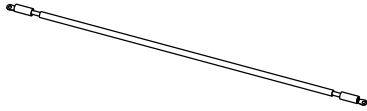

WIRE HARNESS, ALT. SIGNAL WIRE
P/N: 9SV-WH-00160

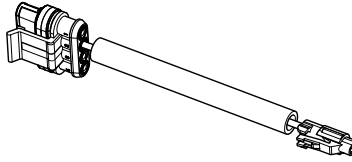

WIRE HARNESS, KEYED
IGNITION WIRE ADAPTER
P/N: 9SV-WH-00161

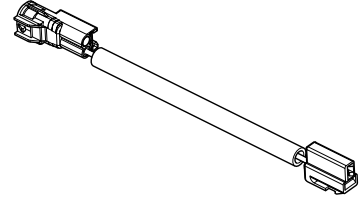

TUBE CAPS (BAG OF 10)
9SV-74-01-0010

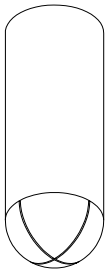

DRAIN HOSE
9SV-AC-00019-15
(15 feet)

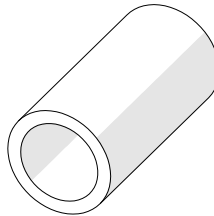

TRIM-LOK, STD, 1/16" - 1/8" GRIP
P/N: 9SV-PRO1-20
(20 feet)

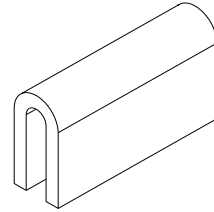



BOLT TORQUE

BOLT TORQUE SPECIFICATIONS

GENERAL TORQUE SPECIFICATION TABLE

Use the following torques when special torques are not given. These values apply to fasteners as received from suppliers, dry, or when lubricated with normal engine oil. They do not apply if special graphited or moly disulphide greases or other extreme pressure lubricants are used. This applies to both UNF and UNC threads. Remember to always use grade five or better when replacing bolts.

IMPORTANT: On all PLATED GRADE 8 bolts, reduce torque 15% from listed bolt torque specification.

SAE Grade No.		2				5				8*			
Bolt head identification mark as per grade. NOTE: Manufacturing Marks Will Vary													
		TORQUE		TORQUE		TORQUE		TORQUE		TORQUE		TORQUE	
Bolt Size		Pounds Feet		Newton-Meters		Pounds Feet		Newton-Meters		Pounds Feet		Newton-Meters	
Inches	Millimeters	Min.	Max.	Min.	Max.	Min.	Max.	Min.	Max.	Min.	Max.	Min.	Max.
1/4	6.35	5	6	7	8	9	11	12	15	12	15	16	20
5/16	7.94	10	12	14	16	17	20.5	23	28	24	29	33	39
3/8	9.53	20	23	27	31	35	42	48	57	45	54	61	73
7/16	11.11	30	35	41	47	54	64	73	87	70	84	95	114
1/2	12.70	45	52	61	70	80	96	109	130	110	132	149	179
9/16	14.29	65	75	88	102	110	132	149	179	160	192	217	260
5/8	15.88	95	105	129	142	150	180	203	244	220	264	298	358
3/4	19.05	150	185	203	251	270	324	366	439	380	456	515	618
7/8	22.23	160	200	217	271	400	480	542	651	600	720	814	976
1	25.40	250	300	339	406	580	696	787	944	900	1080	1220	1464
1-1/8	25.58	-	-	-	-	800	880	1085	1193	1280	1440	1736	1953
1-1/4	31.75	-	-	-	-	1120	1240	1519	1681	1820	2000	2468	2712
1-3/8	34.93	-	-	-	-	1460	1680	1980	2278	2380	2720	3227	3688
1-1/2	38.10	-	-	-	-	1940	2200	2631	2983	3160	3560	4285	4827

*Thick Nuts must be used with Grade 8 bolts

METRIC BOLT TORQUE SPECIFICATIONS



Size of Screw	Property Class	Course Thread			Fine Thread		
		Pitch (mm)	Pounds Feet	Newton-Meters	Pitch (mm)	Pounds Feet	Newton-Meters
M6	5.6	1.0	3.6-5.8	4.9-7.9	-	-	-
	8.8		5.8-9.4	7.9-12.7		-	-
	10.9		7.2-10	9.8-13.6		-	-
M8	5.6	1.25	7.2-14	9.8-19	1.0	12-17	16.3-23
	8.8		17-22	23-29.8		19-27	25.7-36.6
	10.9		20-26	27.1-35.2		22-31	29.8-42
M10	5.6	1.5	20-25	27.1-33.9	1.25	20-29	27.1-39.3
	8.8		34-40	46.1-54.2		35-47	47.4-63.7
	10.9		38-46	51.5-62.3		40-52	54.2-70.5
M12	5.6	1.75	28-34	37.9-46.1	1.25	31-41	42-55.6
	8.8		51-59	69.1-79.9		55-68	75.9-92.1
	10.9		57-66	77.2-89.4		62-75	84-101.6
M14	5.6	2.0	49-56	66.4-75.9	1.5	52-64	70.5-86.7
	8.8		81-93	109.8-126		90-106	122-143.6
	10.9		96-109	130.1-147.7		107-124	145-168
M16	5.6	2.0	67-77	90.8-104.3	1.5	69-83	93.6-112.5
	8.8		116-130	157.2-176.2		120-138	162.6-187
	10.9		129-145	174.8-196.5		140-158	189.7-214.1
M18	5.6	2.0	88-100	119.2-136	1.5	100-117	136-158.5
	8.8		150-168	203.3-227.6		177-199	239.8-269.6
	10.9		175-194	237.1-262.9		202-231	273.7-313
M20	5.6	2.5	108-130	146.3-176.2	1.5	132-150	178.9-203.3
	8.8		186-205	252-277.8		206-242	279.1-327.9
	10.9		213-249	288.6-337.4		246-289	333.3-391.6