



Kubota L47 TLB Cab P/N: 1KTLBL47

While this cab kit was designed to fit on the vehicle(s) listed above, manufacturing tolerances and vehicle assembly may affect cab fitment. It is the responsibility of the cab installer to check all vehicle pedals and levers for full functionality and, as required, adjust the cab fitment to prevent any interference of the cab components with the travel of pedals or levers.



Shown with Optional Front and Rear Round LED Work Lights

Available Options:

1. Rear Closeout Panel for Operation When Backhoe is Removed (P/N: 1KTLBL47RP)
2. Optional Rear Hydraulics Closeout panel for tractors with optional rear remote hydraulics installed (P/N: 1KTLBL47HYD)
3. Front or rear Round LED Work Lights (fits both L47 and M62) (P/N: 1KTLBLEDWL) (shown above)

Approximate Installation Time *

Experienced Dealer Technician – 6-8 Hours

Average Dealer Technician – 8-10 Hours

Do-It-Yourself – 10-14 Hours

(*=Not including accessories)

Approximate Product Specifications

Fits Under the Factory Roof

Weight: 584 lbs.

Cab Width: 60-1/2" (3-1/2" wider than right fender)

The contents of this envelope are the property of the owner. Leave with the owner when installation is complete.

Rev. G, 04-13-2022

p/n: IM-1KTLBL47

TABLE OF CONTENTS

TABLE OF CONTENTS	2
INTRODUCTION	3
SAFETY INFORMATION	3-4
GENERAL INFORMATION	5
INSTALLATION	6-23
OPERATION	24-30
TROUBLESHOOTING	31
SERVICE PARTS BREAKDOWN	32-36
TORQUE CHART	37

INTRODUCTION

Curtis cabs feature an assembly of parts designed for your vehicle which require adjustment and alignment of components to accommodate vehicle variations and provide proper weather protection. For accurate installation, proper operation, and years of satisfaction, please read and understand the installation and owner's manual fully prior to installing the cab.

From all of us at Curtis, we thank you for choosing our product.



SAFETY INFORMATION



WARNING:

- Read and understand this entire manual and any other publications for the equipment being operated.
- This cab enclosure adds additional weight to the base vehicle. Deduct the accessory's total weight (see front cover) from the vehicle's rated capacity including operator. Never operate the vehicle outside of its rated weight capacity.
- Use proper personal protective equipment during all phases of installation, removal and operation.
- Ensure that the surrounding area is clear and that personnel are positioned away from the area where engagement and disengagement of attachments will occur.
- Always shut off engine when leaving the operator's area to perform any portion of the listed procedures.
- **Exposure to Carbon Monoxide can cause illness, serious injury or death.** Never operate vehicle if suspicious of Carbon Monoxide. Inspect exhaust system for leaks monthly. Leaks can result from loose connections, corrosion, cracks or other damage to the exhaust manifold. If leaks are found, repair or replace exhaust system. Do not use vehicle until repair or replacement is complete.

Serious injury or death:

- This cab enclosure does not provide protection from rollover or other accidents.
- This cab enclosure does not provide protection from flying objects including golf balls.
- This cab enclosure does not provide protection from lightning. When lightning threatens, take cover and do not operate vehicle.

California Proposition 65



Engine exhaust, some of its constituents, certain vehicle components and fluids, contain or emit chemicals known to the State of California to cause cancer and birth defects or other reproductive harm.

DECALS AND PLACEMENT

IMPORTANT: Keep all decals clean and legible. Replace all missing, illegible, or damaged decals.

IMPORTANT: Decal placement locations shown are approximate; decals should not be placed in a location where the operator's field of view is impeded, and should not cover any portion of other decals installed in the same vicinity.

INSTALLING OR REPLACING DECALS: Thoroughly clean the area where decal is to be placed using mild soap and water. Allow the surface to fully dry. Remove the backing from the decal, exposing the adhesive surface. Apply the decal to the recommended position shown in the diagram below and smooth out any bubbles.

- 1) WARNING: CRUSH POINT (9DL-196)

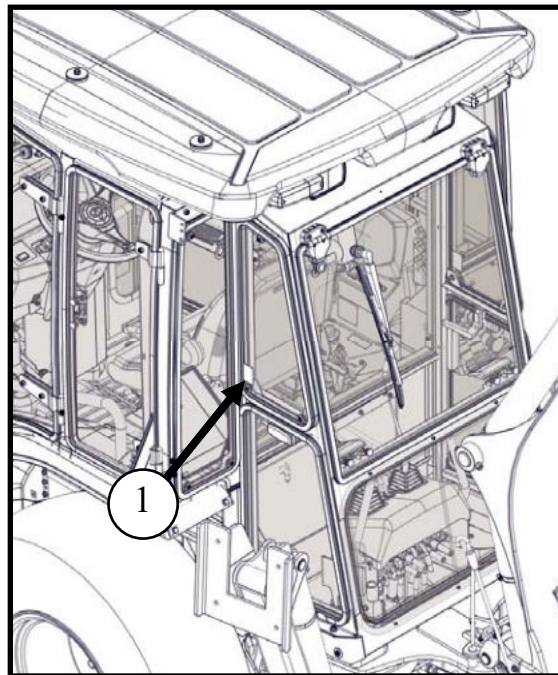

CARE & MAINTENANCE

Check and tighten all hardware after 20 hours of operation. Periodically inspect and tighten hardware for the remainder of the unit's service life. Keep the enclosure components clean in order to prevent dust and dirt from forming an unattractive film. The life of your cab components depend upon following these care procedures:

1. **NEVER USE AN ABRASIVE DETERGENT / VEHICLE CLEANER OR A WIRE BRISTLED BRUSH.** Do not use any **CITRUS BASED CLEANERS** such as orange or lemon.
2. Clean the enclosure surfaces thoroughly with warm soapy water and a COTTON cloth or chamois. Be sure to use mild soap, specifically a dish liquid or equivalent. Clean in a light circular motion for best results.
3. Remove grease and oil with mineral spirits and a COTTON cloth or chamois.

GENERAL INFORMATION

All installation procedures listed within this manual are generally representative of the machine model for which the manual is written. Your machine may be configured differently (e.g. SP1 vs. SP2, etc.), but the outline for the procedure should still be followed. For further support for any issues not covered within the pages of this manual, please contact Curtis Industries.

TOOLS REQUIRED:

Standard and Metric Wrenches
Standard and Metric Sockets
Torque Wrench
Allen Wrenches (T-Handle Recommended)
Razor Knife
Needle Nose Pliers
Grease
Measuring Tape
Silicone (black or clear)
Scissors
Snips
Electrical Tape
Drill
11/32" Drill Bit
Metal Cutting Saw (sawsall or cutoff wheel)
Teflon Tape

INSTALLATION

STEP 1: Vehicle Prep

- 1.1 Remove and save the Slow Moving Vehicle (SMV) sign and bracket (see Figure 1.1).
- 1.2 Unplug and remove the round directionals from the rear of the vehicle (see Figure 1.2).
- 1.3 Unplug and remove the optional work lights and brackets (if installed) from the ROPS at the rear of the vehicle (see Figure 1.3).
- 1.4 Remove and retain the front floor mat (see Figure 1.4). Upon reinstallation at a later step, the floor mat will need to be trimmed to fit around the cowl and several alignment knobs will need to be removed.
- 1.5 Remove the rear backhoe floor panel from the hinge pins and cut in line with the edge as shown in Figure 1.5. Use a paint marker to cover the cut edge and re-install.

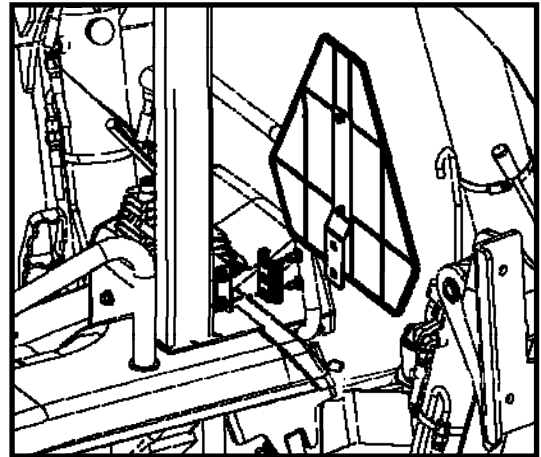

Figure 1.1: SMV Sign And Bracket

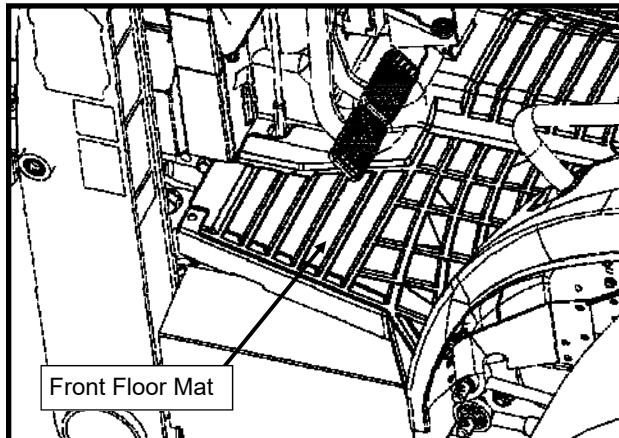

Figure 1.4: Remove the Front Floor Mat

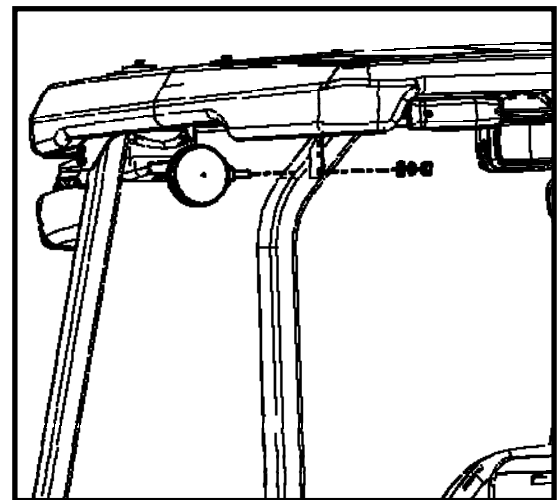

Figure 1.2: Remove Rear Round Work Lights

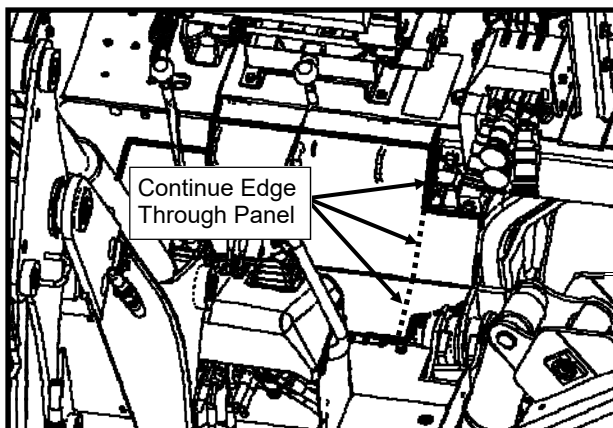

Figure 1.5: Trim Rear Floor Panel

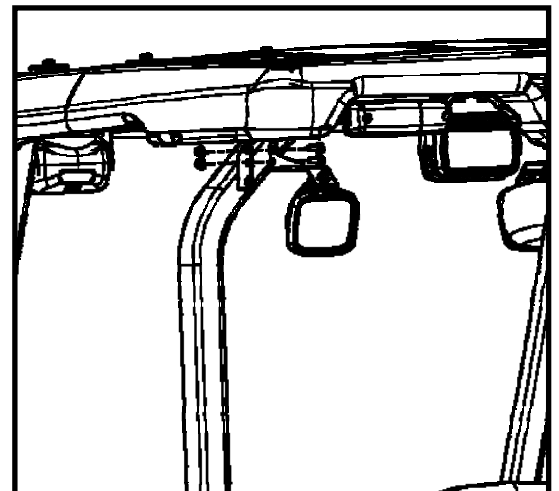

Figure 1.3: Remove Optional Rear Work Lights

INSTALLATION

STEP 1: Vehicle Prep Cont.

- 1.6 Remove the hydraulics cover that is located on the right side of the tractor beneath the floorboard. Mark out according to Figure 1.6 and cut as shown. Touch up the edge with a paint marker and re-install.
- 1.7 Remove the battery cover and save for re-use.

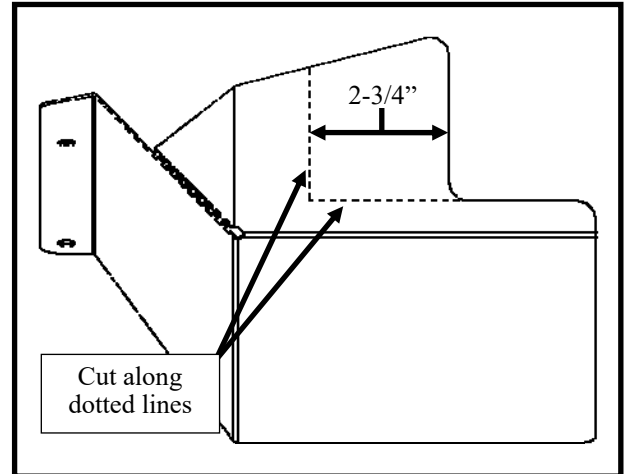

Figure 1.6: Right Hydraulic Cover

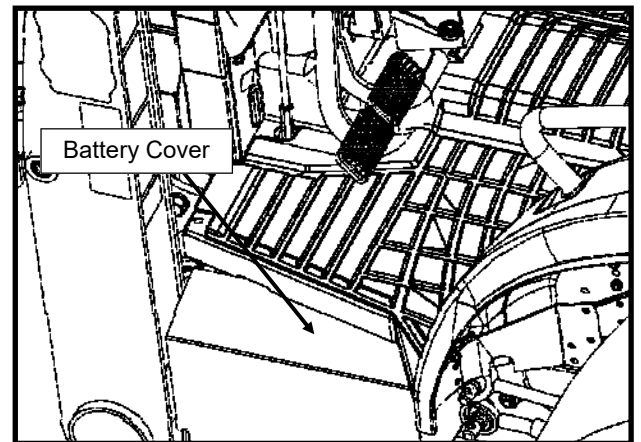

Figure 1.7: Remove Battery Cover

INSTALLATION

STEP 2: Cowl Assembly

- 2.1 Slide cowl over vehicle dash board (see Figure 2.1).
- 2.2 Fasten the bottom cowl flanges to the vehicle floor board (see Figure 2.2). Repeat on opposite side. Leave bolts loose.

Hardware Used

	<u>QTY</u>
5/16-18 x 3/4 Hex Head Flanged Cap Screw	2
5/16-18 Flanged Nylon Lock Nut	2

STEP 3: Windshield Support

- 3.1 Assemble the rear view mirror to the windshield support (see Figure 3.1).

Hardware Used

	<u>QTY</u>
#10-32 x 1/2 Pan Head Machine Screw	2
#10-32 Flanged Nylon Lock Nut	2

- 3.2 Remove and retain the rear M12 nut, lock washer, and flat washer from the upper front ROPS, just under the canopy (see Figure 3.2, canopy hidden for clarity). Push the end of the bolt flush with the OEM side frame bracket, but do not remove. Repeat for the other side.
- 3.3 With assistance, place the windshield support against the ROPS per Figure 3.2 and align the hole in the bracket on each side to the M12 ROPS bolt. Push the bolt through the bracket and secure with the flat washer, lock washer, and M12 nut removed in step 3.2. Leave loose.

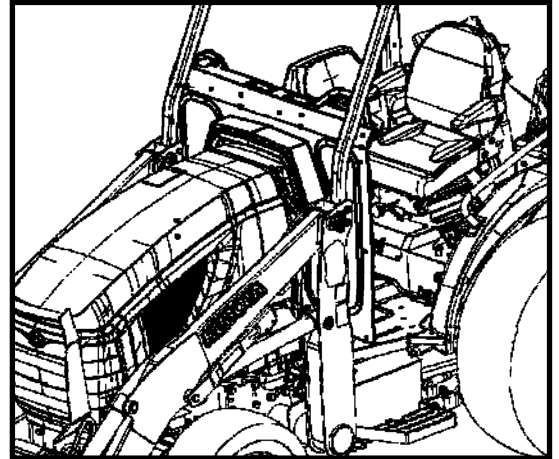

Figure 2.1: Slide On Cowl

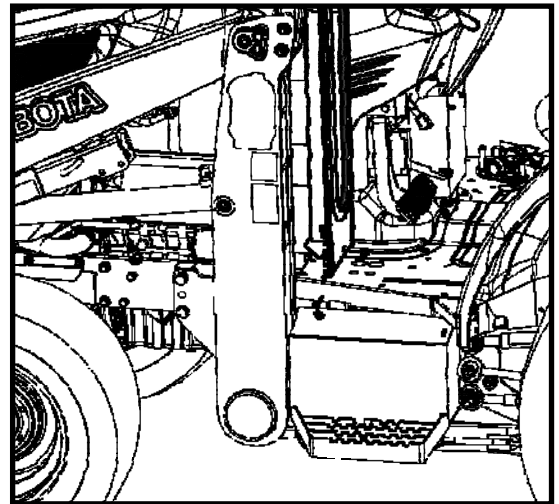

Figure 2.2: Fasten Cowl to Floor Board

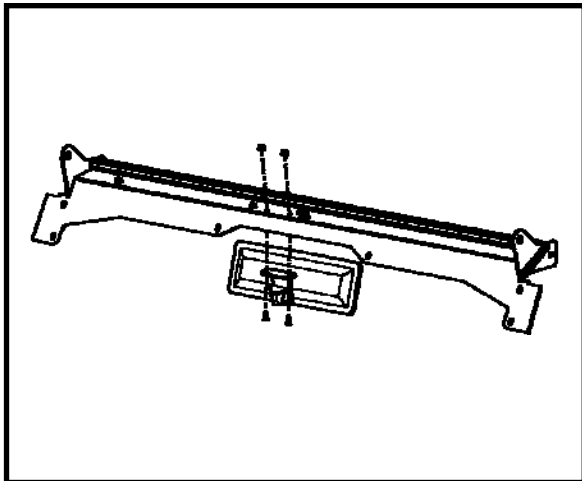

Figure 3.1: Assemble Mirror to Windshield Support

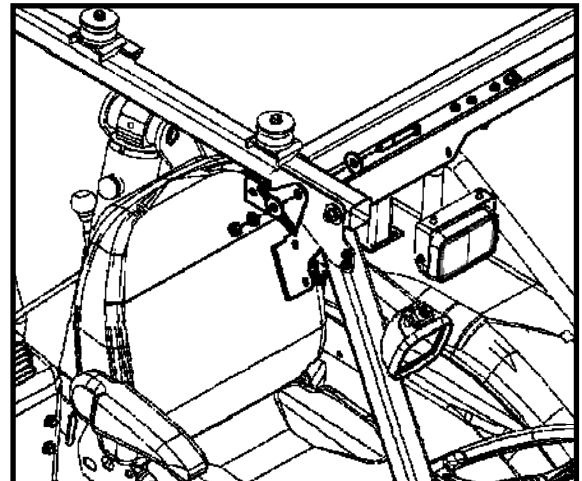

Figure 3.2: Fasten Windshield Support

INSTALLATION

STEP 4: Rear Panel

Note: If installing this cab on a tractor with optional rear remote hydraulics installed, Curtis kit 1KTLBL47HYD must be installed. Refer to Step 1 in the installation manual for the kit before installing the following rear panel otherwise there will be an interference.

- 4.1 Remove and retain the outer most M12 nut, lock washer, and flat washer from the upper front ROPS, just under the canopy (see Figure 4.1). Push the end of the bolt flush with the OEM side frame bracket, but do not remove. Repeat for the other side.
- 4.2 With assistance, place the rear panel against the ROPS per Figure 4.1 and push the M12 ROPS bolts through the holes in the rear panel. Secure with the flat washer, lock washer, and M12 nut removed in step 4.1. Leave loose.
- 4.3 Remove the bulb rubber trim on the right side of the rear panel to expose the u-shaped slot.
- 4.4 Slice the supplied rubber grommet and install around the vehicle wire harness
- 4.5 Install the grommet into the slot and re-install the bulb rubber trim from step 4.3. The grommet will deform when the rubber is re-installed.

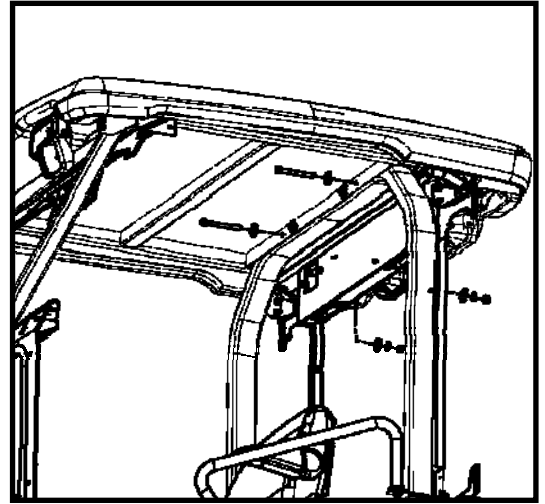

Figure 4.1: Fasten Rear Panel

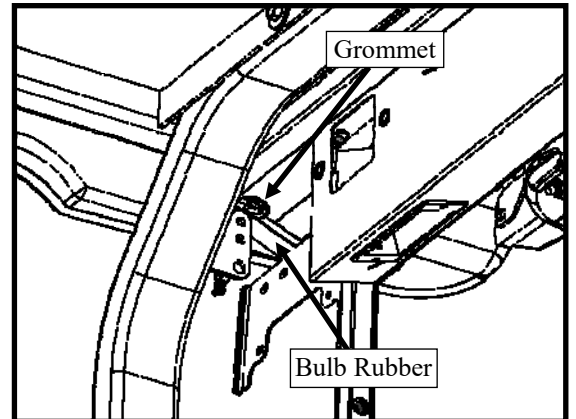

Figure 4.3: Install Grommet on Harness

STEP 5: Left Side Frame

- 5.1 Set a ROPS clamp in place on the left side ROPS tube with the larger flange towards the rear as shown in Figure 5.1.
- 5.2 Disconnect the gas shock at the top of the door and remove the door with assistance by unlatching at the front via the outer handle button or inside lever, and lift the door off the hinge pins. Remove the rear window by opening the latch, squeezing the buttons to release the latch and lifting the window off the hinge pins.
CAUTION: Be wary of the brass washer at each hinge pin. For best results, remove the washers and set them aside until the windows and doors are re-installed later.

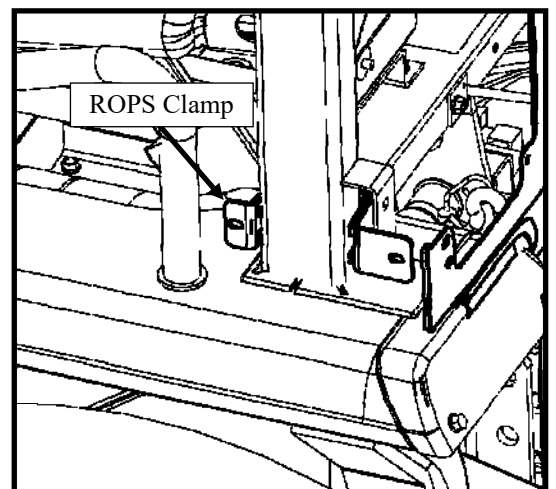

Figure 5.1: ROPS Clamp Set In Place

INSTALLATION

STEP 5: Left Side Frame Cont.

5.3 With assistance, set the left side frame up under the roof and onto the floor board and fasten the side frame to the windshield support (see Figure 5.3). Use the top hole on the front part of the windshield support, as the lower hole will be used with the windshield itself. Leave hardware loose.

Hardware Used

	<u>QTY</u>
5/16-18 x 3/4 Hex Head Flanged Cap Screw	2
5/16-18 Flanged Nylon Lock Nut	2

5.4 Install left upper rear mount (see Figure 5.4. Frame and rear panel are hidden). Leave hardware loose.

Hardware Used

	<u>QTY</u>
5/16-18 x 3/4 Hex Head Flanged Cap Screw	2

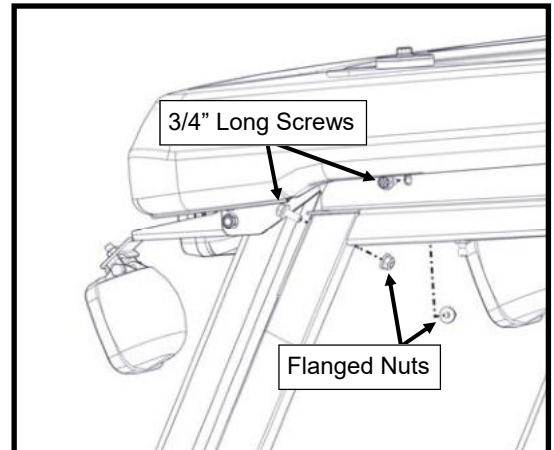

Figure 5.3: Side Frame to W/S Support Bolts

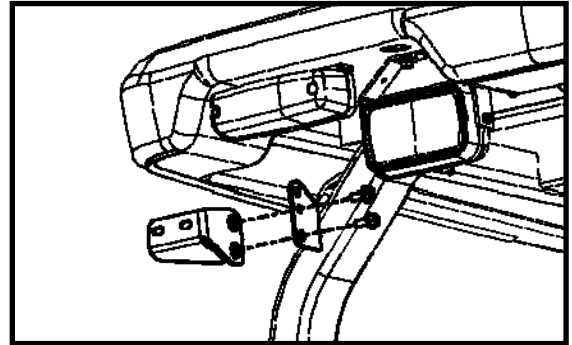

Figure 5.4: Upper Rear Mount

INSTALLATION

STEP 5: Left Side Frame Cont.

- 5.5 Install two 1" long bolts and two nuts through the rear panel, upper rear mount, and sideframe. (see Figure 5.5)
Leave hardware loose.

<u>Hardware Used</u>	<u>QTY</u>
5/16-18 x 1 Hex Head Flanged Cap Screw	2
5/16-18 Flanged Nylon Lock Nut	2

- 5.6 Install a 3/4" long bolt and nut at the bottom of the rear panel. Install in the uppermost hole. (see Figure 5.5)
Leave hardware loose.

<u>Hardware Used</u>	<u>QTY</u>
5/16-18 x 3/4 Hex Head Flanged Cap Screw	1
5/16-18 Flanged Nylon Lock Nut	1

- 5.7 Fasten the side frame to the floor board (see Figure 5.7).
Leave hardware loose.

<u>Hardware Used</u>	<u>QTY</u>
5/16-18 x 3/4 Button Head Socket Cap Screw	3
5/16-18 Flanged Nylon Lock Nut	3

- 5.8 Fasten the ROPS clamp to the side frame (see Fig. 5.8).
Leave hardware loose.

<u>Hardware Used</u>	<u>QTY</u>
5/16-18 x 1 Hex Head Flanged Cap Screw	2

- 5.9 Fasten the side frame to the cowl (see Figure 5.9). Leave hardware loose.

<u>Hardware Used</u>	<u>QTY</u>
5/16-18 x 3/4 Hex Head Flanged Cap Screw	5
5/16-18 Flanged Nylon Lock Nut	5

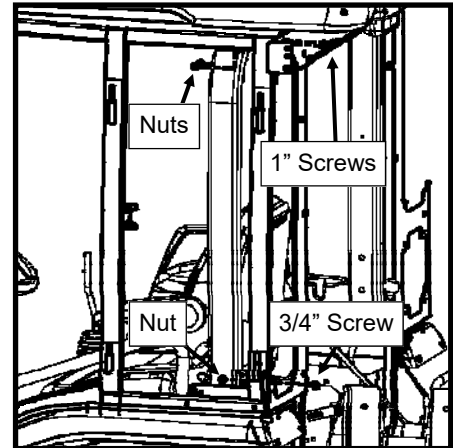

Figure 5.5: Side Frame to Rear Panel Bolts

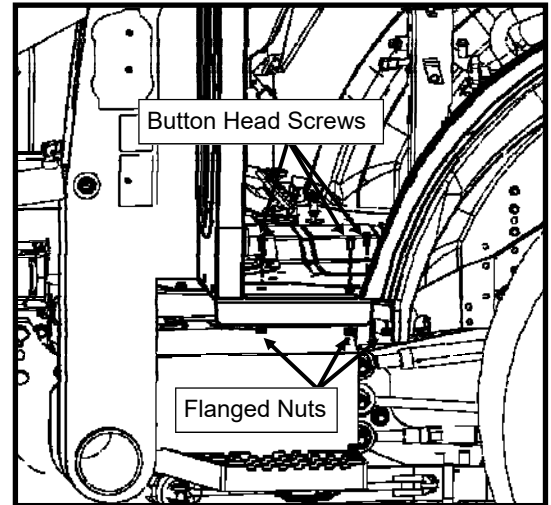

Figure 5.7: Side Frame to Floor Board Bolts

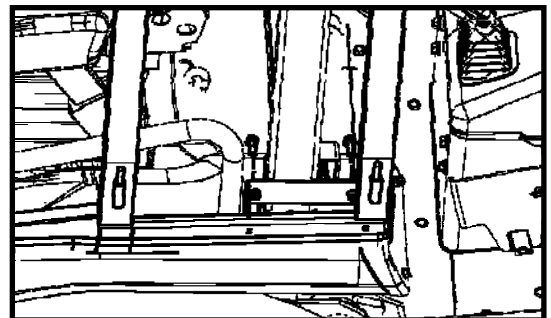

Figure 5.8: Side Frame ROPS Clamp

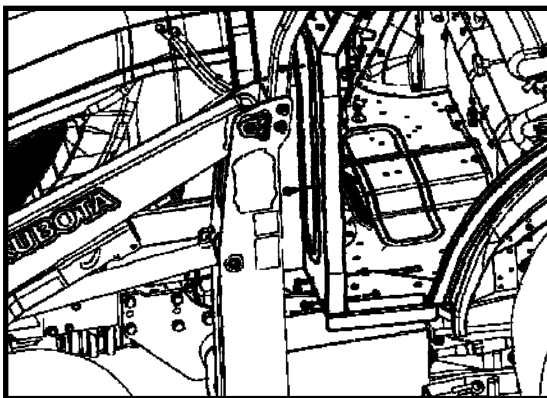

Figure 5.9: Side Frame to Cowl Bolts

INSTALLATION

STEP 6: Right Side Frame

6.1 Disconnect the gas shock at the top of the right door and remove the door with assistance by unlatching at the front via the outer handle button or inside lever, and lift the door off the hinge pins. Remove the rear window by opening the latch, squeezing the buttons to release the latch and lifting the window off the hinge pins.

CAUTION: Be wary of the brass washer at each hinge pin. For best results, remove the washers and set them aside until the windows and doors are re-installed later.

6.2 With assistance, set the side frame up under the roof and onto the floor board and fasten the side frame to the windshield support (see Figure 6.2). Use the top hole on the front part of the windshield support, as the lower hole will be used with the windshield itself. Leave hardware loose.

<u>Hardware Used</u>	<u>QTY</u>
5/16-18 x 3/4 Hex Head Flanged Cap Screw	1
5/16-18 Flanged Nylon Lock Nut	1

6.3 Install the upper rear mount opposite the one installed in step 5.4.

<u>Hardware Used</u>	<u>QTY</u>
5/16-18 x 3/4 Hex Head Flanged Cap Screw	2

6.4 Install two 1" long bolts and two nuts through the rear panel, upper mount, and sideframe. (see Figure 6.4). On the lower section of the rear panel, fasten the 3/4" long bolts and nuts, with the lower most bolt mirroring what was done on the left side frame. Leave hardware loose.

<u>Hardware Used</u>	<u>QTY</u>
5/16-18 x 3/4 Hex Head Flanged Cap Screw	2
5/16-18 x 1 Hex Head Flanged Cap Screw	2
5/16-18 Flanged Nylon Lock Nut	4

6.5 Fasten the side frame to the floor board (see Figure 6.5). Leave hardware loose.

<u>Hardware Used</u>	<u>QTY</u>
5/16-18 x 3/4 Button Head Socket Cap Screw	3
5/16-18 Flanged Nylon Lock Nut	3

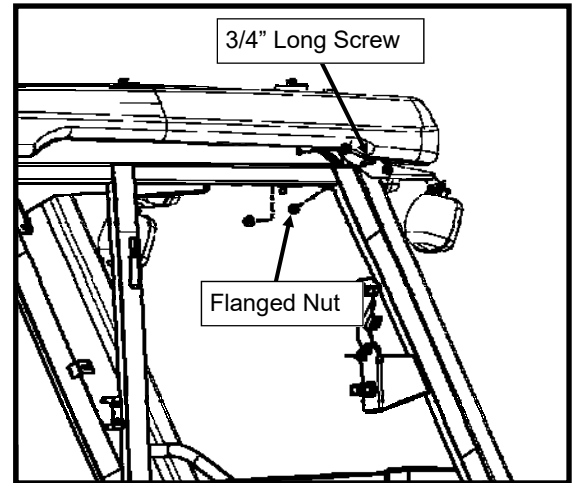

Figure 6.2: Side Frame to W/S Support Bolts

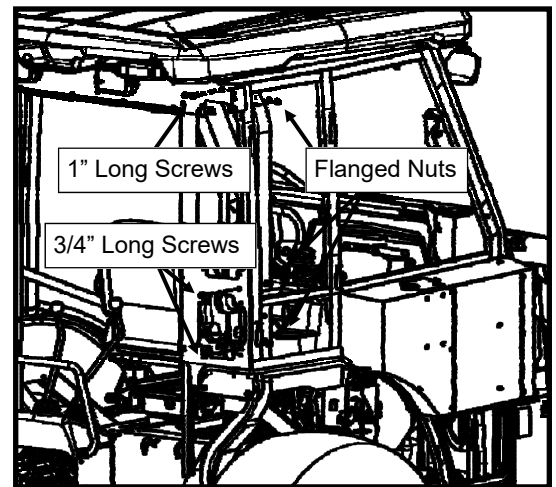

Figure 6.4: Side Frame to Rear Panel Bolts

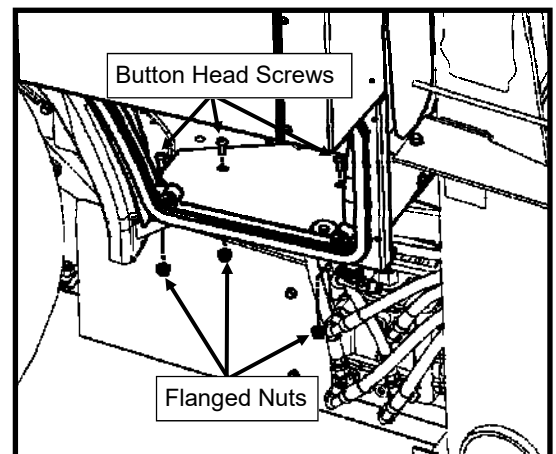

Figure 6.5: Side Frame to Floor Board Bolts

INSTALLATION

STEP 6: Right Side Frame Cont.

- 6.6 Fasten the ROPS clamp to the side frame (see Fig. 6.6). Leave hardware loose.

<u>Hardware Used</u>	<u>QTY</u>
5/16-18 x 1 Hex Head Flanged Cap Screw	2

- 6.7 Fasten the side frame to the side of the cowl (see Figure 6.7). Leave hardware loose.

<u>Hardware Used</u>	<u>QTY</u>
5/16-18 x 3/4 Hex Head Flanged Cap Screw	5

- 6.8 Fasten the side frame to the front of the cowl (see Fig. 6.8). Leave hardware loose.

<u>Hardware Used</u>	<u>QTY</u>
5/16-18 x 3/4 Hex Head Flanged Cap Screw	2
5/16-18 Flanged Nylon Lock Nut	2

- 6.9 Fasten the side frame to the cowl junction box (see Figure 6.9). Leave hardware loose.

<u>Hardware Used</u>	<u>QTY</u>
1/4-20 x 3/4 Button Head Socket Cap Screw	3

- 6.10 Connect the side frame wiring harness to the front wiper harness on the windshield support.

- 6.11 Route the washer hose through the p-clamps on the windshield support and connect to the fitting at the center of the windshield support. Use soap as a lubricant for easiest installation onto the barb.

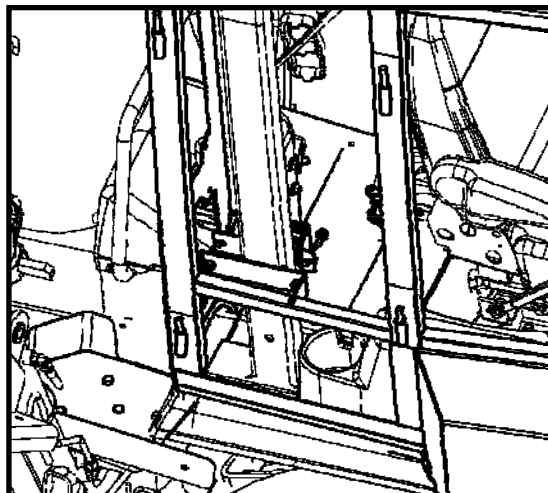

Figure 6.6: Side Frame ROPS Clamp

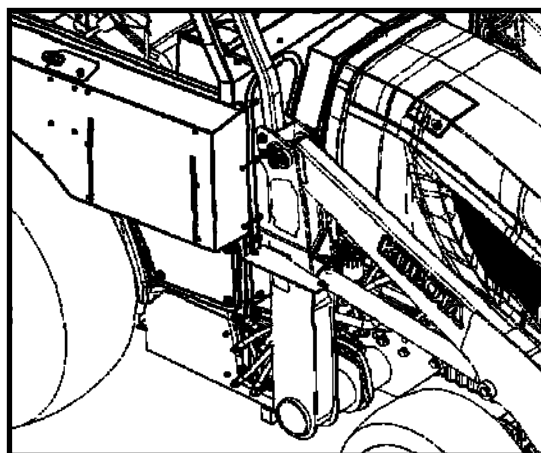

Figure 6.7: Side Frame to Cowl Bolts

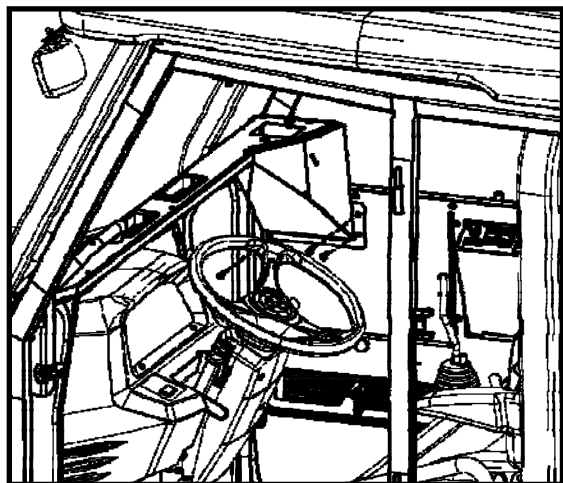

Figure 6.9: Side Frame Junction Block

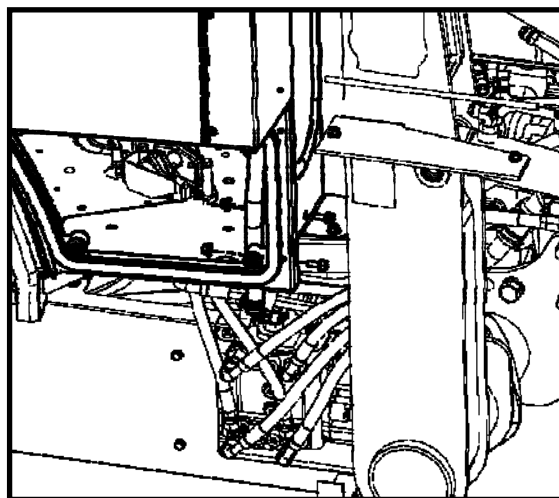

Figure 6.8: Side Frame to Cowl Bolts

INSTALLATION

STEP 7: Rear Corner Fillers

- 7.1 Remove the rearmost fender bolts (both left and right sides) and save for reuse.
- 7.2 Install the left rear corner filler to the vehicle (see Figures 7.1 and 7.2). Tighten the two 1/4-20 screws and leave the remaining hardware loose.

Hardware Used	QTY
1/4-20 x 3/4 Hex Head Flanged Cap Screw	2
#10-32 x 3/4 Truss Head Machine Screw	1
#10-32 Flanged Nylon Lock Nut	1
Fender Bolt and Nut	1

Note: Right rear corner filler will not fit with the optional rear remote hydraulics installed without modification. See the install manual for the 1KTLBL47HYD kit.

- 7.3 Fasten the right rear corner filler to the vehicle (see Figures 7.3a and 7.3b, right wheel hidden for clarity). Tighten the two 1/4-20 screws and leave the remaining hardware loose.

Hardware Used	QTY
1/4-20 x 3/4 Hex Head Flanged Cap Screw	2
1/4-20 x 5/8 Hex Head Flanged Cap Screw	1
1/4-20 Flanged Nylon Lock Nut	1
Fender Bolt and Nut	1

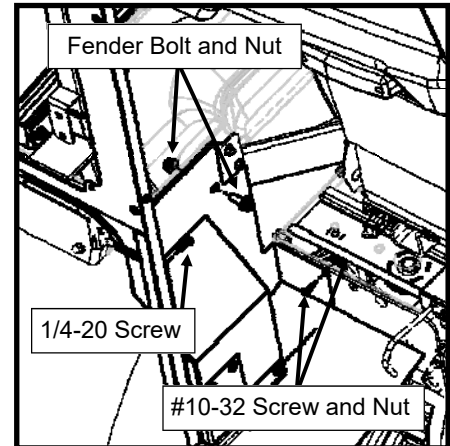

Figure 7.1: Left Rear Corner Filler

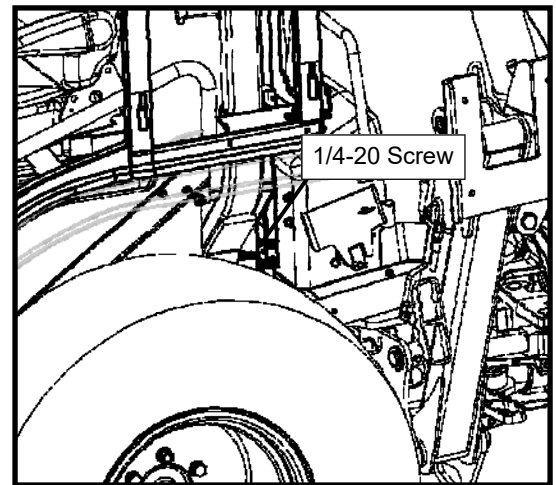

Figure 7.2: Left Rear Corner Filler

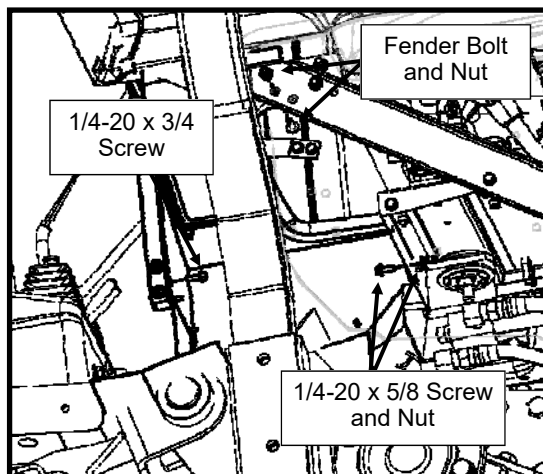

Figure 7.3a: Right Rear Corner Filler

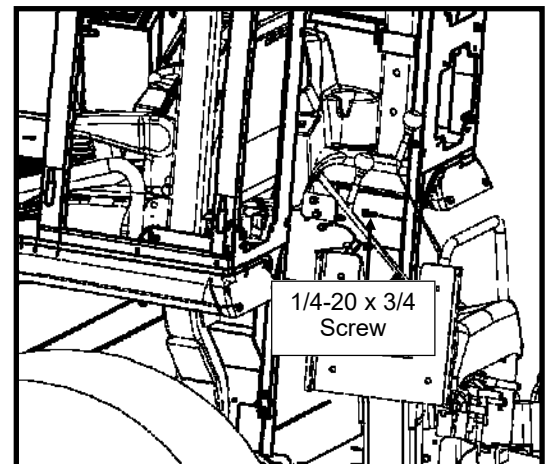

Figure 7.3b: Right Rear Corner Filler

INSTALLATION

STEP 8: Lower Rear Panel Brackets

8.1 Remove the bottom M14 bolt from the side of the ROPS tube and save for re-use.

Note: Do not remove both bolts at the same time as the ROPS may settle and is difficult to reposition.

8.2 Fasten the left lower rear panel bracket to the vehicle using the OEM bolt and sandwich a washer between the bracket and the ROPS (see Figure 8.1, wheel and backhoe hidden for clarity). Leave hardware loose.

Hardware Used

9/16 x 1-3/8 Flat Washer

QTY

2

8.3 Remove the upper M14 bolt from the side of the ROPS tube and re-fasten through the remaining hole in the bracket. A 9/16 ID washer should be sandwiched between the bracket and the ROPS. Note: Tape may be used to aid in installation of the washer.

Hardware Used

5/16-18 x 3/4 Hex Head Flanged Cap Screw

QTY

4

8.4 Repeat steps 8.1 through 8.3 on right hand side.

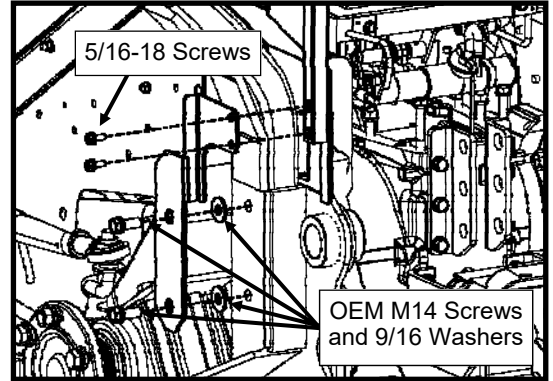

Figure 8.1: Left Lower Rear Panel Bracket

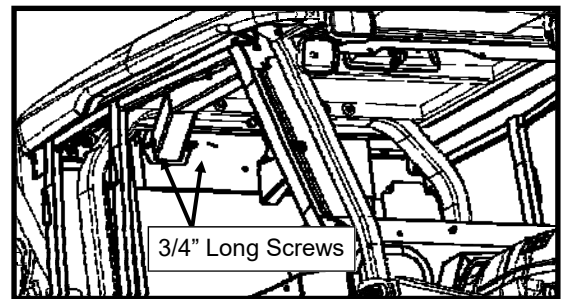

Figure 9.1: Heater Duct Rear Bolts

STEP 9: Heater Duct

9.1 Fasten the rear of the heater duct to the rear panel (see Figure 9.1). Leave hardware loose.

Hardware Used

5/16-18 x 3/4 Hex Head Cap Screw

QTY

2

9.2 Fasten the front of the heater duct to the cowl (see Figure 9.2). Leave hardware loose.

Hardware Used

5/16-18 x 3/4 Hex Head Cap Screw

QTY

2

9.3 Fasten the corner of the heater duct to sideframe (see Figure 9.3). Leave hardware loose.

Hardware Used

5/16-18 x 3/4 Hex Head Cap Screw

QTY

1

5/16-18 Flanged Nylon Lock Nut

1

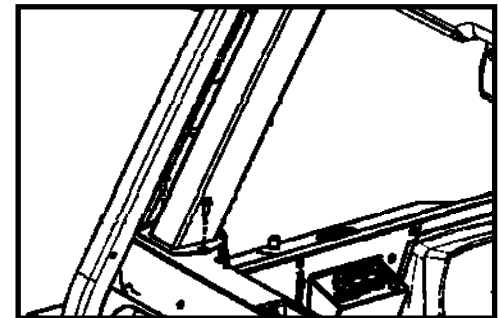

Figure 9.2: Heater Duct

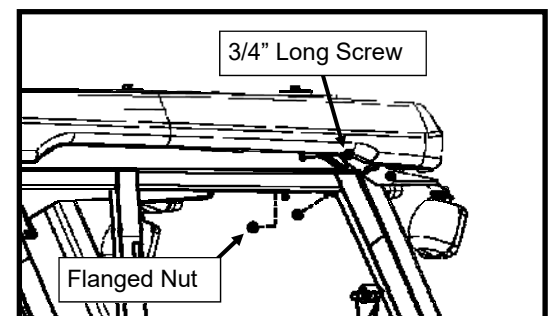

Figure 9.3: Side Frame Bolt

INSTALLATION

STEP 10: Tighten all bolts

10.1 Torque all 5/16-18 bolts to 19 ft-lbs. (25.8 N-m) in the following order:

- 1) Qty 3: windshield support to side frames.
- 2) Qty 4: ROPS brackets to side frames.
- 3) Qty 6: cab floorboards to tractor floor pan.
- 4) Qty 4: upper rear mounts to ROPS.
- 5) Qty 7: rear panel to upper rear mounts and sideframes.
- 6) Qty 12: cowl to side frames.
- 7) Qty 5: heater duct to cowl, rear panel, sideframe
- 8) Qty 2: cowl to tractor floor pan
- 9) Qty 2: tractor fender bolts (1L and 1R)
- 10) Qty 4: lower rear panel brackets (2L and 2R)

10.2 Torque (3) 1/4-20 bolts from the junction block to the right side frame to 10 ft-lbs. (13.5 N-m).

10.3 Torque the (2) M12 ROPS bolts and nuts at the windshield support to 62 ft-lbs. (84 N-m).

10.4 Torque the (2) M12 ROPS bolts and nuts at the top of the rear panel to 62 ft-lbs. (84 N-m).

10.5 Torque the (4) M14 ROPS bolts for the lower rear panel brackets to 87 ft-lbs. (118 N-m).

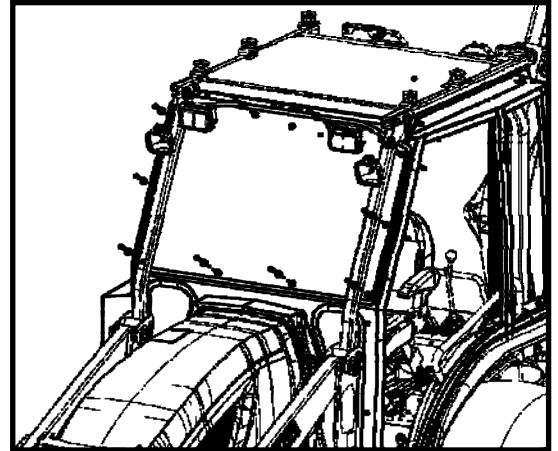

Figure 11.1: Windshield

STEP 11: Windshield

11.1 Place the windshield onto the front of the side frames and secure it with (10) 1/4-20 x 1-1/2" flanged hex bolts and fender washers outside, and flanged nuts inside. Tighten until there are no visible gaps between the windshield rubber and frame (see Figure 11.1, roof hidden for clarity).

Hardware Used

	<u>QTY</u>
1/4-20 x 1-1/2 Hex Head Flanged Cap Screw	10
1/4 Fender Washer	10
1/4-20 Flanged Nylon Lock Nut	6

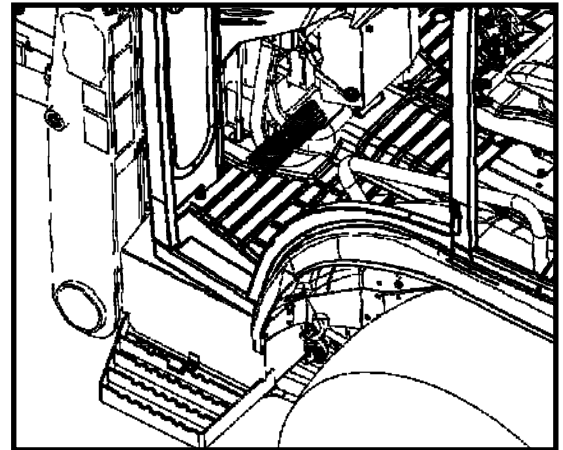

Figure 12.1: Trim Floor Mat to Fit

STEP 12: Floor Mat

12.1 Re-install floor mat and trim to fit. Three alignment nubs on each side will have to be cut off where the three button head bolts secure the side frames to the floor board. The front corners will also need to be trimmed to fit around the cowl. (See Figure 12.1)

STEP 13: Electrical Harness Install

13.1 Locate the supplied power wire harness. Modify the harness to move the purple wire over to the ring terminal end of the harness. Connect ring terminal on the red wire to the positive (+) battery terminal.

13.2 Connect ring terminal on the black wire to the negative (-) battery terminal.

13.3 Locate the tractor ignition source on the main harness just inside the battery. The connector is a female bullet terminal wrapped in blue electrical tape.

13.4 Connect the male bullet terminal on the purple wire on the harness to the tractor ignition source.

13.5 Route the cab connector end of the wire harness under the floor of the tractor to the front of the right sideframe and connect to the wire extending from the right frame.

13.6 Turn the ignition to on and check to see that the switches illuminate and the fan functions.

13.7 Secure the harness to the tractor using supplied cable ties.

13.8 Replace the battery cover.

INSTALLATION

STEP 14: Windshield Wiper

- 14.1 Remove the large hex nut, plastic washer, and rubber washer from the motor shaft making sure to leave the black plastic standoff on the motor shaft. Put the large white nylon bushing with the collar over the shaft as shown in Fig.14.1.
- 14.2 From the inside, insert the motor shaft out through the larger hole in the windshield until the white nylon bushing is against the windshield. Replace the rubber washer, plastic washer, and hex nut on the outside end of the shaft. Do not tighten completely at this point. **CAUTION: Make sure that the metal parts of the wiper motor do not contact the glass during installation. Damage could occur.**
- 14.3 From the inside, put the small white nylon bushing with the collar into the small hole in the windshield and pivot the wiper motor so that the small hole aligns with the hole in the bushing. Insert the 1/4-20 bolt through the internal tooth washer, the hole in the wiper motor bracket, the small bushing, and finally the windshield. Next install the rubber washer, plastic washer, and cap nut.
- 14.4 Tighten the bolts at this time. Tighten the hex nut on the motor shaft to 30 inch-lbs and the 1/4-20 hex head bolt to 75 inch-lbs. **WARNING: Over tightening wiper mounting hardware can damage windshield and components.**
- 14.5 Connect the wiper motor to the harness on the windshield support

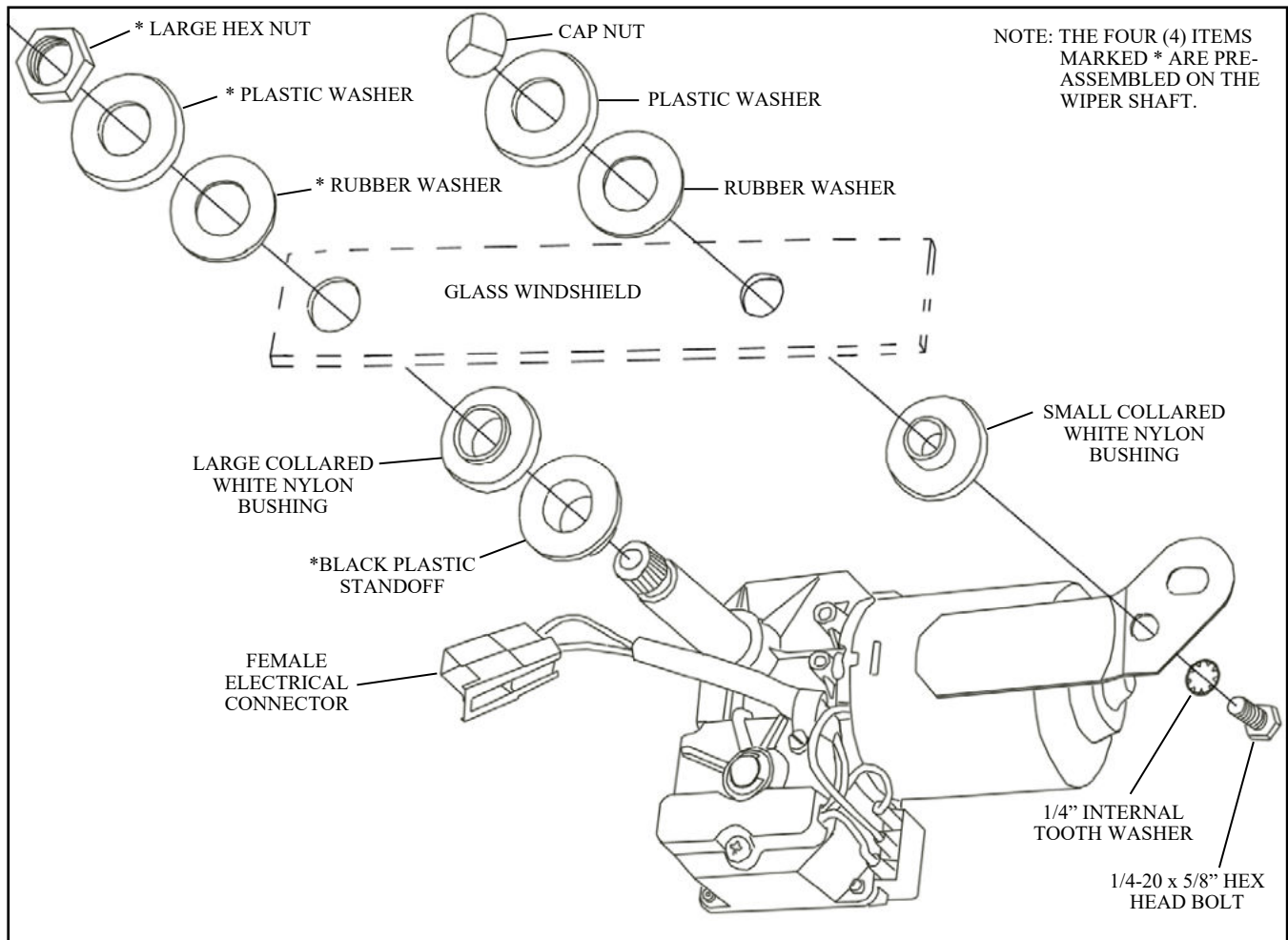

Figure 14.1: Wiper Motor Installation

INSTALLATION

STEP 15: Windshield Wiper Blade

- 15.1 Connect the windshield wiper blade and arm together.
 - 15.2 Lift the locking tab on the underside of the wiper arm and extend the wiper arm to the desired length. The angle of the blade can be adjusted by loosening the small bolt on the top of the wiper arm.
 - 15.3 Press the wiper arm onto the shaft so that it is positioned at the eight (8) o'clock position when looked at from outside the cab. Turn the ignition on and turn the wiper motor on and test its operation. Adjust the arm sweep by turning the blade, adjusting the arm length, or removing the wiper arm off of the motor shaft and reinstalling it at a different position.
 - 15.4 Make sure wiper arm is fully seated on wiper motor shaft so that the "L" shaped spring clip is locked under the splines as seen in figure 15.4.
 - 15.5 Once wiper is fully adjusted, tighten the set screw on the wiper arm. The set screw location is noted in illustration at location A
Note: a mirror was used in order to clearly see and confirm the spring clip engagement. It may be necessary to lightly tap the arm with a rubber mallet to fully seat the arm.
- CAUTION:** to avoid breaking the windshield, support the wiper motor with your hand when tapping the arm. Wear safety glasses!
- 15.6 Connect the rubber hose on the wiper arm to the fitting that is preinstalled on the windshield support. It is recommended to use soap as a lubricant for easiest installation onto the barb.
 - 15.7 Push any additional wire or hose back into the tube.

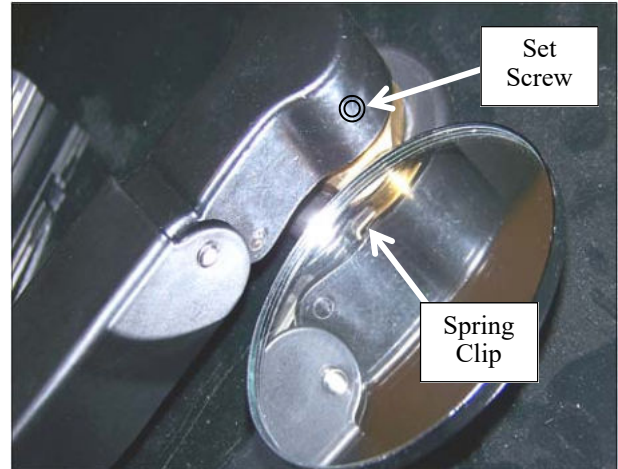

Figure 15.4: Wiper Arm Installation

INSTALLATION

STEP 16: Rear Panel Windows

Note: if installing with the optional rear remote hydraulics, the small lower right window will not be installed. See install manual provided with 1KTLBL47HYD for more details.

- 16.1 Attach each of the three rear windows to the rear panel in the same manner as the windshield (see Figure 16.1). Use the 1-1/2" screws in the four corners where indicated by the "A"

Hardware Used

	<u>QTY</u>
1/4-20 x 1-1/2 Hex Head Flanged Cap Screw	4
1/4-20 x 1-1/4 Hex Head Flanged Cap Screw	8
1/4 Fender Washer	12
1/4-20 Flanged Nylon Lock Nut	12

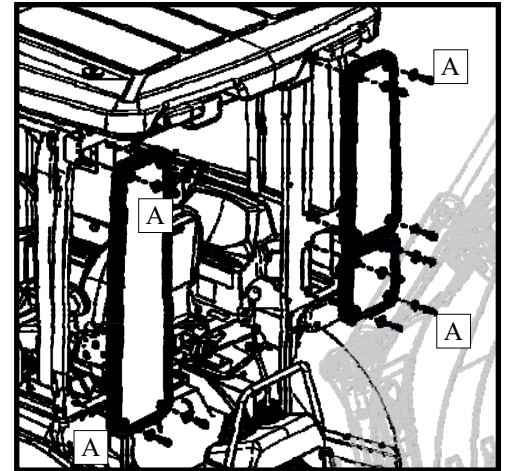

Figure 16.1: Rear Panel Windows

STEP 17: Doors and Windows

- 17.1 Apply grease to each of the four pins on each side frame (a total of eight pins). Ensure that each pin has one brass washer installed.
- 17.2 Hang each rear window onto the rear pins on each side frame and connect the latch at the front of each window.
- 17.3 Hang each door onto the forward pins on each side frame. Open the door to slightly and attach a gas shock onto the ball studs on the door and frame, with the quick-release end on the frame. (See Figures 17.3a and 17.3b)

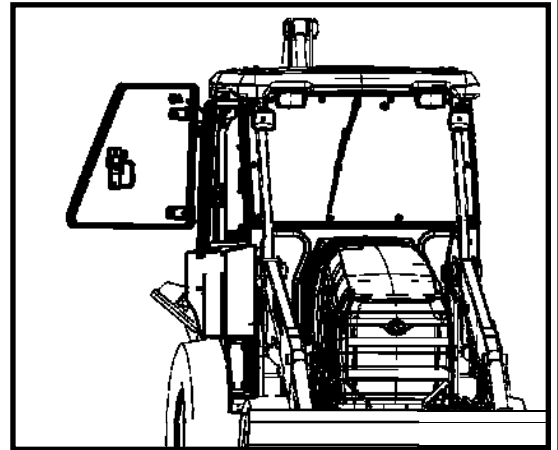

Figure 17.3a: Right Door

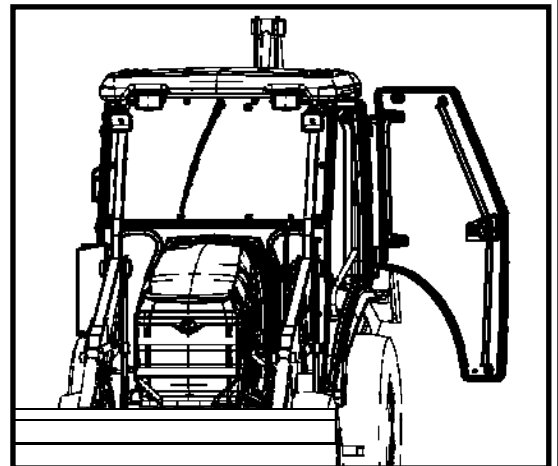

Figure 17.3b: Left Door

INSTALLATION

STEP 18: Backhoe Cab

18.1 Fasten the backhoe cab footers to the backhoe floor board sides (see Figure 18.1, outriggers hidden for clarity). Place the 3/8 fender washer over the shoulder screw, then sandwich the 5/16 fender washer between the backhoe cab footers and the backhoe floor board sides. The new footers should then be able to float a little side to side. Tighten hardware.

Hardware Used

3/8 x 1/4 Socket Head Shoulder Screw	4
3/8 x 1-1/4 Fender Washer	4
5/16 x 1 Fender Washer	4
5/16-18 Flanged Nylon Lock Nut	4

QTY

- 18.2 Attach the supplied velcro to the backhoe as shown in Figure 18.2. Be sure to clean the surfaces properly before installation. Note: the upper Velcro strip should go on the inside of the black plastic cover along the bottom edge of the plastic. The vinyl panel can be used as a guide.
- 18.3 Attach another section of the supplied velcro to the backhoe cab as shown in Figure 18.3.
- 18.4 With assistance, place the backhoe cab on to the backhoe cab footers (see Figure 18.4, outriggers hidden for clarity).

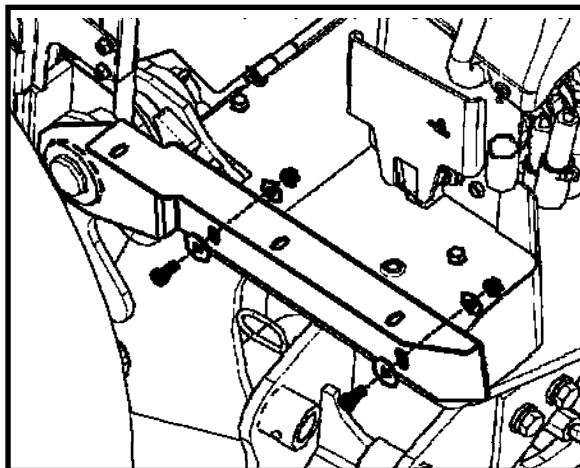

Figure 18.1: Backhoe Cab Footers

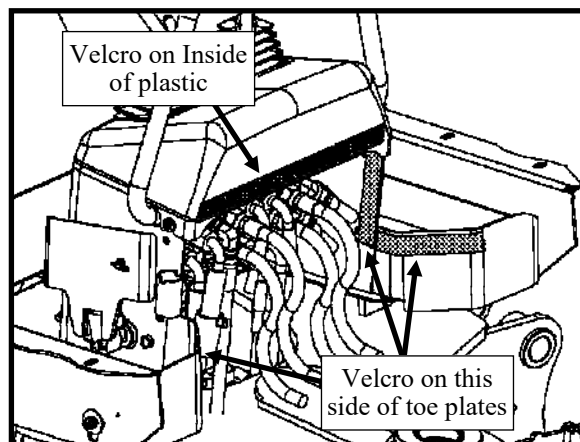

Figure 18.2: Attach Velcro to Backhoe

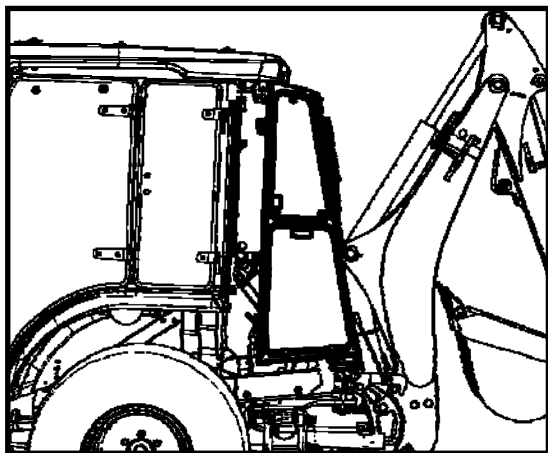

Figure 18.4: Drop On Backhoe Cab

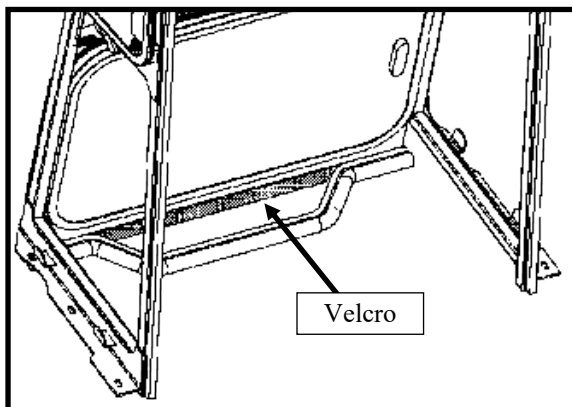

Figure 18.3: Attach Velcro to Backhoe Cab

INSTALLATION

STEP 18: Backhoe Cab Cont.

- 18.5 Fasten the backhoe cab to the backhoe cab footers, but be sure to leave the bolts loose (see Figure 18.5, outriggers hidden for clarity).

Hardware Used	QTY
5/16-18 x 1 Hex Head Flanged Cap Screw	6
5/16 Flat Washer	6
5/16-18 Flanged Nylon Lock Nut	6

- 18.6 Fasten the backhoe cab adjustable handle cables to the backhoe cab (see Figure 18.6)

Hardware Used	QTY
#10-32 x 1/2 Philips Head Machine Screw	2
#10-32 Flanged Nylon Lock Nut	2

- 18.7 Rotate the backhoe cab forward and secure backhoe cab to the rear panel with the adjustable handles (see Figure 18.7). Note: An additional clamp can be used in order to compress the foam seal and allow the slot and threaded insert to align for easier hand screw installation.
- 18.8 Adjust the lower portion of the backhoe cab so that there is an even crush on the foam seal against the rear panel and then tighten the bolts securing the cab to the footer plates.
- 18.9 Install the supplied vinyl closeout panel on the rear side of the backhoe controls.
- 18.10 Install backhoe cab side windows (see Figure 18.10).
- 18.11 Connect the wiring for the wiper harness and check to make sure wiper functions properly.
- 18.12 Install the supplied rubber floor mat onto the backhoe floorboards. Be sure to push the mat under the side fillers for best seal.

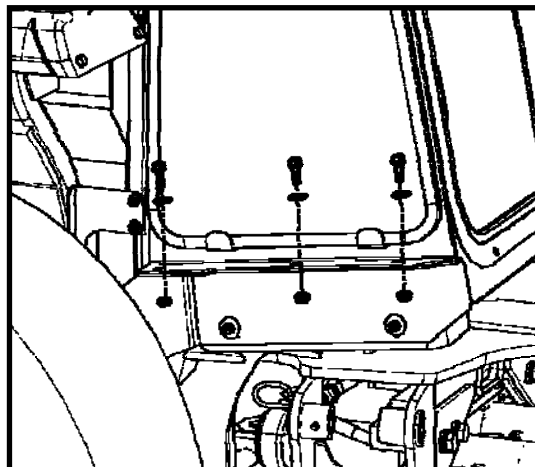

Figure 18.5: Fasten Backhoe Cab

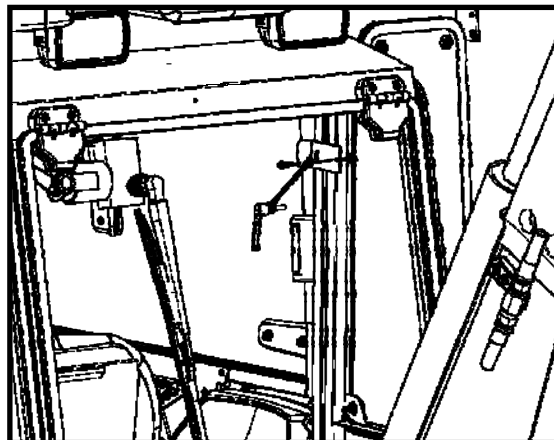

Figure 18.6: Backhoe Cab Handle Cables

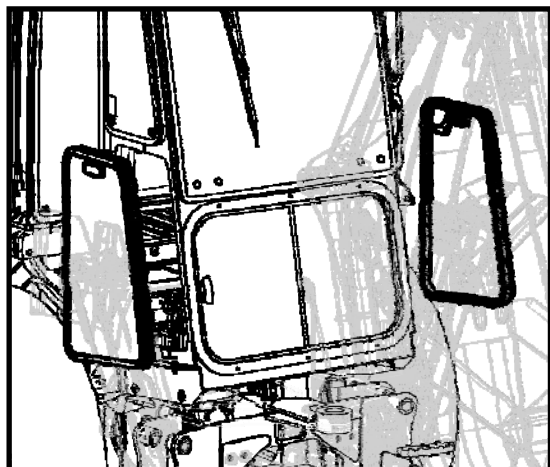

Figure 18.10: Backhoe Cab Side Windows

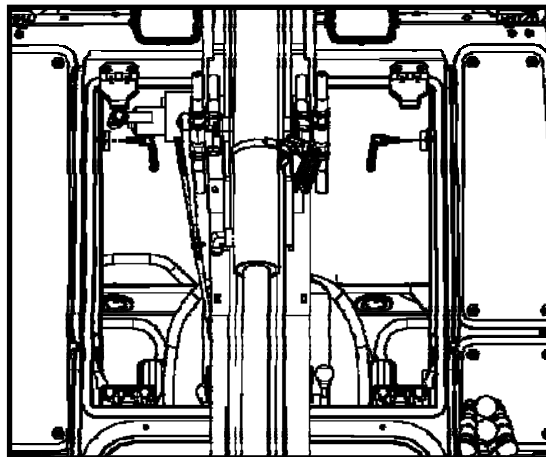

Figure 18.7: Secure Backhoe Cab Handles

INSTALLATION

STEP 19: Heater Hose Install

- 19.1 Raise the front loader bucket up and set the cylinder safety lock.
- 19.2 Install corrugated split-loom onto heater hoses.
- 19.3 With engine cold, open the hood, remove engine side shrouds, and drain the coolant from the radiator.
- 19.4 Remove plug and insert the supplied 90° fitting shown in Figure 19.4 into left engine tie in (supply). Use pipe thread sealant. Rotate the fitting so that the hose barb is aiming towards the rear of the tractor.
- 19.5 Remove the two bolts holding the guard in place on the right side of the motor and remove the guard as shown in Figure 19.5. Save for re-use.
- 19.6 Remove the two bolts holding the black reserve tank and save for reuse as shown in Figure 19.6.
- 19.7 Remove the 90 degree air hose shown in Figure 19.6.
- 19.8 Remove the three bolts securing the fuel filter mounting bracket and save for reuse as shown in Figure 19.8. Pivot the fuel filter out of the way to access the plug on the side of the water pump.

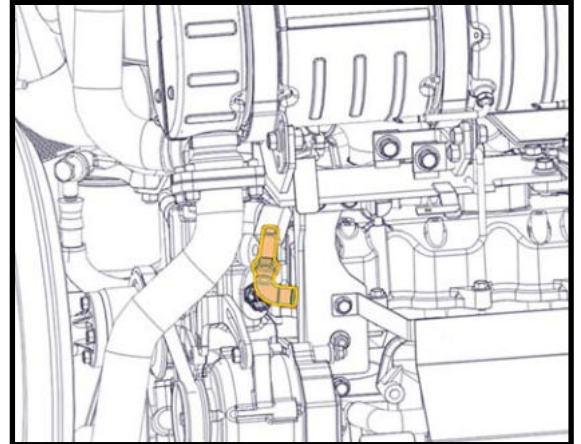

Figure 19.4 Heater Supply Fitting

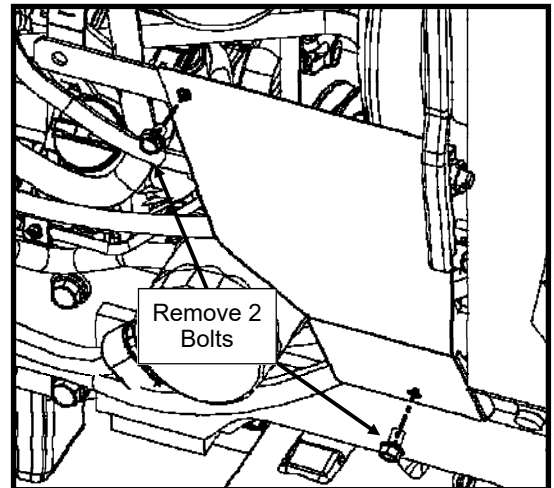

Figure 19.5 Remove Guard

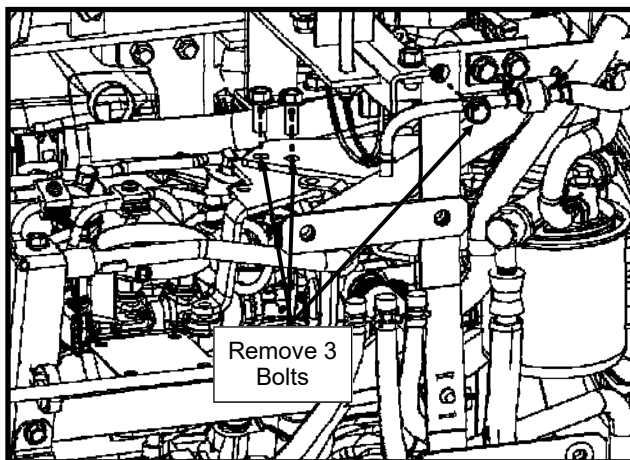

Figure 19.8 Remove Filter Mounting Bracket

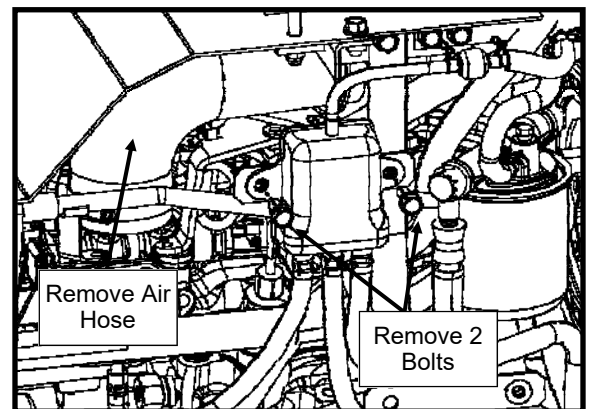

Figure 19.6 Heater Hose Connection

INSTALLATION

STEP 19: Heater Hose Install

- 19.9 Remove plug from the water pump and insert straight fitting (from cab hardware kit) shown in Figure 19.9 into right engine tie in (return). Use pipe thread sealant.
- 19.10 Use hose clamps to fasten heater hoses to both left and right fittings.
- 19.11 Route hoses back along the sides of the motor and over to the bottom of the right side frame. Be sure to avoid all moving and hot components.
- 19.12 Reconnect fuel filter mount, the air hose, black reserve tank, and the guard removed in steps 19.5, 19.6, 19.7, and 19.8.
- 19.13 With hoses properly routed so there are no kinks, cut to the appropriate length and connect to the elbows under the right floorboard using hose clamps. See Figure 19.13. Note: the elbows can be rotated to achieve ideal routing.
- 19.14 Re-fill coolant system.
- 19.15 Turn engine on and check for leaks.
- 19.16 Check to make sure heater hoses get warm.
- 19.17 Allow engine to cool completely and top off coolant.

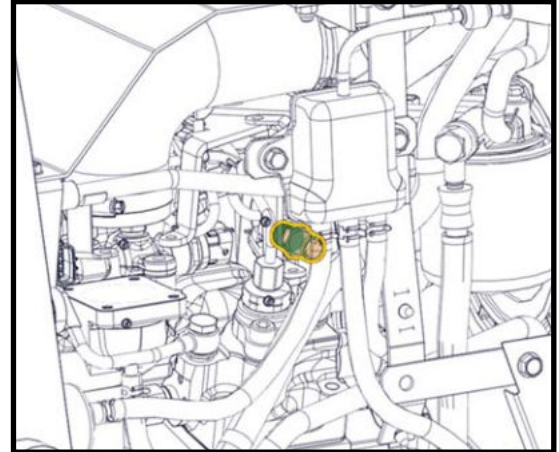

Figure 19.9 Heater Return Fitting

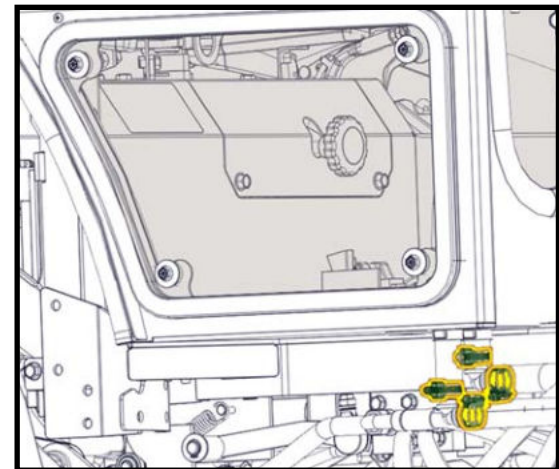

Figure 19.13 Connect Elbow Fittings

STEP 20: Miscellaneous

- 20.1 Fill washer bottle through exterior cover plate on right side frame.
- 20.2 Re-install the SMV sign onto the tab at the bottom of the left sideframe.
- 20.3 Re-install the directional to the tabs on the outside of the sideframes. Connect the supplied 8" extension harness to the light and connect the open end to the main tractor harness.
- 20.4 If the tractor had optional rear work lights installed, re-install on the tabs on the outside of the sideframes.
- 20.5 Secure any extra wiring that may be dangling.

OPERATION

Console Controls

NOTES:

- Standard switches for Windshield Fluid and Heater Fan are located on the right side frame console.
- All cab accessories are active only when the tractor ignition key is set to ACC or ON. All switches will be lit when power is available to the switch.
- If an individual switch fails to light, it may be an indication of a tripped circuit breaker.

1. To operate the wipers, actuate the switch on the wiper motor body as shown in Figure 1.
2. Turn heater control knob clockwise to increase the air temperature. See Figure 2.
3. Actuate the blower switch to choose either high or low speed.
4. Press and hold washer fluid switch to spray the windshield. *Tip - Adjust washer nozzles with a needle for best spray
5. See Figure 2 for circuit breaker location. If the breaker is tripped, the white button will pop out. To reset simply push the button back in.

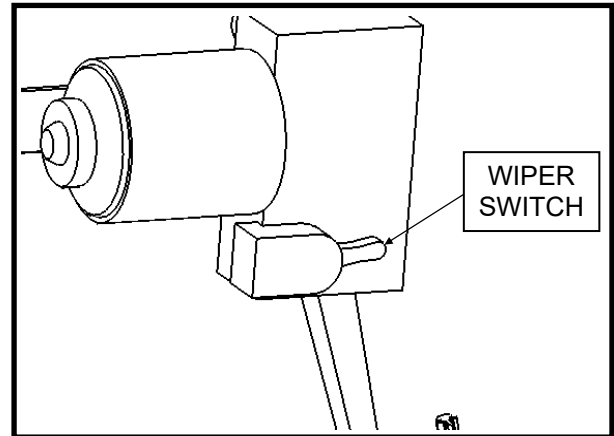

Figure 1: Wiper Power Switch

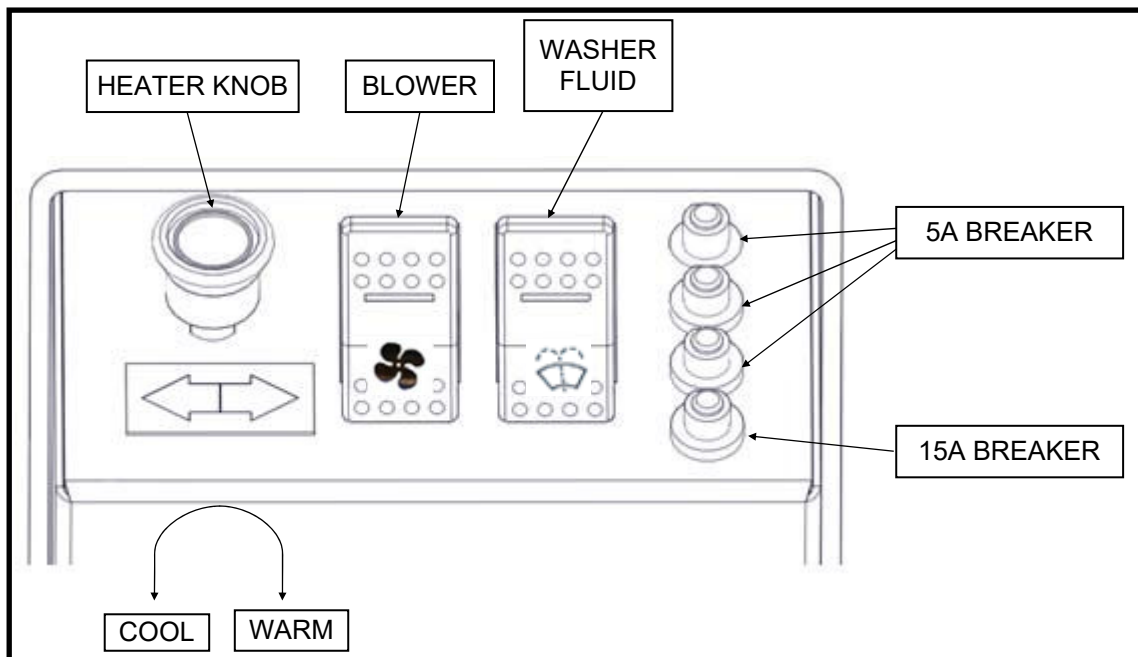

Figure 2: Console Controls

OPERATION

Air Circulation

1. For fresh air intake, unpin and pull baffle control arm down to block interior vents as shown in Figure 1.
2. To recycle cabin air, unpin and push baffle control arm in to block exterior vents as shown in Figure 2.

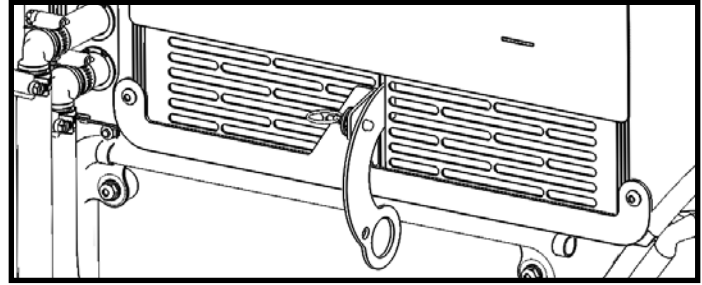

Figure 1. Exterior Air

Air Filter

1. To change the air filter, unscrew the thumb screw shown in Figure 3. Remove drawer from side frame.
2. Remove the two thumb screws which secure the air filter. Replace air filter with NAPA # FIL4752. See Figure 4.

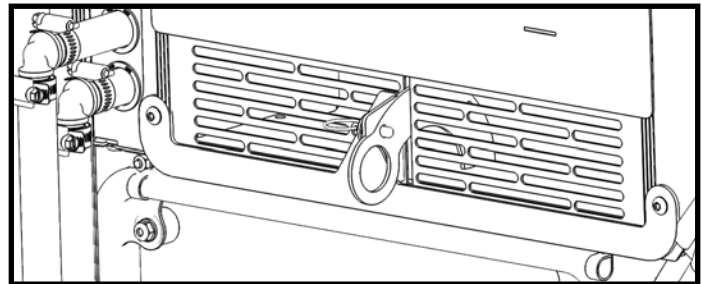

Figure 2. Interior Air

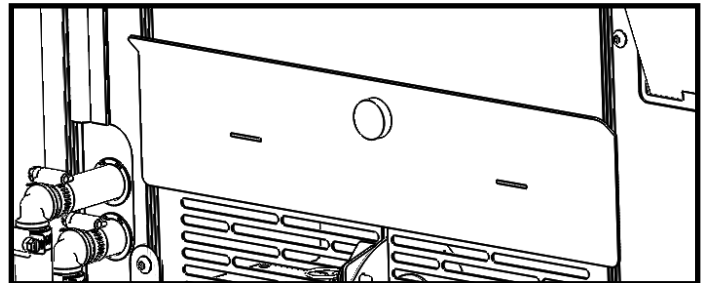

Figure 3. Air Filter Tray Removal

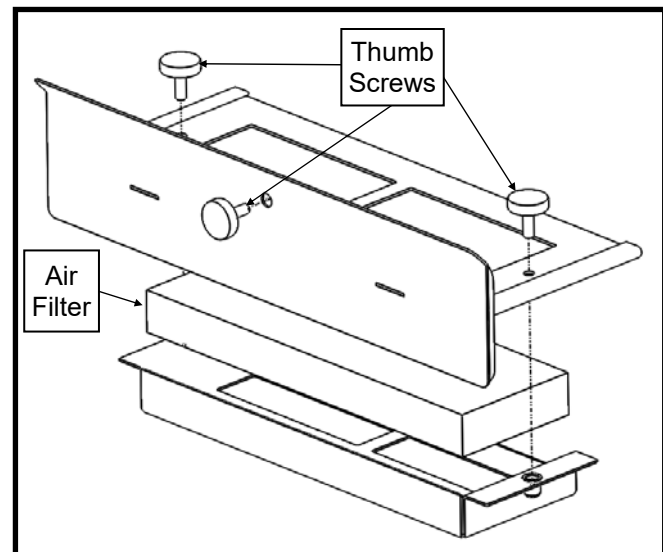

Figure 4. Air Filter Tray Assembly

OPERATION

Door Removal and Installation:

- Open the door to its widest extent allowed by the gas shock. Press the orange button on the end of the gas shock attached to the frame to remove that end from the ball stud.
- Lift the door from the pins on the rear leg of the side frame.
- Remove and retain the brass washers from the pins (one washer per pin).
- To install: Apply grease (not supplied) to the pins, install one (1) brass washer onto each pin and drop the door onto the pins. NOTE: one hinge pin is longer to aid in installation.
- Doors can be adjusted for better fit/operation using the bolts for the hinges, striker bolt up down and the door latch forward/back.

Side Window Removal and Installation:

- Open the Pop-out Latch on the rear window.
- Press the two buttons on the latch arm to release the latch from the side frame.
- Standing at the left of the tractor/cab and firmly holding the rear window, swing the rear window to the left and lift the window off of the pins.
- To install: Apply grease (not supplied) to the pins, install one (1) brass washer onto each pin and drop the rear window onto the pins. Insert the pins from the Pop-out Latch arm into the mount on the rear panel and ensure that both pins are extended into the mount.

OPERATION

Removing the Backhoe

CAUTION

To avoid personal injury:

- When starting the engine, always sit in the tractor operator's seat.
- When getting off the tractor, make sure that PTO lever is off and range gear shift lever is in neutral. Then set the parking brake.
- Keep hands, feet and body from between tractor and backhoe. Never allow any part of body under the machine.
- When leaving the backhoe operator's seat, fully lower the boom to the ground.
- When removing the backhoe set the swing lock pin.

IMPORTANT:

- When removing the backhoe, set the engine speed low idle.
 - For removing the backhoe, locate the tractor / loader backhoe on a flat level and hard surface, preferably concrete.
 - If the surface is soft, place a board on the ground for the bucket and stabilizers.
1. Remove both hand screws from backhoe cab.
 2. Set the swing lock pin to prevent the pivoting of the boom before removing the backhoe.

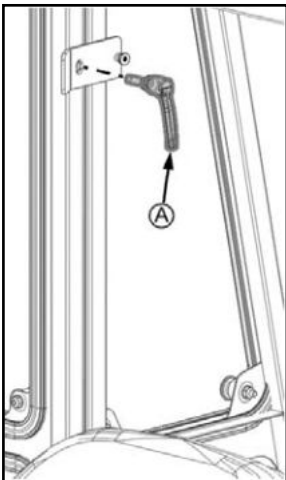

(A) Hand screw

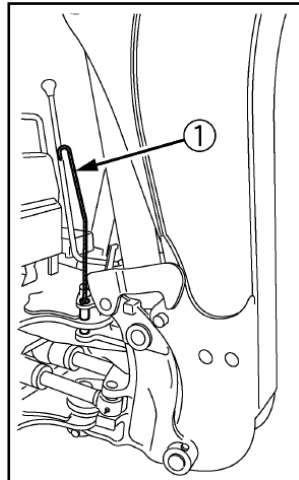

(1) Swing lock pin

3. While sitting in the drivers seat, fully close the dipperstick, curl the bucket and lower the boom until the back of bucket contacts the ground.

4. Keep the stabilizer pads at about 381 mm (15.0 in.) high.

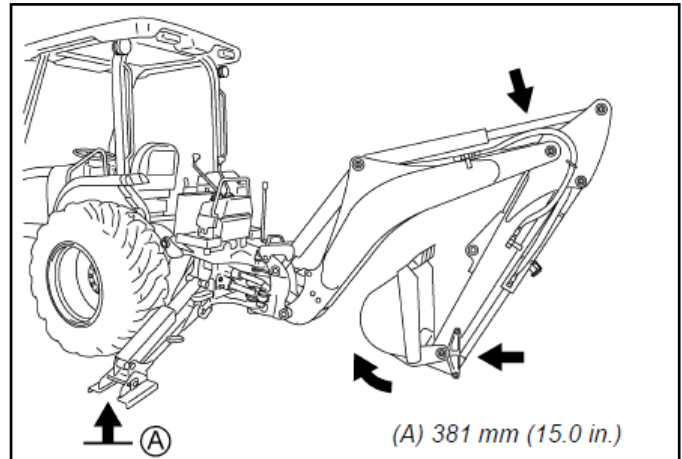

5. Raise the rear wheels slightly with the boom and remove the mounting pins.

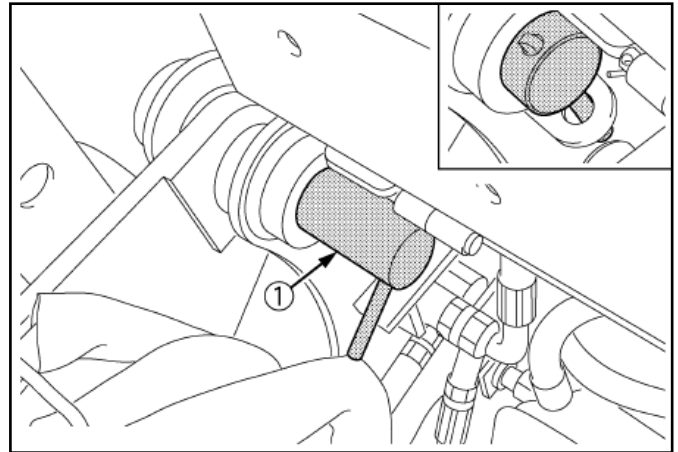

(1) Mounting Pin

6. Slowly raise the boom to disengage the backhoe from the tractor.

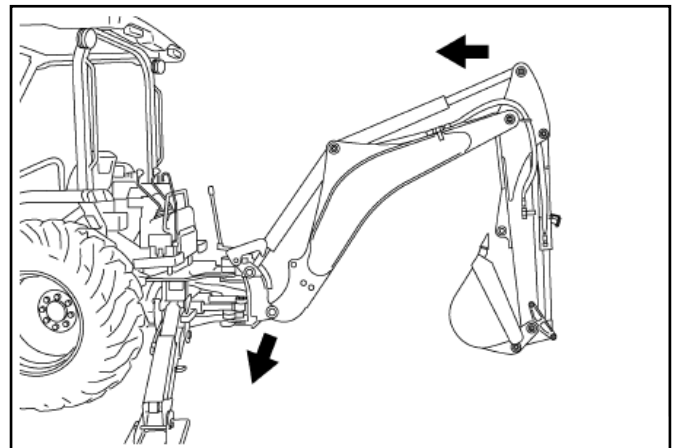

OPERATION

7. Set the swing lock pin to prevent the pivoting of the boom before removing the backhoe.

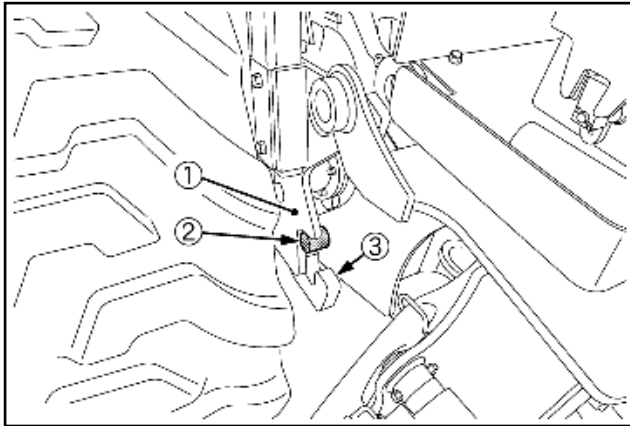

- (1) Guide stop
(2) Mount bar
(3) Support hook

8. Move the tractor forward from the backhoe about 8 inches.

IMPORTANT:

- Be careful not to damage or break the hoses when moving the tractor.
9. Lower the main frame and swing frame onto the ground by operating the boom and stabilizer control levers.

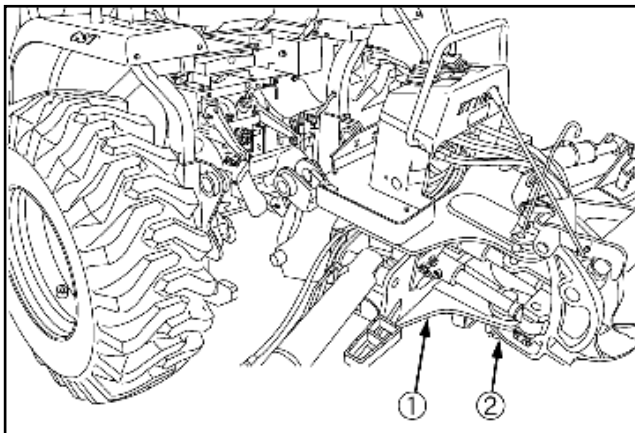

- (1) Main frame
(2) Swing frame

10. Shut off the engine and set the parking brake.
11. Slowly release all hydraulic pressure by moving the backhoe hydraulic control levers in all directions.
12. Disconnect the three hydraulic hoses.

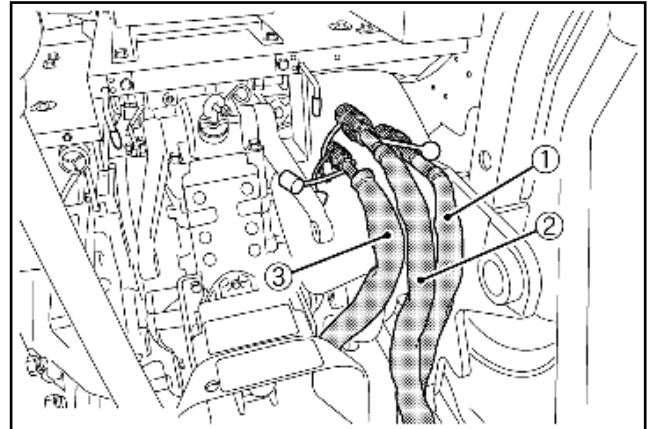

- (1) Inlet hose
(2) Return hose
(3) Swing inlet hose

IMPORTANT:

- Install the dust plugs and the dust cap onto the tractor's hydraulic couplers and nipple to prevent contamination.
13. Switch the two directional valve levers position as follows:
(1) Switch the two directional valve levers to THREE POINT HITCH position by pulling the lever fully backward.

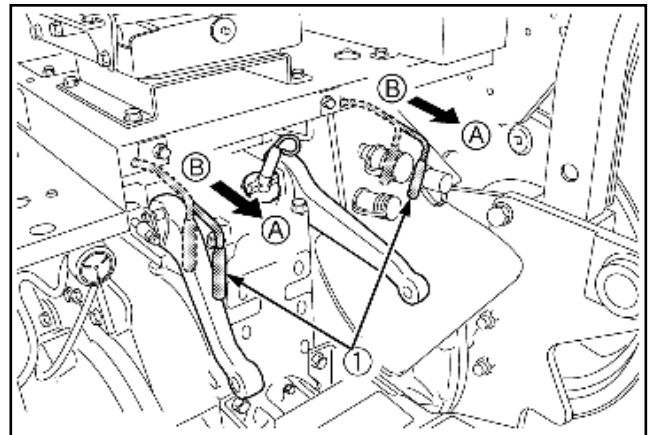

- (1) Directional valve levers
(A) Three point hitch position
(B) Backhoe position

IMPORTANT:

- After dismounting the backhoe, set the directional valve levers in "THREE-POINT HITCH POSITION (A)". If not, the tractor will not start.
 - Do not forget to change the two directional valve levers, otherwise the hydraulic system may be damaged.
14. Restart the engine. Then drive the tractor/loader slowly away from the backhoe.
15. Shut the engine off and remove the key from the tractor. Set the parking brake.

OPERATION

NOTE:

- The optional three point hitch can now be reinstalled on the tractor for use with other rear mount implements.
- Be sure that is sufficient ballast in the rear tires and implement on the three point hitch before using the loader with backhoe removed.

Storage of the Backhoe

1. Store the backhoe in a dry place.
2. Apply a coat of grease to all exposed cylinder rods to prevent rusting.
3. If the backhoe is being stored outside, cover the backhoe with suitable weather cover. This will keep moisture, dirt and other airborne debris from getting into the system.
4. Repair or replace any worn, damaged or missing parts.

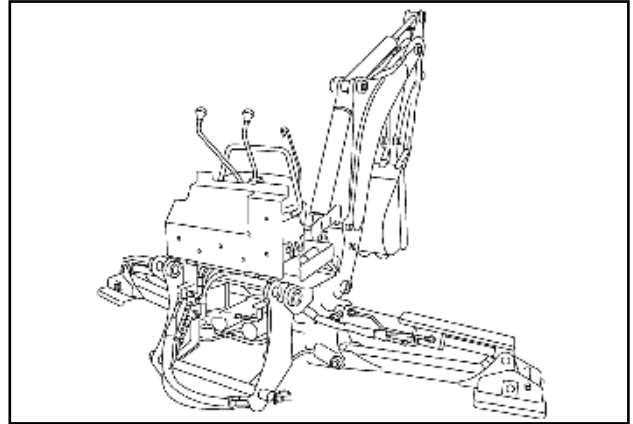
**IMPORTANT:**

- When storing the backhoe, install the dust caps and the dust plug onto the backhoe's hydraulic nipples and coupler to prevent contamination.

OPERATION

Reinstalling the Backhoe

WARNING

To avoid personal injury:

- When starting the engine, always sit in the tractor operator's seat.
- When getting off the tractor, make sure that PTO lever is off and range gear shift lever is in neutral. Set the parking brake.
- Keep hands, feet and body from between tractor and backhoe. Never allow any part of body under the machine.

CAUTION

To avoid personal injury:

- Make sure the tractor PTO is disengaged.

IMPORTANT:

- When reinstalling the backhoe, set the engine speed to low idle.

1. Remove the 3-point hitch and / or drawbar. (if equipped)
2. Lower the position control lever and place the lift arms in lowest position. Lock the position control lever in lowest position with restricting plate.

(1) Position control lever

(A) Down

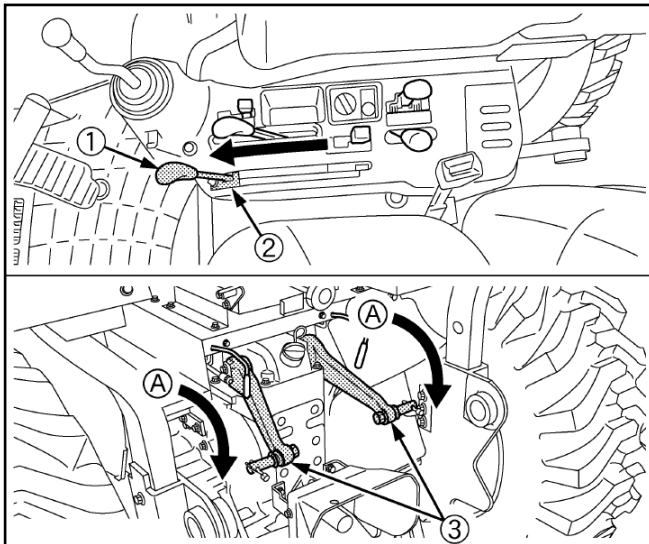

(2) Restricting plate

(3) Lift arm

3. Make sure the swing lock pin is installed.
4. Slowly back the tractor / loader, centering to the backhoe main frame. Stop the tractor 10 to 12 inches away from the backhoe.
5. Shut the engine off and set the parking brake.

5. Connect the three hoses of the backhoe to the tractor and align the hoses in the position as shown.

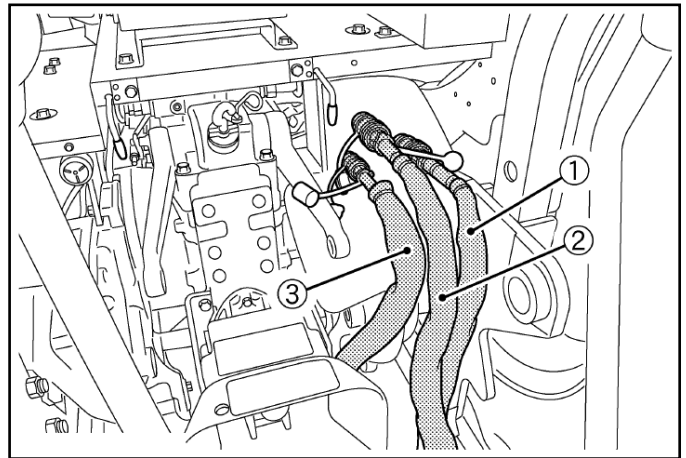

(1) Inlet hose

(2) Return hose

(3) Swing inlet hose

IMPORTANT:

- Make sure these hoses are firmly connected before starting the engine.

6. Switch the two directional valve levers (LH, RH) position as follows:

- (1) Switch the two directional valve levers to BACKHOE position by pushing the lever fully forward.

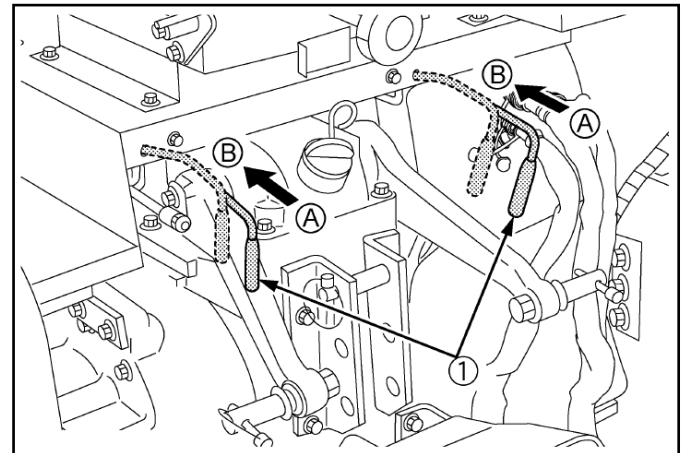

(1) Directional valve lever

(A) Three point hitch position

(B) Backhoe position

7. Switch the two directional valve levers (LH, RH) position as follows:

WARNING

To avoid personal injury or death:

- Do not move the joystick control lever to the swing position.

OPERATION

8. Move the boom to fully raising position and raise the backhoe by operating the stabilizers until the mount bar on the backhoe main frame are slightly higher than the tractor main frame support hooks.

NOTE:

- If the support hooks are not parallel to the mount bars, adjust the stabilizers.

(1) Mount bar

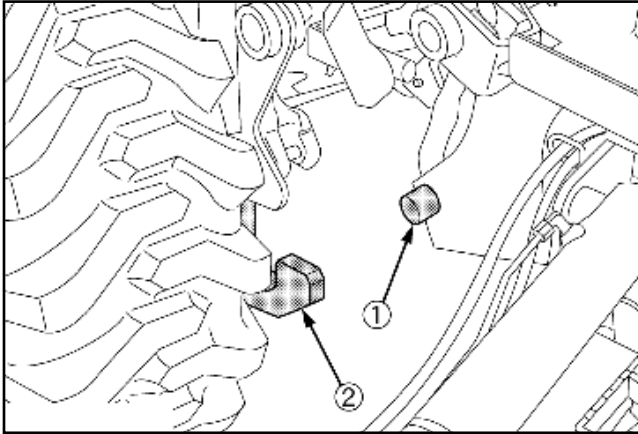

(2) Support hook

9. Move the tractor backward until the support hooks on the tractor main frame are just beneath the mount bar on the backhoe main frame.

(1) Guide stop

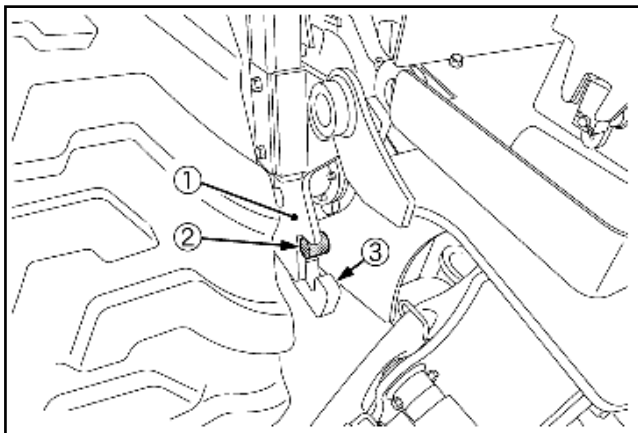

(2) Mount bar

(3) Support hook

10. Lower the mount bar onto the support hooks by operating the stabilizer and boom control levers.
11. Move the boom slowly to the lowering position, and engage the guide plates of the main frame to the bosses of the tractor main frame. Then raise the rear wheels slightly by operating the boom to the lowering direction.
12. Shut off the engine. Reinstall the mounting pins, and insert the slide bar of the mounting pins to the hole of the main frame.

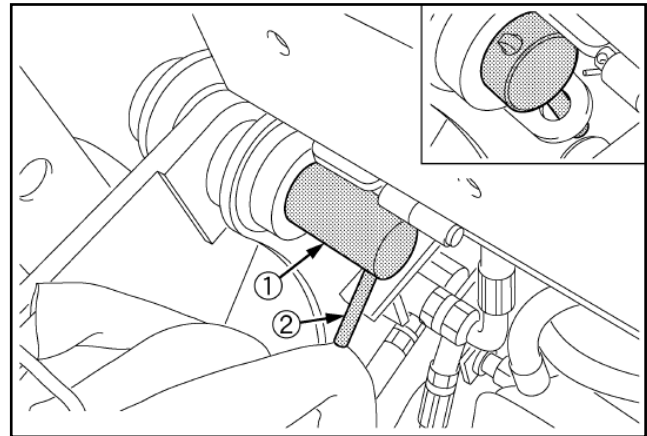

(1) Mounting pin

(2) Slide bar

NOTE:

- Move the tractor / loader / backhoe to an open area and cycle all backhoe functions. This will check their operation and flow oil back through the system, filtering it and refilling each circuit. Check the hydraulic oil level before putting the backhoe into full operation. See "MAINTENANCE" section of the tractor operator's manual for oil type and correct level.

13. Thread both hand screws through backhoe mounting plates into the rear panel tube to secure it.

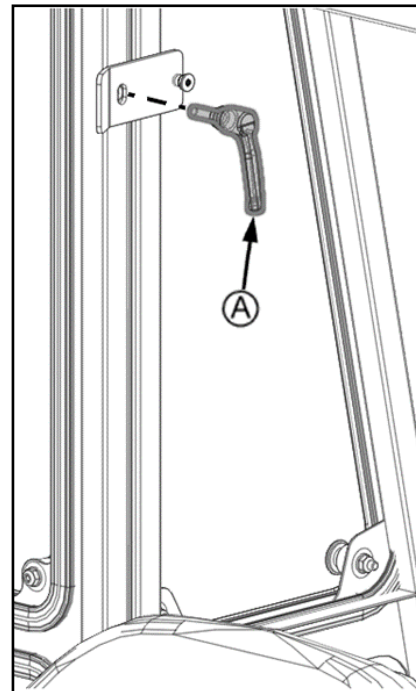

(A) Hand screw

TROUBLESHOOTING

FRONT DOOR TROUBLESHOOTING

Condition	Possible Solution
<ul style="list-style-type: none"> Door latch and striker pin don't line up vertically 	<ul style="list-style-type: none"> Loosen striker pin and move up or down. Use (2) 3/4" wrenches to adjust striker pin.
<ul style="list-style-type: none"> Door latch and striker pin don't line up horizontally 	<ul style="list-style-type: none"> Remove plastic covers on interior door latch. Loosen (3) 1/4-20 hex flange screws. Move interior door latch forward or backward. Loosen striker mount screws and lower outer rear panel screws. Move striker mount forward or backward.
<ul style="list-style-type: none"> Door is not aligned to vehicle 	<ul style="list-style-type: none"> Loosen door hinges and lower hinge mount, if necessary. With the door unlatched, lift up (or lower down) on the door handle until the door is aligned with the vehicle. Have an assistant sit inside the vehicle and determine the new height required for the striker pin. Have the assistant adjust the height of the striker pin. Re-latch the door and tighten all fasteners.
<ul style="list-style-type: none"> Door latch is unable to be double-latched (2 clicks have not been heard) 	<ul style="list-style-type: none"> Remove the black plastic cover. Loosen (2) 5/16-18 Phillips head screws. Move the latch in or out. Re-tighten the screws. Check to make sure acorn nut on outer handle plunger is adjusted properly to prevent door from opening unexpectedly

L47 SERVICE PARTS BREAKDOWN

COWL ASSEMBLY
P/N: 8SV-KL47-05

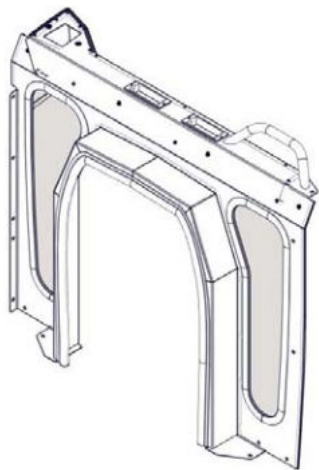

WINDHIELD ASSEMBLY
P/N: 8SV-KL47-02

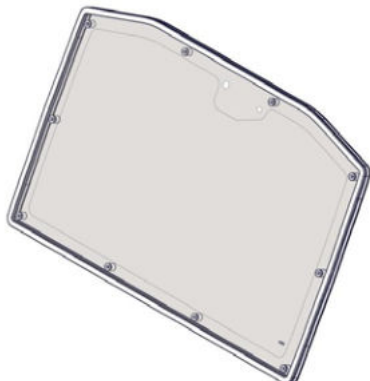

WINDHIELD SUPPORT ASSEMBLY
P/N: 8SV-KL47-17



HEATER REAR DUCT
P/N: 8SV-KL47-22

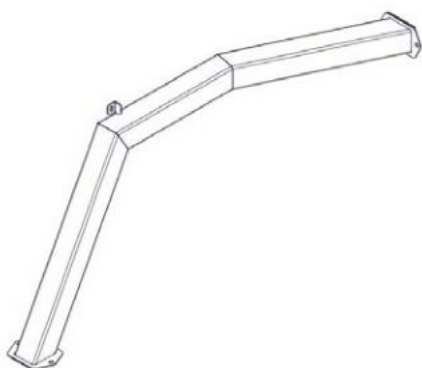

REAR PANEL ASSEMBLY
P/N: 8SV-KL47-06

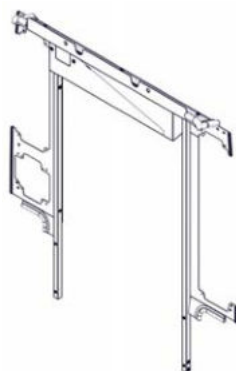

REAR PANEL WINDOW, UPPER, RIGHT
P/N: 8SV-K6247-21B



REAR PANEL WINDOW, LEFT
P/N: 8SV-K6247-21A



LOWER REAR FILLER, RIGHT
P/N: 8SV-KL47-21-R

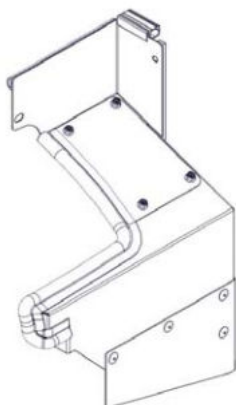

LOWER REAR FILLER, LEFT
P/N: 8SV-KL47-21-L

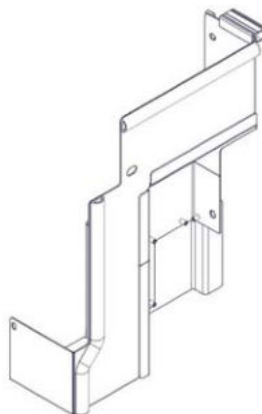

REAR PANEL WINDOW, LOWER, RIGHT
P/N: 8SV-K6247-21C



L47 SERVICE PARTS BREAKDOWN

UPPER REAR MOUNT,
RIGHT
P/N: 8SV-KL47-18R

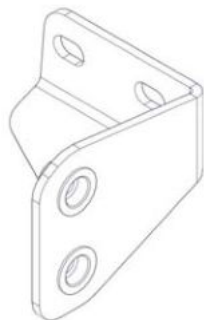

UPPER REAR MOUNT,
LEFT
P/N: 8SV-KL47-18L

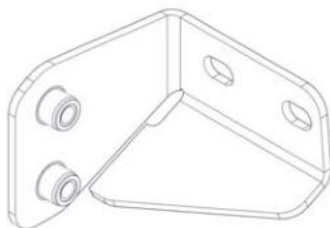

BACKHOE FOOTER,
RIGHT
P/N: 8SV-KL47BCFT-R

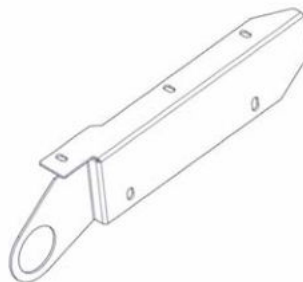

BACKHOE FOOTER,
LEFT
P/N: 8SV-KL47BCFT-L

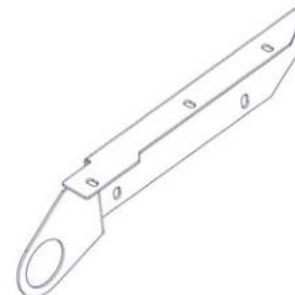

HAND SCREW ASSEMBLY
P/N: 8SV-K6247-HSA



ROPS CLAMP BRKT
P/N: 8SV-K6247-21

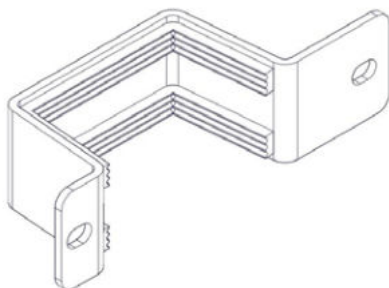

REAR PANEL, LOWER
ROPS BRKT, RIGHT
P/N: 8SV-KL47RPRB-R

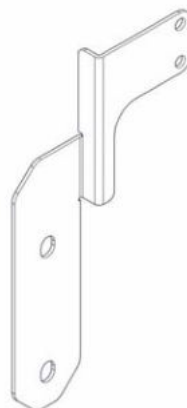

REAR PANEL, LOWER
ROPS BRKT, LEFT
P/N: 8SV-KL47RPRB-L

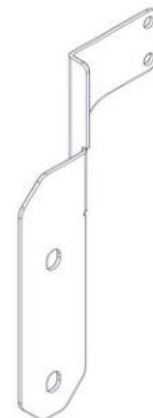

FLOORMAT
P/N: 8SV-9FR-KL47FLM

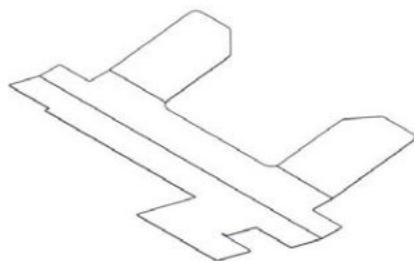

BACKHOE CAB
P/N: 8SV-K6247BC



L47 SERVICE PARTS BREAKDOWN

SIDEFRADE, LEFT
P/N: 8SV-KL47-09L



DOOR ASSEMBLY,
LEFT
P/N: 8SV-KL47-07L



SIDE WINDOW
ASSEMBLY, LEFT
P/N: 8SV-K6247-12L



SIDEFRADE, RIGHT
P/N: 8SV-KL47-09R

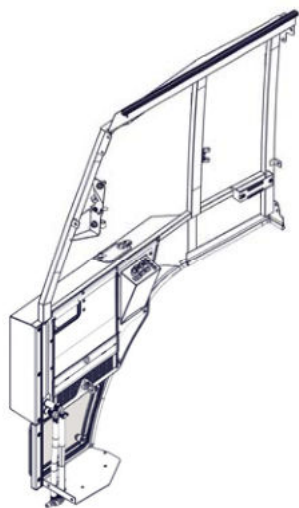

DOOR ASSEMBLY,
RIGHT
P/N: 8SV-KL47-07R

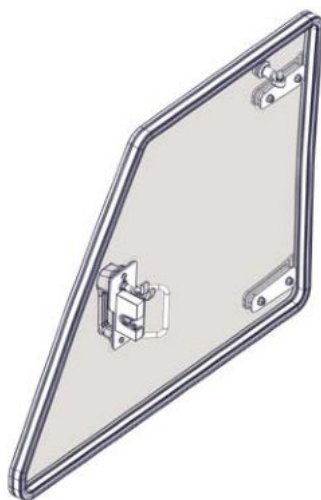

SIDE WINDOW
ASSEMBLY, RIGHT
P/N: 8SV-K6247-12R



BOTTOM SIDEFRADE
WINDOW, RIGHT
P/N: 8SV-KL47-30

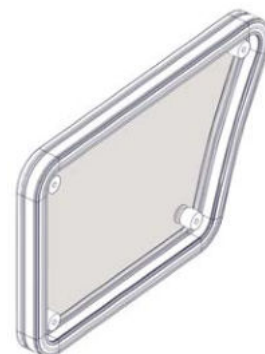

L47 SERVICE PARTS BREAKDOWN

ADDITIONAL SERVICE PARTS		
PART NUMBER:	QTY/KIT:	DESCRIPTION:
9SV-9HR0092	1	LOUVER VENT. 4" ROUND (UNDERSIDE OF COWL)
9SV-9HR-L	1	LOUVER VENT. RECTANGULAR (TOP OF COWL. REAR PANEL)
8SV-GL9X28	1	COWL WINDOW AND MOUNTING RUBBER
8SV-K6247BCW03L	1	BACKHOE CAB WINDOW. UPPER LEFT SIDE
8SV-K6247BCW03R	1	BACKHOE CAB WINDOW. UPPER RIGHT SIDE
8SV-K6247BCW04L	1	BACKHOE CAB WINDOW. LOWER LEFT SIDE
8SV-K6247BCW04R	1	BACKHOE CAB WINDOW. LOWER RIGHT SIDE
8SV-K6247BCW02	1	BACKHOE CAB REAR WINDSHIELD
8SV-K6247BCW	1	BACKHOE CAB REAR WINDSHIELD (GLASS AND BULB RUBBER ONLY)
8SV-9SW-18X29	1	BACKHOE CAB SLIDING WINDOW
9SV-9DL-196	1	DECAL. TLB CRUSH WARNING
9PM3	1	INTERIOR REAR VIEW MIRROR
9SV-9HR0093	1	R3/8 HEATER NIPPLE
9SV-9HR0094	1	90 DEGREE HEATER FITTING (SUPPLY)
9SV-PWA14-18DHW	1	WPER ARM. WET. J-HOOK (FRONT WINDOW)
9SV-9PWB20FBJH	1	WPER BLADE, 20" FLEX BLADE. J-HOOK (FRONT WINDOW)
9PWM110	1	WPER MOTOR. 110 DEGREE SWEEP (FRONT WINDOW)
9PWM852	1	85 DEGREE WIPER MOTOR (REAR WINDOW)
9PWA14/16	1	WPER ARM 14"-16" (REAR WINDOW)
9PWK-HB	1	GLASS MOUNT KIT FOR WIPER MOTORS (FRONT OR REAR WINDOW)
9PWB20-FB	1	WPER BLADE, 20". FLEX (REAR WINDOW)
9SV-K6247-WHDE	1	WIRE HARNESS. DIRECTIONALS
9SV-KF2-RWH	1	WIRE HARNESS. POWER. WITH FUSE AND RELAY
9SV-KL47-HWK	1	HARDWARE KIT
9SV-OHRL-G	1	OUTSIDE DOOR HANDLE (GLASS DOORS)
9SV-HRL	1	INSIDE DOOR LATCH. LEFT DOOR
9SV-DL06S	1	INSIDE DOOR LATCH. RIGHT DOOR
9SV-WL1	1	POP-OUT LATCH (SIDEFRAME SIDE WINDOWS. BACKHOE REAR WINDSHIELD)
9PHW010-W	1	BRASS HINGE WASHERS
9SV-GS04Q	1	GAS SPRING. DOOR. 14-7/16 LONG, 17LB. QUICK RELEASE END
8SV-9HR0037	1	BLOWER MOTOR
9SV-9PH33-5/8	1	HEATER CORE
9SV-OHC-22	1	WASHER SWITCH
9SV-OHC-6	1	BLOWER SWITCH
9SV-HVC	1	HEATER VALVE CONTROLLER
9SV-9HR0046	1	HEATER VALVE KNOB
9SV-9HR0034	1	HEATER CONTROL CABLE
9SV-9HR0036	1	HEATER VALVE, 5/8" HOSE BARBS
9SV-APBR	1	CIRCUIT BREAKER. 5 AMP. PUSH RESET
9SV-APBR15	1	CIRCUIT BREAKER. 15 AMP. PUSH RESET
9SV-9HR0096	1	AIR FILTER
9SV-9DL07	1	WASHER DOOR LATCH
9SV-9PWW2	1	WASHER BOTTLE AND PUMP, 1/2 GALLON
9SV-9HR0039	1	HOSE FITTING, 90 DEGREE ELBOW, 5/8" BARBS, PLASTIC

TRIM LOK,
STD,
1/16" - 1/8"
GRIP



9SV-PRO1-20

3/4" SIDE BULB,
1/4" GRIP



9SV-PR38-15

1" ROUND
BULB, 1/16"
GRIP



9SV-PR19-10

EXPAND-A-
FOAM 1/4 X 3/4"



9SV-PR43-15

WINDOW
RUBBER



9SV-PR10-20

1/2"
WEATHER
SEAL



9SV-PR20-10

ARCH PSA



9SV-PRO9-10

5/8" STD
BULB,
1/16" GRIP



9SV-PRO2-15

3/4" SIDE BULB,
1/16" GRIP



9SV-PR17-20

BOLT TORQUE

BOLT TORQUE SPECIFICATIONS

GENERAL TORQUE SPECIFICATION TABLE

Use the following torques when special torques are not given. These values apply to fasteners as received from suppliers, dry, or when lubricated with normal engine oil. They do not apply if special graphited or moly disulphide greases or other extreme pressure lubricants are used. This applies to both UNF and UNC threads. Remember to always use grade five or better when replacing bolts.

IMPORTANT: On all PLATED GRADE 8 bolts, reduce torque 15% from listed bolt torque specification.

SAE Grade No.		2				5				8*			
Bolt head identification mark as per grade. NOTE: Manufacturing Marks Will Vary													
		TORQUE		TORQUE		TORQUE		TORQUE		TORQUE		TORQUE	
Bolt Size		Pounds Feet		Newton-Meters		Pounds Feet		Newton-Meters		Pounds Feet		Newton-Meters	
Inches	Millimeters	Min.	Max.	Min.	Max.	Min.	Max.	Min.	Max.	Min.	Max.	Min.	Max.
1/4	6.35	5	6	7	8	9	11	12	15	12	15	16	20
5/16	7.94	10	12	14	16	17	20.5	23	28	24	29	33	39
3/8	9.53	20	23	27	31	35	42	48	57	45	54	61	73
7/16	11.11	30	35	41	47	54	64	73	87	70	84	95	114
1/2	12.70	45	52	61	70	80	96	109	130	110	132	149	179
9/16	14.29	65	75	88	102	110	132	149	179	160	192	217	260
5/8	15.88	95	105	129	142	150	180	203	244	220	264	298	358
3/4	19.05	150	185	203	251	270	324	366	439	380	456	515	618
7/8	22.23	160	200	217	271	400	480	542	651	600	720	814	976
1	25.40	250	300	339	406	580	696	787	944	900	1080	1220	1464
1-1/8	25.58	-	-	-	-	800	880	1085	1193	1280	1440	1736	1953
1-1/4	31.75	-	-	-	-	1120	1240	1519	1681	1820	2000	2468	2712
1-3/8	34.93	-	-	-	-	1460	1680	1980	2278	2380	2720	3227	3688
1-1/2	38.10	-	-	-	-	1940	2200	2631	2983	3160	3560	4285	4827

*Thick Nuts must be used with Grade 8 bolts

METRIC BOLT TORQUE SPECIFICATIONS



Size of Screw	Property Class	Course Thread			Fine Thread		
		Pitch (mm)	Pounds Feet	Newton-Meters	Pitch (mm)	Pounds Feet	Newton-Meters
M6	5.6	1.0	3.6-5.8	4.9-7.9	-	-	-
	8.8		5.8-9.4	7.9-12.7		-	-
	10.9		7.2-10	9.8-13.6		-	-
M8	5.6	1.25	7.2-14	9.8-19	1.0	12-17	16.3-23
	8.8		17-22	23-29.8		19-27	25.7-36.6
	10.9		20-26	27.1-35.2		22-31	29.8-42
M10	5.6	1.5	20-25	27.1-33.9	1.25	20-29	27.1-39.3
	8.8		34-40	46.1-54.2		35-47	47.4-63.7
	10.9		38-46	51.5-62.3		40-52	54.2-70.5
M12	5.6	1.75	28-34	37.9-46.1	1.25	31-41	42-55.6
	8.8		51-59	69.1-79.9		55-68	75.9-92.1
	10.9		57-66	77.2-89.4		62-75	84-101.6
M14	5.6	2.0	49-56	66.4-75.9	1.5	52-64	70.5-86.7
	8.8		81-93	109.8-126		90-106	122-143.6
	10.9		96-109	130.1-147.7		107-124	145-168
M16	5.6	2.0	67-77	90.8-104.3	1.5	69-83	93.6-112.5
	8.8		116-130	157.2-176.2		120-138	162.6-187
	10.9		129-145	174.8-196.5		140-158	189.7-214.1
M18	5.6	2.0	88-100	119.2-136	1.5	100-117	136-158.5
	8.8		150-168	203.3-227.6		177-199	239.8-269.6
	10.9		175-194	237.1-262.9		202-231	273.7-313
M20	5.6	2.5	108-130	146.3-176.2	1.5	132-150	178.9-203.3
	8.8		186-205	252-277.8		206-242	279.1-327.9
	10.9		213-249	288.6-337.4		246-289	333.3-391.6