

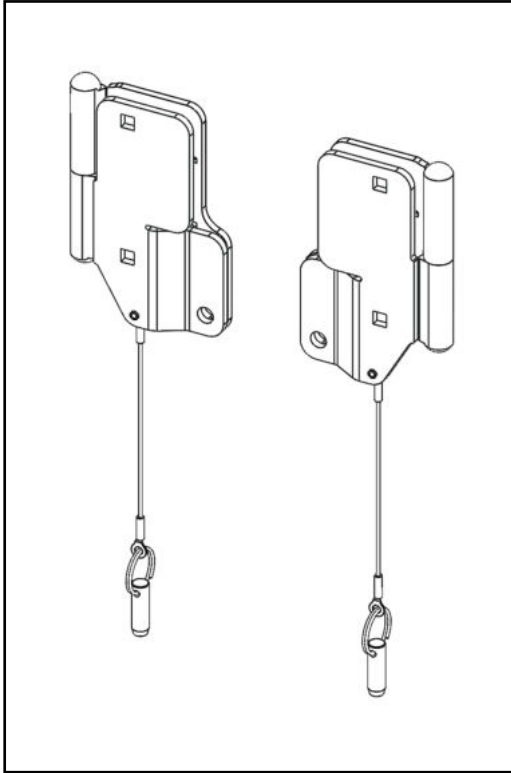

**ARTILLIAN ROPS MOUNTED TOOL BAR  
QUICK RELEASE KIT  
P/N: 1RMTBQR**



The Artillian ROPS Mounted Tool Bar is an innovative system for attaching accessories to your 2-Post tractor ROPS.

This Quick Release Kit allows the tool bar to be removed and re-installed in seconds, for storage, access to a rear seat for a backhoe, to use a 3-point hitch, or even for a quick exchange of accessories.

The proprietary *Cam Lever Latching* feature found on the many optional accessories allows for installation and removal of a given accessory in seconds.

Approximate Installation Time
Experienced Dealer Technician – 15 Minutes
Average Dealer Technician – 25 Minutes
Do-It-Yourself – 45 Minutes

Approximate Product Specifications
Weight: 3.41 lbs. (not including accessories)
Capacity: 100 lbs. (including accessories)



**CAUTION**

***Do not exceed the rated capacity for the Tool Bar or its accessories. Doing so may result in damage to the Tool Bar and will void the warranty.***

The contents of this envelope are the property of the owner. Leave with the owner when installation is complete.

All images shown are for illustration purposes only. Actual product may vary due to product enhancement.

# KIT INSTALLATION

1. Park the vehicle on a flat, level surface.
2. Install the Tool Bar ROPS brackets onto the ROPS per the instructions included with the Tool Bar kit. Tighten all hardware.

**TIP:** It may be helpful to install the mounting bar and brackets to ensure the bar will be level.

If a Tool Bar Kit is already installed on the vehicle, remove the tube clamps and the mounting bar from the ROPS brackets, but leave the ROPS brackets installed.

3. Attach the Pin Brackets from the Quick Release Kit onto the ROPS brackets with the pins oriented to the outside of the vehicle and facing up. Use two 5/16-18 x 1" long carriage bolts, through the pin brackets, with fender washers, and locknuts. Repeat for the other side. Snug fasteners, but leave loose enough for pin bracket to move within the curved slots. See figure 3.

**CAUTION:** This kit includes 1" long and 3/4" long carriage bolts. Use the longer bolts to attach the pin brackets to the ROPS brackets.

4. Apply grease to both pins.
5. Slide a Bar Bracket from the quick release kit onto each pin and insert two 5/16-18 x 3/4" carriage bolts through the square holes in each bracket (see figure 5). Rotate the bracket parallel to the pin bracket.
6. Place a Tube Clamp from the Tool Bar Kit over the upper carriage bolt of the bar bracket and install a nut loosely on the upper screw. Repeat for the other side.
7. Slide the Mounting Bar up into the tube clamps and center the bar. Install a nut onto the lower bolt for each side and tighten all the tube clamp fasteners snug. See figure 7.
8. Make sure the mounting bar is centered and level, and that both bar brackets are fully seated on the pins, then tighten the hardware for the bar brackets and the pin brackets. Make certain the mounting bar assembly will easily lift off the pins. Adjust if necessary.



## WARNING

**Do not allow the Tool Bar to hang from a single pin, or apply leverage to the single pin. Doing so will result in damage and void the warranty.**

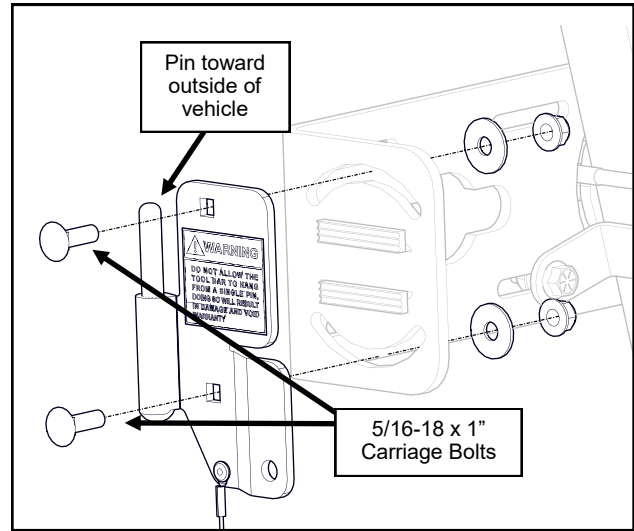

Fig. 3 (Attach Pin Brackets to ROPS Brackets)

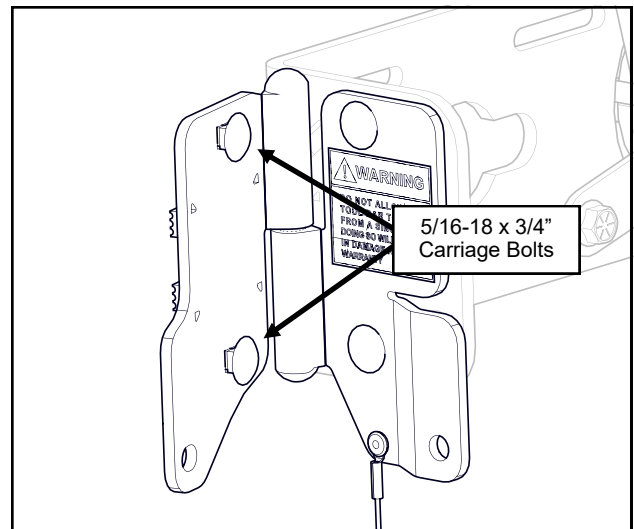

Fig. 5 (Place Bar Brackets & bolts)

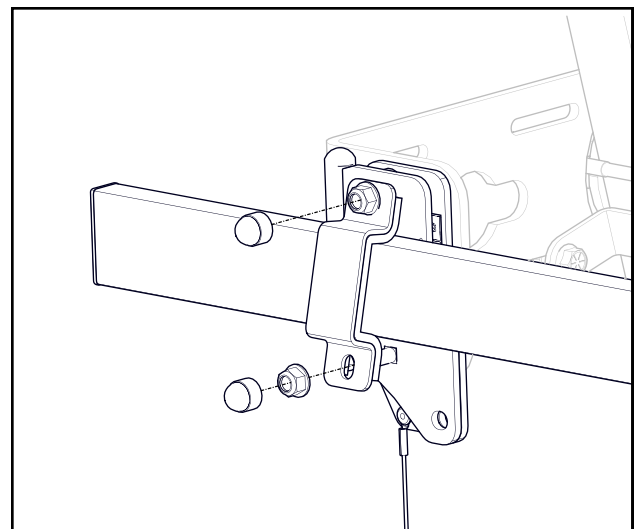

Fig. 6 (Attach Bar to Brackets)

# FEATURES AND OPERATION

## FEATURES:

1. The brackets of the Quick Release Kit are designed to fit within the width of the ROPS Brackets, so as not to interfere with the placement of any of the accessories.
2. The Quick Release Kit includes holes in the mating brackets as well as tethered locking pins to prevent the Mounting Bar assembly from lifting off while driving over bumpy or uneven terrain.
3. For added security, a padlock (not included), can be installed on one or both brackets instead of the quick release pins.

## OPERATION

1. Due to the excessive vibrations generated by a tractor, the ROPS Mounted Tool Bar fasteners may loosen up over time. It is recommended that the fasteners are checked and retightened, as required, regularly.
2. The Quick Release Kit can be combined with multiple Tool Bars or even the Wall Mounted Tool bar to allow for storage or interchange of different sets of accessories.



**Do not allow the Tool Bar to hang from a single pin, or apply leverage to the single pin. Doing so will result in damage and will void the warranty.**

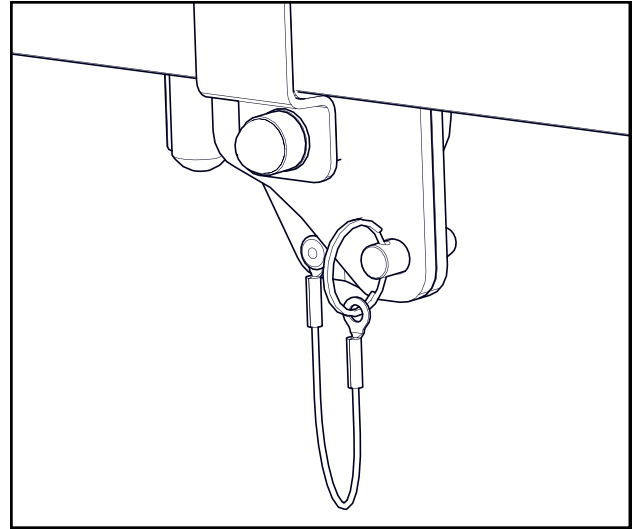

Fig. 2 (Tethered Pin)

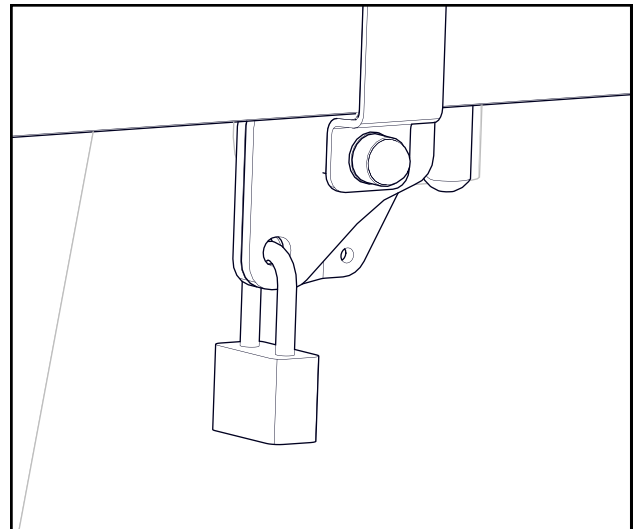

Fig. 3 (Optional Padlock)

# SERVICE PARTS:

PIN BRACKET ASSEMBLY, LEFT  
P/N: 8SV-110-00080-L (QTY.: ONE)



PIN BRACKET ASSEMBLY, RIGHT  
P/N: 8SV-110-00080-R (QTY.: ONE)



1/2" V-GROOVE WEATHERSEAL  
P/N: 9SV-PR20-10 (QTY.: 10 FEET)

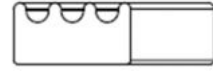

---

BAR BRACKET ASSEMBLY, LEFT  
P/N: 8SV-110-00081-L (QTY.: ONE)

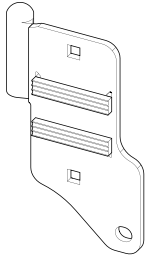

BAR BRACKET ASSEMBLY, RIGHT  
P/N: 8SV-110-00081-R (QTY.: ONE)

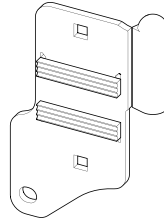

# AVAILABLE ACCESSORIES:

ROPS MOUNTED TOOLBOX, LARGE  
P/N: 1RMTBXS



ROPS MOUNTED TOOLBOX, X-LARGE  
P/N: 1RMTBXL

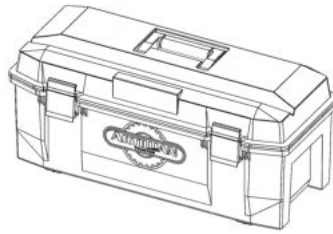

ROPS MOUNTED TOOL RACK  
P/N: 1RMTRK

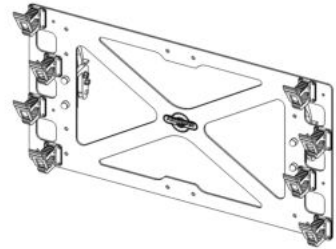

ROPS MOUNTED CHAINSAW MOUNT  
P/N: 1RMCSM  
(chainsaw shown for illustration purposes)

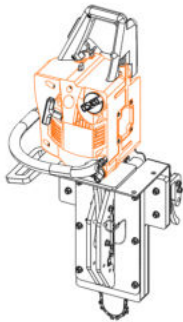

ROPS MOUNTED FUEL CAN HOLDER  
P/N: 1RMFCH

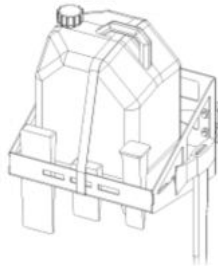

ROPS MOUNTED TOOL BASKET  
P/N: 1RMTBSK

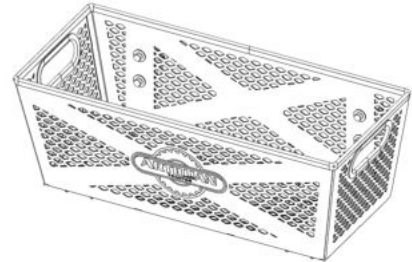

BEVERAGE COOLER HOLDER  
P/N: 1RMBCH  
(cooler shown for illustration purposes)

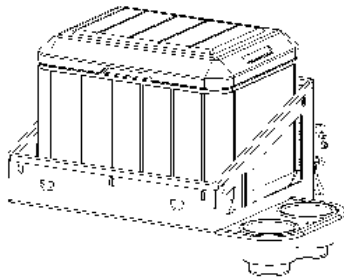

ROPS MOUNTED 5-GALLON BUCKET  
HOLDER - P/N: 1RM5GBH  
(Bucket shown for illustration purposes)

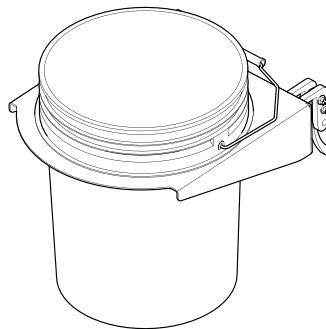

TOOL BAR WALL MOUNT  
P/N: 1RMTBWM



## MORE ACCESSORIES COMING SOON!