



Polaris Ranger 1000 Door Restraint Kit
p/n:1POLXP1000GS
Fits UTV Models:
POLARIS RANGER 900, XP 900, 1000 &
XP 1000



Available Options:

- 1. Door Kit (P/N: 1POLXP1000DR)
- 2. Roof Kit (P/N: 1POLXP1000RF)
- 3. Rear Panel Kit (P/N: 1POLXP1000RP)
- 4. Windshield Kit (P/N 1POLXP1000WS)
- 5. Front Wiper Kit (P/N 1POLXP1000WK)
- 6. Side View Mirrors (P/N: 9PM5)

Approximate Installation Time *
Experienced Dealer Technician – 15 minutes
Average Dealer Technician – 20 minutes
Do-It-Yourself – 30 minutes

Approximate Product Specifications
Weight: 2.0 lbs.

(*=Not including accessories)

Register your new product quickly online at Curtiscab.com/product-registration/



Curtis encourages all customers to register their Curtis products. However, failure to do so will not diminish right to warranty. Curtis Industries does not sell or share your information with anyone else.

Download a digital copy of your installation instructions online at Curtiscab.com/literature/



Curtis strives to continuously improve our products, technical documentation, etc. Therefore, the installation manual for this product may have been updated after your product was packaged. The latest revision of the installation manual can always be found at the website above.

The contents of this envelope are the property of the owner. Leave with the owner when installation is complete.

TABLE OF CONTENTS

WARNINGS, TIPS, & REQUIRED TOOLS..... 2
 KIT INSTALLATION 3-4
 CARE AND MAINTENANCE..... 4
 SERVICE PARTS 4
 BOLT TORQUE SPECIFICATIONS 5

WARNINGS, TIPS, & REQUIRED TOOLS

Curtis cabs, kits, and accessories feature an assembly of parts designed for your vehicle which require adjustment and alignment of components to accommodate vehicle variations and provide proper weather protection. For accurate installation, proper operation, and years of satisfaction, please read and understand the installation and owner's manual fully prior to installing this kit.

From all of us at Curtis, we thank you for choosing our product.



ADDED WEIGHT NOTICE

Curtis Cabs, blades and general accessories add additional weight to the base vehicle. All Curtis accessory weights are listed in product brochures. Deduct the accessory's total weight from the vehicle's rated capacity and never exceed the vehicle's rated capacity including driver and passenger.

WARNING Exposure to Carbon Monoxide can Cause illness, serious injury or death. Never operate vehicle if suspicious of Carbon Monoxide. Inspect exhaust system for leaks monthly. Leaks can result from loose connections, corrosion, cracks or other damage to the exhaust manifold. If leaks are found, repair or replace exhaust system. Do not use vehicle until repair or replacement is complete.

WARNING

Serious Injury or Death

	This cab enclosure does not provide protection from rollover or other accidents.
	This cab enclosure does not provide protection from flying objects including golf balls.
	This cab enclosure does not provide protection from lightning. When lightning threatens take cover and do not operate vehicle.

California Health and Safety Proposition 65 Warning: This product may contain chemicals known to the state of California to cause cancer and birth defects or other reproductive harm.

GENERAL INFORMATION BEFORE YOU START

HELPFUL HINTS:

- Read and understand all instructions before beginning.

TOOLS REQUIRED:

- Set of Standard Open-End Wrenches
- Set of Torx Bit Wrenches
- Electrical and Masking Tape
- Drill/Driver
- 1/4" Drill bit
- #2 Phillips screwdrivers
- Awl
- Center Punch

KIT INSTALLATION

STEP 1: (KIT INSTALLATION)

This kit requires Curtis Door Kit (P/N: 1POLXP1000DR)

1.1 Per figure 1.1, remove and set aside screw on both the left and right side of the vehicle.

Tools required

T40 Torx Bit

1.2 Per figure 1.2, install spacer and door side ball stud using hardware removed on step 1.1. It is important to orient the plate down and toward center of vehicle as shown. Install on both the left and right side of the vehicle.

Tools required

T40 Torx Bit

Hardware Used

WASHER SLEEVE .459 X 5/8 X 1/4

Qty

2

If Curtis door kit frames have pre-drilled holes as shown in figure 1.3, skip step 1.3 and continue to step 1.4.

1.3 Per figure 1.3, drill (2) 1/4" holes thru the Velcro, door frame, and vinyl. Drill both the left and right doors.

Tools required

Drill/Driver

Center punch

1/4" drill bit

If you have just drilled holes in the door, skip step 1.4 and continue to step 1.5.

1.4 Per figure 1.4, use an awl to punch (2) holes through Velcro and vinyl using pre-drilled holes in door frame as guides. Punch holes in both the left and right door.

Tools required

Awl

1.5 Per figure 1.5, install backing plate (sandwich between outside of door frame and inside of vinyl), door side ball stud, and mounting hardware. Install brackets and plates on both the left and right doors.

Tools required

#2 Phillips screwdrivers

3/8" Open-End Wrench

Hardware Used

#10-32 X 3/4 Pan Head Screw

Qty

4

#10-32 Hex Lock Nut

4

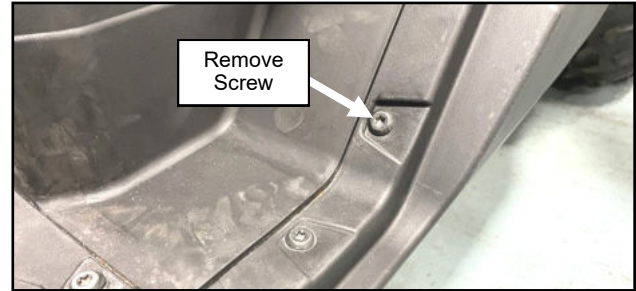

Fig. 1.1 (Remove Screw, Left side of Vehicle)

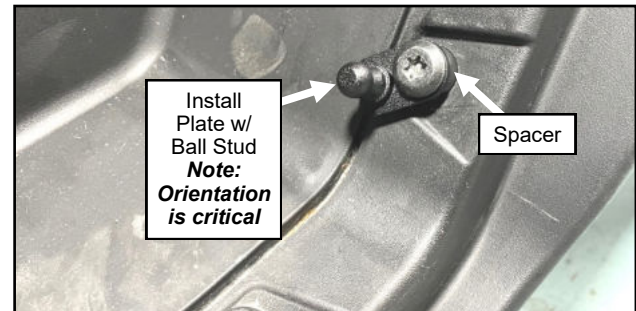

Fig. 1.2 (Install Vehicle Side Ball Stud)

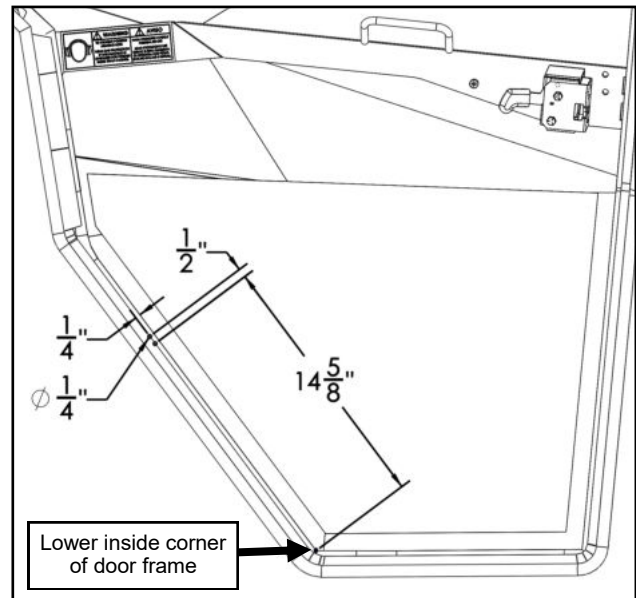

Fig. 1.3 (Drill Door Frame, as needed)

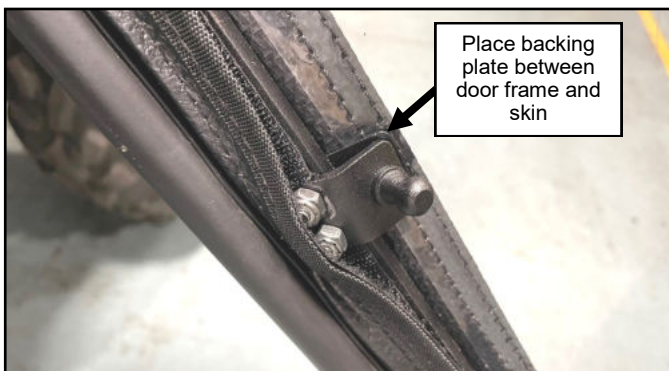

Fig. 1.5 (Install Door Ball Stud Bracket and Backing Plate)



Fig. 1.4 (Punch holes thru Velcro and Vinyl, as needed)

KIT INSTALLATION

STEP 1: (KIT INSTALLATION CONT'D)

1.6 Install the provided gas shocks on the left and right doors per figure 1.6 (left door shown). Make sure that the rod of the gas shock is pointing down hill. Installation of kit is now fully complete.



Fig. 1.6 (Install Gas Shock on Door)

CARE AND MAINTENANCE

- Check and tighten hardware after 40 hours of operation. Periodically inspect and tighten hardware for the remainder of the unit's life.

POLARIS RANGER 1000 DOOR RESTRAINT KIT SERVICE PARTS

GAS SPRING, 20", 10LBS W/QUICK RELEASE END
(SET OF 2) P/N: 9SV-GS10Q

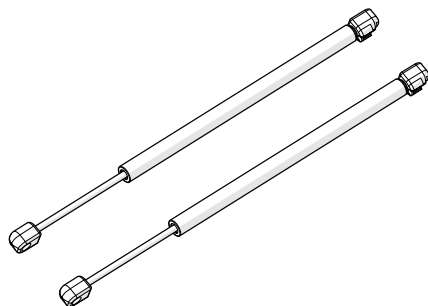

Tightening of Non-Structural Bolts

For light or medium duty fastening, Curtis recommends using a general industry standard of tightening until snug and then giving an additional one quarter turn of the tool as deemed reasonable for the application (i.e.: at the installer's discretion).

If torque values are required, the examples listed below are intended as a reasonable reference for use in the majority of non-structural fastener applications such as: small diameter fasteners; bolts passing thru tubing, glass, plastic, nylon or rubber washers, threaded inserts, etc.

If more than one application below applies, use the lower torque value.

FASTENER SIZE:	FASTENER TYPE:	WASHER MATERIAL:	APPLICATION:	TORQUE (INCH-POUNDS) (±5)
#10	Machine Screws	-	in Nylon P-Clamps	20
#10	Machine Screws	-	Strobe Light (plastic base)	35
M5	Set Screws	-	Wiper Arm	20
1/4"	Cap Nut	-	Windshield Wiper	20
1/4"	Bolts	-	Tubing (5/8" to 3/4" wide)	132
1/4"	Bolts	Rubber	-	60
1/4"	Bolts	Nylon / Plastic	-	72
1/4"	Bolts	-	Factory Installed Threaded Inserts	132
5/16"	Bolts	-	Tubing (1" or wider)	60
5/16"	Flat Head Bolts	-	Plastic Windshield Hinge	79
5/16"	Bolts	Rubber	-	120
5/16"	Bolts	Nylon / Plastic	-	150
5/16"	Ball Studs	-	-	150
5/16"	Bolts	-	Factory Installed Threaded Inserts	240
3/8"	Bolts	-	Tubing	120
M12	Door Striker Pins	-	-	120