

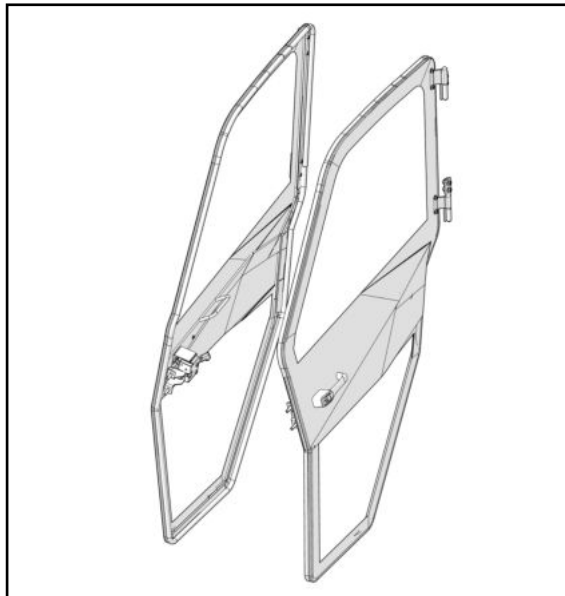

INSTALLATION & OWNER'S MANUAL

**Polaris Ranger 1000 Door Kit**  
**Kit p/n:1POLXP1000DR**  
**Fits UTV Models:**  
**POLARIS RANGER 900, XP 900, 1000**  
**& XP 1000**



**Available Options:**

- 1. Roof Kit (P/N: 1POLXP1000RF)
- 2. Windshield Kit (P/N: 1POLXP1000WS)
- 3. Rear Panel Kit (P/N: 1POLXP1000RP)
- 4. Front Wiper Kit (P/N 1POLXP1000WK)
- 5. Side View Mirrors (P/N: 9PM5)
- 6. Door Restraint Kit (P/N: 1POLXP1000GS)

Approximate Installation Time *
Experienced Dealer Technician – 30 minutes
Average Dealer Technician – 45 minutes
Do-It-Yourself – 60 minutes

Approximate Product Specifications
Weight: 56.5 lbs.
Cab Width: 61 inches

(\*=Not including accessories)

**Register** your new product quickly online at [Curtiscab.com/product-registration/](http://Curtiscab.com/product-registration/)



Curtis encourages all customers to register their Curtis products. However, failure to do so will not diminish right to warranty. Curtis Industries does not sell or share your information with anyone else.

**Download** a digital copy of your installation instructions online at [Curtiscab.com/literature/](http://Curtiscab.com/literature/)



Curtis strives to continuously improve our products, technical documentation, etc. Therefore, the installation manual for this product may have been updated after your product was packaged. The latest revision of the installation manual can always be found at the website above.

The contents of this envelope are the property of the owner. Leave with the owner when installation is complete.

Rev. A, 06/30/2021

p/n: IM-1POLXP1000DR

# TABLE OF CONTENTS

WARNINGS, TIPS, & REQUIRED TOOLS..... 2  
 KIT INSTALLATION ..... 3-5  
 CAB FEATURES & OPERATION..... 6  
 CARE AND MAINTENANCE..... 6  
 SERVICE PARTS ..... 7  
 BOLT TORQUE SPECIFICATIONS ..... 8-9

## WARNINGS, TIPS, & REQUIRED TOOLS

Curtis cabs, kits, and accessories feature an assembly of parts designed for your vehicle which require adjustment and alignment of components to accommodate vehicle variations and provide proper weather protection. For accurate installation, proper operation, and years of satisfaction, please read and understand the installation and owner's manual fully prior to installing the door kit.

From all of us at Curtis, we thank you for choosing our product.



**ADDED WEIGHT NOTICE**

Curtis Cabs, blades and general accessories add additional weight to the base vehicle. All Curtis accessory weights are listed in product brochures. Deduct the accessory's total weight from the vehicle's rated capacity and never exceed the vehicle's rated capacity including driver and passenger.

**WARNING** Exposure to Carbon Monoxide can Cause illness, serious injury or death. Never operate vehicle if suspicious of Carbon Monoxide. Inspect exhaust system for leaks monthly. Leaks can result from loose connections, corrosion, cracks or other damage to the exhaust manifold. If leaks are found, repair or replace exhaust system. Do not use vehicle until repair or replacement is complete.

**WARNING**

**Serious Injury or Death**

	This cab enclosure does not provide protection from rollover or other accidents.
	This cab enclosure does not provide protection from flying objects including golf balls.
	This cab enclosure does not provide protection from lightning. When lightning threatens take cover and do not operate vehicle.

**California Health and Safety Proposition 65 Warning:** This product may contain chemicals known to the state of California to cause cancer and birth defects or other reproductive harm.

## GENERAL INFORMATION BEFORE YOU START

### HELPFUL HINTS:

- Refer to parts diagram found in the service parts section of this manual to help identify parts during the assembly process.
- To assist with the door installation, leave all fasteners loose for later adjustment unless otherwise specified.
- Read and understand all instructions before beginning.
- Apply a silicone sealant to seal any minor gaps that may occur due to vehicle variations.
- Before installing parts with factory installed rubber, make sure the rubber is fully installed onto the parts for proper fit and sealing.

### TOOLS REQUIRED:

- Set of Standard and Metric Sockets (3/8" Drive)
- 3/8" Drive Ratchet and Long Drive Extension
- Set of Standard and Metric Open-End Wrenches
- Silicone Sealant
- Drill/Driver
- Torque T40 Wrench

# KIT INSTALLATION

## STEP 1: (VEHICLE PREP)

If installing multiple Curtis Polaris Ranger 1000 kits, install in the following order.

- 1.Doors
- 2.Windshield
- 3.Rear Panel
- 4.Roof

If the vehicle's nets are not installed on your vehicle, skip to Step 1.6 on the next page.

- 1.1 Per figure 1.1, remove left lower, mount-net and its (2) mounting screws. Re-install screws into the vehicle.

**Tools required**

Torque T40 wrench or socket

- 1.2 Per figure 1.2, remove left net clip and its (2) mounting screws.

**Tools required**

Torque T40 wrench or socket

- 1.3 Per figure 1.3, remove (2) of the left net mounting screws. The screws are located in the shoulder restraint top mounting foot and the bottom of the door opening. Re-install screws into the vehicle with the net mount removed.

**Tools required**

Torque T40 wrench or socket

- 1.4 Per figure 1.4, remove hex flange mounting screw at the shoulder restraint bottom mounting foot. Re-install screw into the vehicle with the net mount removed.

**Tools required**

13mm socket and wrench

- 1.5 Per figure 1.5, remove hex flange mounting screw and hinge plate at the back of the ROPS. The net is now free to be completely removed.

**Tools required**

13mm socket and wrench



Fig. 1.1 (Remove Left Lower, Mount-Net)



Fig. 1.2 (Remove Left Net-Clip)

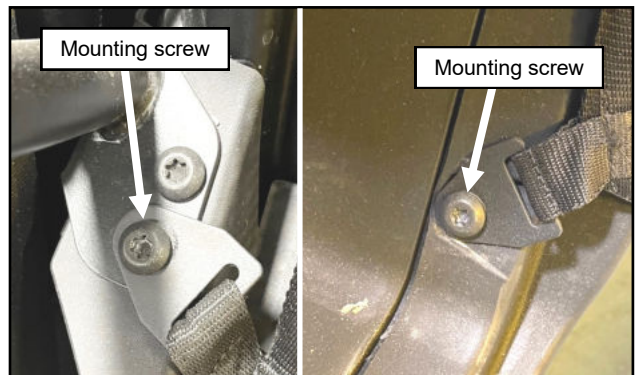

Fig. 1.3 (Remove Left Net Mounting Screws)

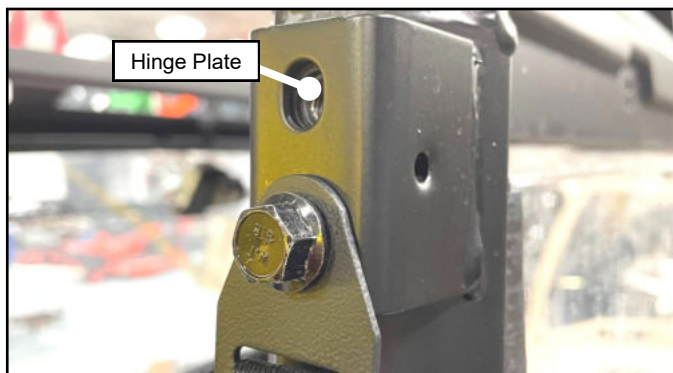

Fig. 1.5 (Remove Top Left Net Mounting Screw)



Fig. 1.4 (Remove Left Net Mounting Screw)

# KIT INSTALLATION

## STEP 1: (VEHICLE PREP, continued)

- 1.6 Use black silicone to seal the entire front ROPS joint shown in Figure 1.6. **Note: A significant amount of water will enter the vehicle through this seam if this step is not taken.**
- 1.7 Repeat steps 1.1 to 1.6 on right side net assembly

## STEP 2: (KIT INSTALLATION)

- 2.1 Per figure 2.1, install striker pin assembly on the left side at the removed net-clip location. Use provided M8 hex flange bolts.

**Hardware Used** **Qty**  
M8x1.25 X 30 Hex Head Flange Screw 2

**Tools required**  
13mm socket and wrench

- 2.2 Per figure 2.2, install upper left hinge pin on the left side ROPS . Use provided 5/16-18 hex flange bolts and (1 of 4) hinge pin mounting plates.

**Hardware Used** **Qty**  
5/16-18 X 3/4 Hex Head Flange Screw 2

**Tools required**  
1/2" socket and wrench

- 2.3 Per figure 2.3, install lower left hinge pin on the left side ROPS . Use provided 5/16-18 hex flange bolts and (1 of 4) hinge pin mounting plates.

**Hardware Used** **Qty**  
5/16-18 X 3/4 Hex Head Flange Screw 2

**Tools required**  
1/2" socket and wrench

- 2.4 Install the supplied brass washers onto the hinge pins on the left side and then apply grease to the pins.



Fig. 1.6 (ROPS Joint)



Fig. 2.1 (Striker Pin Assembly, Left)

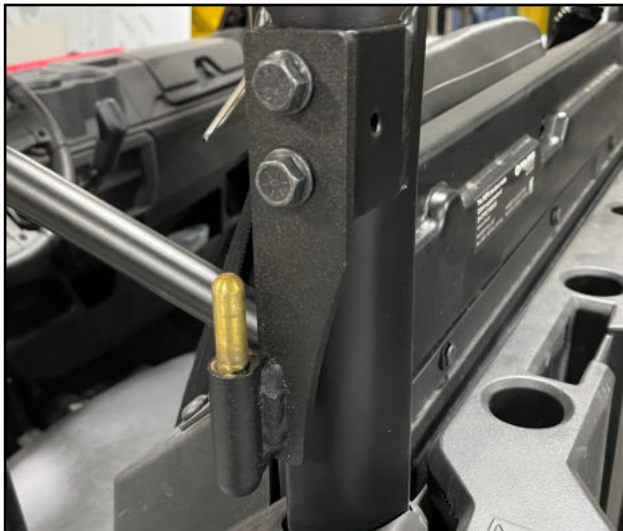

Fig. 2.3 (Lower Hinge Pin, Left)



Fig. 2.2 (Upper Hinge Pin, Left)

# KIT INSTALLATION

## STEP 2: (KIT INSTALLATION CONT'D)

**2.5** See figures 2.5a & 2.5b. Loosen the door hinges to allow for adjustment later. Hang the left door on the hinges. While lifting up and forward on the door handle, line up the door latch with the striker pin and carefully attempt to latch. You should be able to hear 2 clicks as you slowly engage the latch on the pin. If the latch is too far forward or back to latch on the pin, adjust as shown. Then retighten and latch.

### Tools required

3/8" socket and wrench  
7/16" socket and wrench

**2.6** Stand back and examine the alignment of the door with the roof and the vehicle's A-pillar. You can adjust this by moving the striker pin up or down as shown to help with alignment. TIP: In the final step, the front of the door will drop a small amount the first time you open it. Set the front of the door a little bit higher so it aligns properly. Adjust as necessary until you are happy with the alignment. Once more carefully close the door like you did in step 2.5. Tighten the hinge bolts.

### Tools required

3/8" socket and wrench  
7/16" socket and wrench  
13mm socket and wrench

**2.7** Open the door and check for smooth operation of the latch. As noted in step 2.6, the door will likely drop a little bit at the front and the striker pin will need to be adjusted down accordingly. Also make sure the door seal is making contact along the perimeter of the door and the latch clicks twice when closing. If necessary, adjust the striker in or out to achieve this (see Figure 2.6).

**2.8** Due to vehicle and cab manufacturing tolerances, the door frames may need to be hand bent to improve the seal.

To adjust the bottom of the door, hold the door at the latch with the door open and have an assistant hold the top of the door. Pull inward on the bottom corner of the door, then close the door and check the seal.

To adjust the top of the door, hold the door at the latch with the door open and pull inward on the top corner. It is not necessary to have an assistant hold the bottom.

Repeat as needed until the door is sealed around the entire perimeter.

**2.9** Repeat steps 2.1 through 2.8 for the right door.

**2.10** Kit is now fully installed.

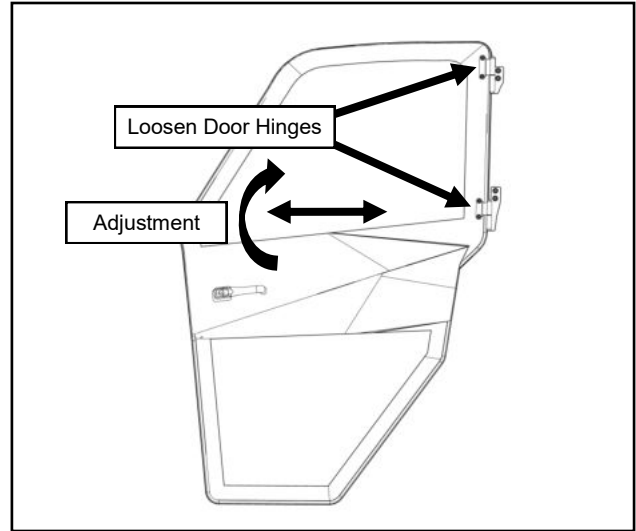

Fig. 2.5a (Door Hinge Adjustment, Left)

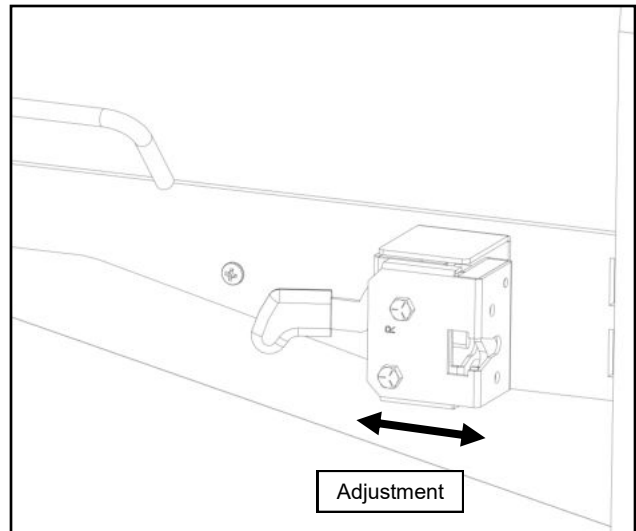

Fig. 2.5b (Door Latch Adjustment, Left)

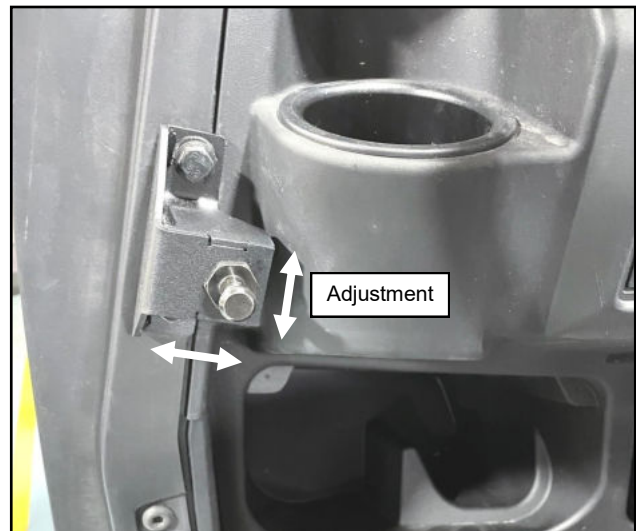

Fig. 2.6 (Striker Pin Adjustment, Left)

## KIT FEATURES & OPERATION

### LIFT-OFF DOORS

For added ventilation, the doors on the Ranger 1000 door kit lift off in seconds without tools.

To lift off:

1) Rotate the doors 90° to the ROPS and lift. Also, remove the hinge washers and store in a plastic bag. *Store the doors in a safe location to prevent damage.*



Lift-Off Door

## CARE AND MAINTENANCE

- Re-apply lubrication (preferably grease) periodically as needed to the door striker pins, door latch assemblies, and the door hinges.
- Check and tighten hardware after 40 hours of operation. Periodically inspect and tighten hardware for the remainder of the unit's life.
- Vinyl components should be washed with a mild solution of warm soapy water.
- Clear vinyl can be easily scratched. Keep curtain clean.

# POLARIS RANGER 1000 DOOR KIT SERVICE PARTS

DOOR, LEFT  
P/N: 8SV-107-00045-L



DOOR CURTAIN, LEFT  
P/N: 8SV-112-00062-L



DOOR HINGES (SLEEVE)  
P/N: 8SV-WA-00458-L & 8SV-WA-00458-R

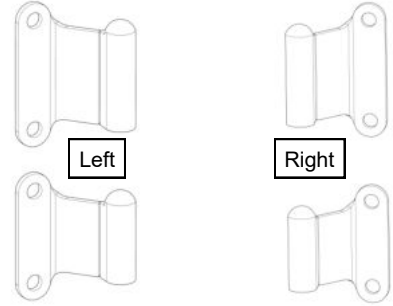

DOOR, RIGHT  
P/N: 8SV-107-00045-R



DOOR CURTAIN, RIGHT  
P/N: 8SV-112-00062-R



SET OF HINGE PIN MOUNTING PLATES (4)  
P/N: 8SV-WA-00462

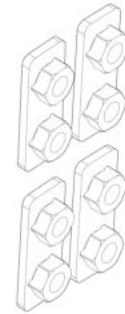

HINGE PIN SET, LEFT  
P/N: 8SV-WA-00459-L



HINGE PIN SET, RIGHT  
P/N: 8SV-WA-00459-R

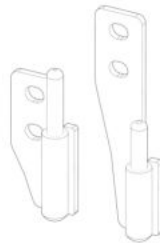

STRIKER PIN ASSEMBLY  
P/N: 8SV-113-00250

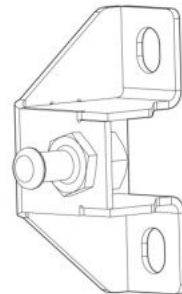

5/8" SIDE BULB  
W/ 1/4" GRIP, 15'

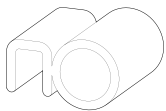

9SV-PR23-15

# Torque Specs. for Structural Bolts

This page is for use primarily when dealing with high-strength vehicle fasteners such as ROPS hardware that hold the structure together for safety. This page can also be used for other solid metal-to-metal joints. **Do not** use these high torque values on any of the following applications involving: tubing, plastic, nylon or rubber washers, threaded inserts, etc.. See next page regarding less critical fasteners.

The values below apply to fasteners that are dry or lubricated with normal engine oil. They do not apply if special graphited or moly disulphide greases or other extreme pressure lubricants are used. This applies to both UNF and UNC threads. Remember to always use the same grade or property class when replacing bolts.

**IMPORTANT: on all PLATED GRADE 8 bolts, reduce torque 15% from listed bolt torque specification.**

SAE Grade No.		2				5				8*				
Bolt head identification mark as per grade. NOTE: Manufacturing Marks Will Vary														
		TORQUE		TORQUE		TORQUE		TORQUE		TORQUE		TORQUE		
Bolt Size	Inches	Millimeters	Pounds Feet		Newton-Meters		Pounds Feet		Newton-Meters		Pounds Feet		Newton-Meters	
			Min.	Max.	Min.	Max.	Min.	Max.	Min.	Max.	Min.	Max.	Min.	Max.
1/4	6.35	5	6	7	8	9	11	12	15	12	15	16	20	
5/16	7.94	10	12	14	16	17	20.5	23	28	24	29	33	39	
3/8	9.53	20	23	27	31	35	42	48	57	45	54	61	73	
7/16	11.11	30	35	41	47	54	64	73	87	70	84	95	114	
1/2	12.70	45	52	61	70	80	96	109	130	110	132	149	179	
9/16	14.29	65	75	88	102	110	132	149	179	160	192	217	260	
5/8	15.88	95	105	129	142	150	180	203	244	220	264	298	358	
3/4	19.05	150	185	203	251	270	324	366	439	380	456	515	618	
7/8	22.23	160	200	217	271	400	480	542	651	600	720	814	976	
1	25.40	250	300	339	406	580	696	787	944	900	1080	1220	1464	
1-1/8	25.58	-	-	-	-	800	880	1085	1193	1280	1440	1736	1953	
1-1/4	31.75	-	-	-	-	1120	1240	1519	1681	1820	2000	2468	2712	
1-3/8	34.93	-	-	-	-	1460	1680	1980	2278	2380	2720	3227	3688	
1-1/2	38.10	-	-	-	-	1940	2200	2631	2983	3160	3560	4285	4827	

\*Thick Nuts must be used with Grade 8 bolts

## METRIC BOLT TORQUE SPECIFICATIONS



Size of Screw	Property Class	Course Thread			Fine Thread		
		Pitch (mm)	Pounds Feet	Newton-Meters	Pitch (mm)	Pounds Feet	Newton-Meters
M6	5.6	1.0	3.6-5.8	4.9-7.9	-	-	-
	8.8		5.8-9.4	7.9-12.7		-	-
	10.9		7.2-10	9.8-13.6		-	-
M8	5.6	1.25	7.2-14	9.8-19	1.0	12-17	16.3-23
	8.8		17-22	23-29.8		19-27	25.7-36.6
	10.9		20-26	27.1-35.2		22-31	29.8-42
M10	5.6	1.5	20-25	27.1-33.9	1.25	20-29	27.1-39.3
	8.8		34-40	46.1-54.2		35-47	47.4-63.7
	10.9		38-46	51.5-62.3		40-52	54.2-70.5
M12	5.6	1.75	28-34	37.9-46.1	1.25	31-41	42-55.6
	8.8		51-59	69.1-79.9		55-68	75.9-92.1
	10.9		57-66	77.2-89.4		62-75	84-101.6
M14	5.6	2.0	49-56	66.4-75.9	1.5	52-64	70.5-86.7
	8.8		81-93	109.8-126		90-106	122-143.6
	10.9		96-109	130.1-147.7		107-124	145-168
M16	5.6	2.0	67-77	90.8-104.3	1.5	69-83	93.6-112.5
	8.8		116-130	157.2-176.2		120-138	162.6-187
	10.9		129-145	174.8-196.5		140-158	189.7-214.1
M18	5.6	2.0	88-100	119.2-136	1.5	100-117	136-158.5
	8.8		150-168	203.3-227.6		177-199	239.8-269.6
	10.9		175-194	237.1-262.9		202-231	273.7-313
M20	5.6	2.5	108-130	146.3-176.2	1.5	132-150	178.9-203.3
	8.8		186-205	252-277.8		206-242	279.1-327.9
	10.9		213-249	288.6-337.4		246-289	333.3-391.6

## Tightening of Non-Structural Bolts

For light or medium duty fastening, Curtis recommends using a general industry standard of tightening until snug and then giving an additional one quarter turn of the tool as deemed reasonable for the application (i.e.: at the installer's discretion).

If torque values are required, the examples listed below are intended as a reasonable reference for use in the majority of non-structural fastener applications such as: small diameter fasteners; bolts passing thru tubing, glass, plastic, nylon or rubber washers, threaded inserts, etc.

If more than one application below applies, use the lower torque value.

FASTENER SIZE:	FASTENER TYPE:	WASHER MATERIAL:	APPLICATION:	TORQUE (INCH-POUNDS) (±5)
#10	Machine Screws	-	in Nylon P-Clamps	20
#10	Machine Screws	-	Strobe Light (plastic base)	35
M5	Set Screws	-	Wiper Arm	20
1/4"	Cap Nut	-	Windshield Wiper	20
1/4"	Bolts	-	Tubing (5/8" to 3/4" wide)	132
1/4"	Bolts	Rubber	-	60
1/4"	Bolts	Nylon / Plastic	-	72
1/4"	Bolts	-	Factory Installed Threaded Inserts	132
5/16"	Bolts	-	Tubing (1" or wider)	60
5/16"	Flat Head Bolts	-	Plastic Windshield Hinge	79
5/16"	Bolts	Rubber	-	120
5/16"	Bolts	Nylon / Plastic	-	150
5/16"	Ball Studs	-	-	150
5/16"	Bolts	-	Factory Installed Threaded Inserts	240
3/8"	Bolts	-	Tubing	120
M12	Door Striker Pins	-	-	120