



9LEDW1 Work Light ROPS-Mount Kit

The contents of this envelope are the property of the owner.
Be sure to leave with the owner when installation is complete.

APPROXIMATE INSTALLATION TIME: 20 Minutes

INSTALLING THE WORK LIGHT KIT

- A. Attach the work light mounting bracket to the ROPS (Roll-Over Protective Structure) using the appropriate U-bolt from the hardware kit and two locknuts from the hardware kit.
- NOTE: For mounting to square or rectangular tubing, apply the supplied 1/8" x 1" foam tape per Fig. 1.
For mounting to round tubing, use the rubber spacer from the hardware kit per Fig. 2.
- B. Per Fig. 3, insert the large grommet on the wire harness into the cover, insert the tabs of the cover into the slots in the mounting bracket and slide the cover up into the bracket until the hole in the cover lines up with the slot in the bracket.
 - C. Secure the cover to the bracket with a sheet metal screw from the hardware kit.
 - D. Use cable ties to secure the wire harness to the ROPS, and feed the free end of the harness along the ROPS toward the nearest enclosed structure (rear panel, under seat compartment, underside of rear fenders, etc.)
 - E. Connect the light to power per the wiring diagram below.

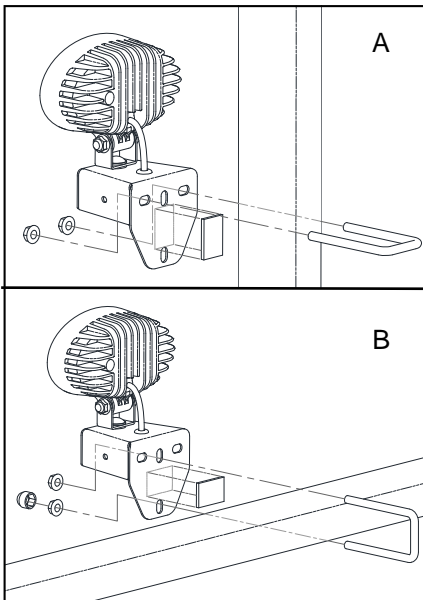

Fig. 1 (rectangular / square bar)

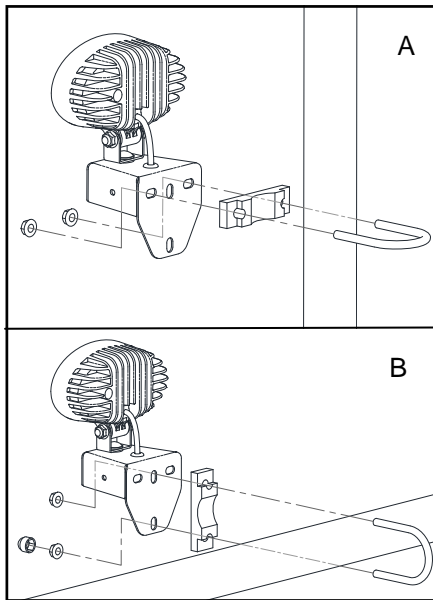

Fig. 2 (round bar)

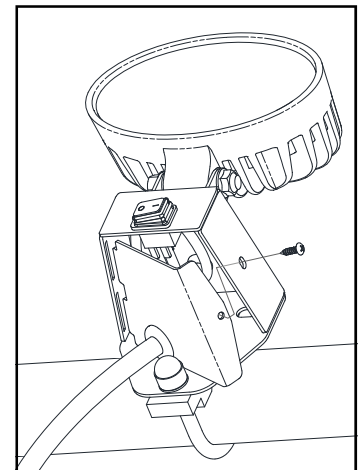
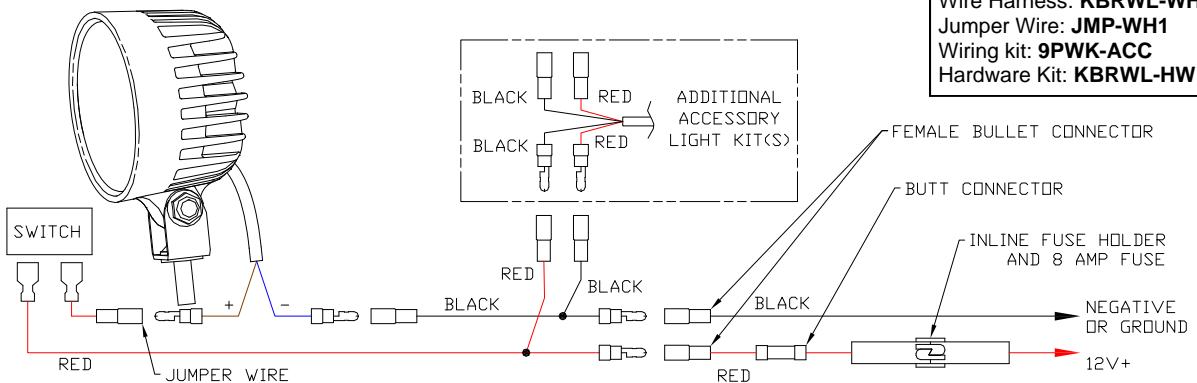

Fig. 3 (cover installation)

Service parts:
 Light: **9LEDO** 3x5 inch oval work light
 Bracket: **KBRWL-01**
 Cover: **KBRWL-02**
 Switch: **9RSM**
 Wire Harness: **KBRWL-WH1**
 Jumper Wire: **JMP-WH1**
 Wiring kit: **9PWK-ACC**
 Hardware Kit: **KBRWL-HWK**



Rev. C
6/11/2014