



INSTALLATION & OWNER'S MANUAL

John Deere Gator TS Windshield Kit p/n:1WS1A

Canopy Kit (p/n: 1CT2A) is required for the installation of this kit

The contents of this envelope are the property of the owner. Be sure to leave with the owner when installation is complete.

APPROXIMATE INSTALLATION TIME: 1/2 HOUR

TOOLS REQUIRED: Rubber mallet

ADDED WEIGHT NOTICE
Curtis Cabs, blades and general accessories add additional weight to the base vehicle. All Curtis accessory weights are listed in product brochures. Deduct the accessory's total weight from the vehicle's rated capacity and never exceed the vehicle's rated capacity including driver and passenger.

! WARNING: Remove windshield before transporting on an open trailer!



PARTS IN KIT

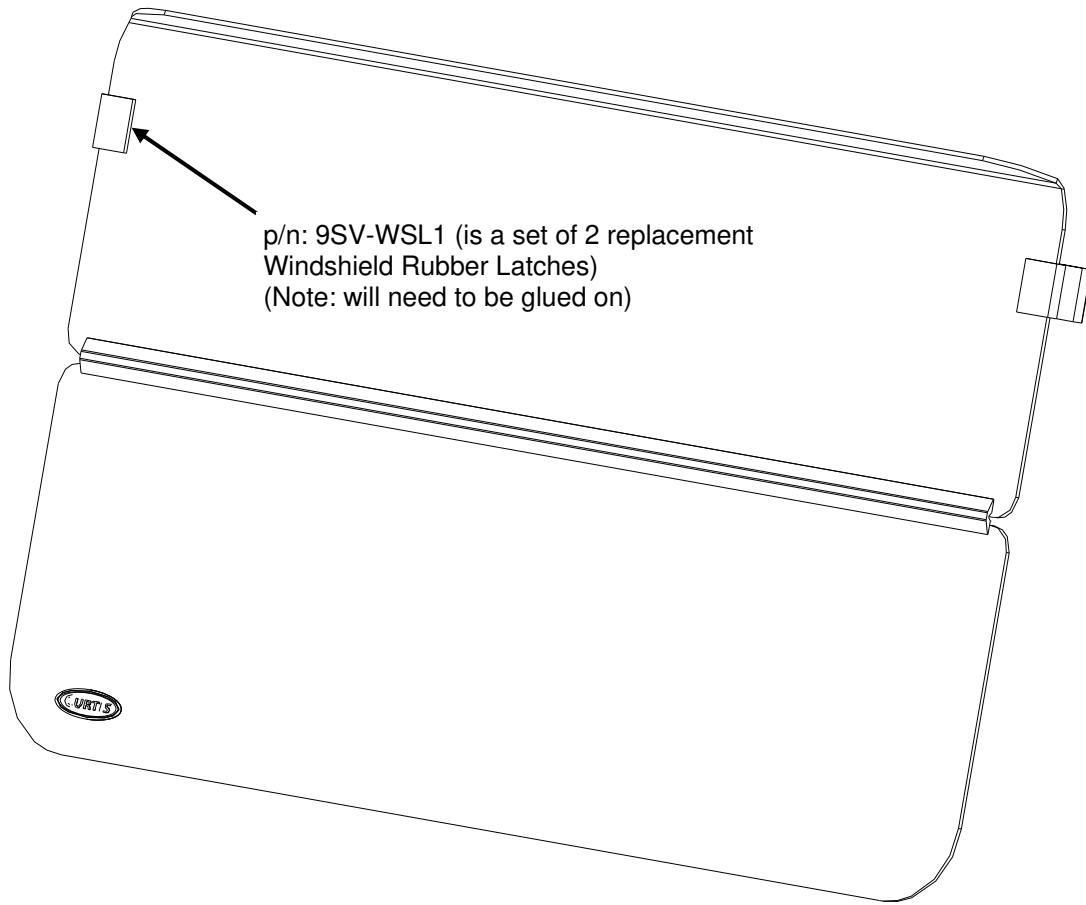

p/n: 9SV-WSL1 (is a set of 2 replacement
Windshield Rubber Latches)
(Note: will need to be glued on)

HARDWARE BAG (9SV-JG411MK)



INSTRUCTIONS

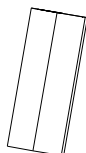
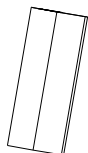

Step 1 Assembly

- 1.1** Peel the plastic back from the sides and bottom of the windshield.
- 1.2** Per figure 1.2, position the windshield clips in the approximate center of the sides of the lower window. Use the rubber mallet to seat the clip within an 1/8" of the edge of the windshield.
- 1.3** Per figure 1.3, install both windshield latch clips on the bottom of the lower windshield, approximately 7" in from the sides. Seat fully with rubber mallet.

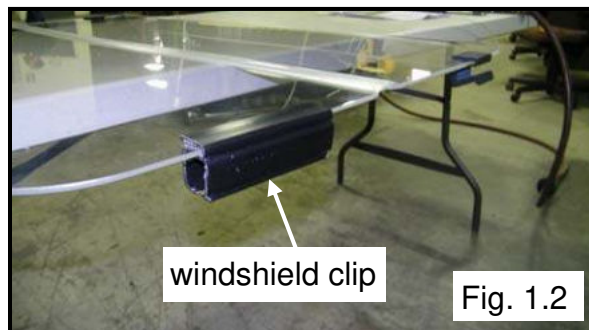

Fig. 1.2

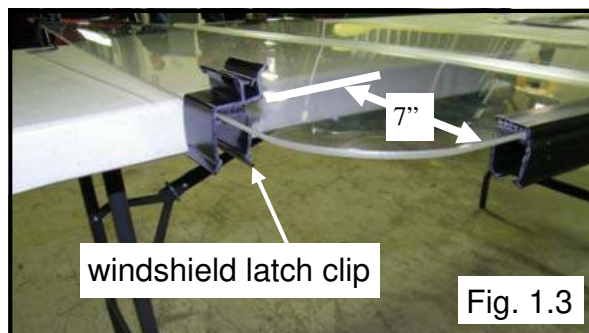

Fig. 1.3

Step 2 Installation

- 2.1** Fold the upper windshield over and press the upper flange into the latch clips on the lower windshield.
- 2.2** Per figure 2.2, position the windshield over the canopy front support tube structure and snap the latch clips and side clips over the tubing.
- 2.3** Unfold the upper windshield and use the rubber latches to secure to the canopy front support in the closed position.

Note: If the top of the windshield contacts the canopy, push straight up on the front edge of the canopy near each corner. The holes in the canopy allow for a lot of adjustment between the supports and the canopy.

⚠ WARNING: Remove windshield before transporting on an open trailer!



Fig. 2.2

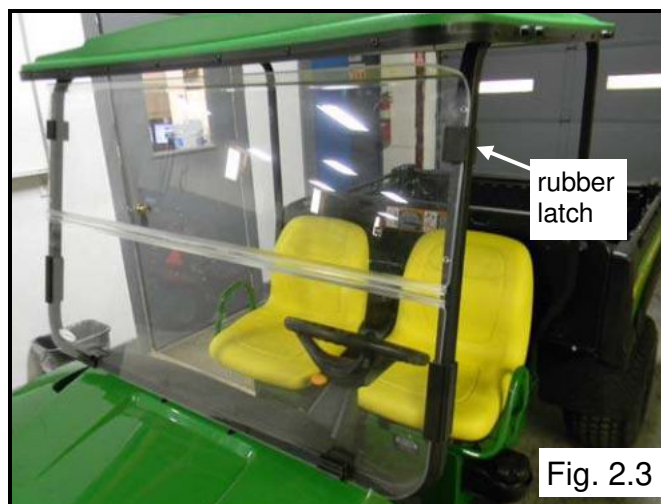

Fig. 2.3



John Deere Gator TS Canopy
p/n: 1CT2A

An optional windshield may be purchased for use with the canopy (p/n: 1WS1A)

The contents of this envelope are the property of the owner.
Be sure to leave with the owner when installation is complete.

APPROXIMATE INSTALLATION TIME: 1 HOUR

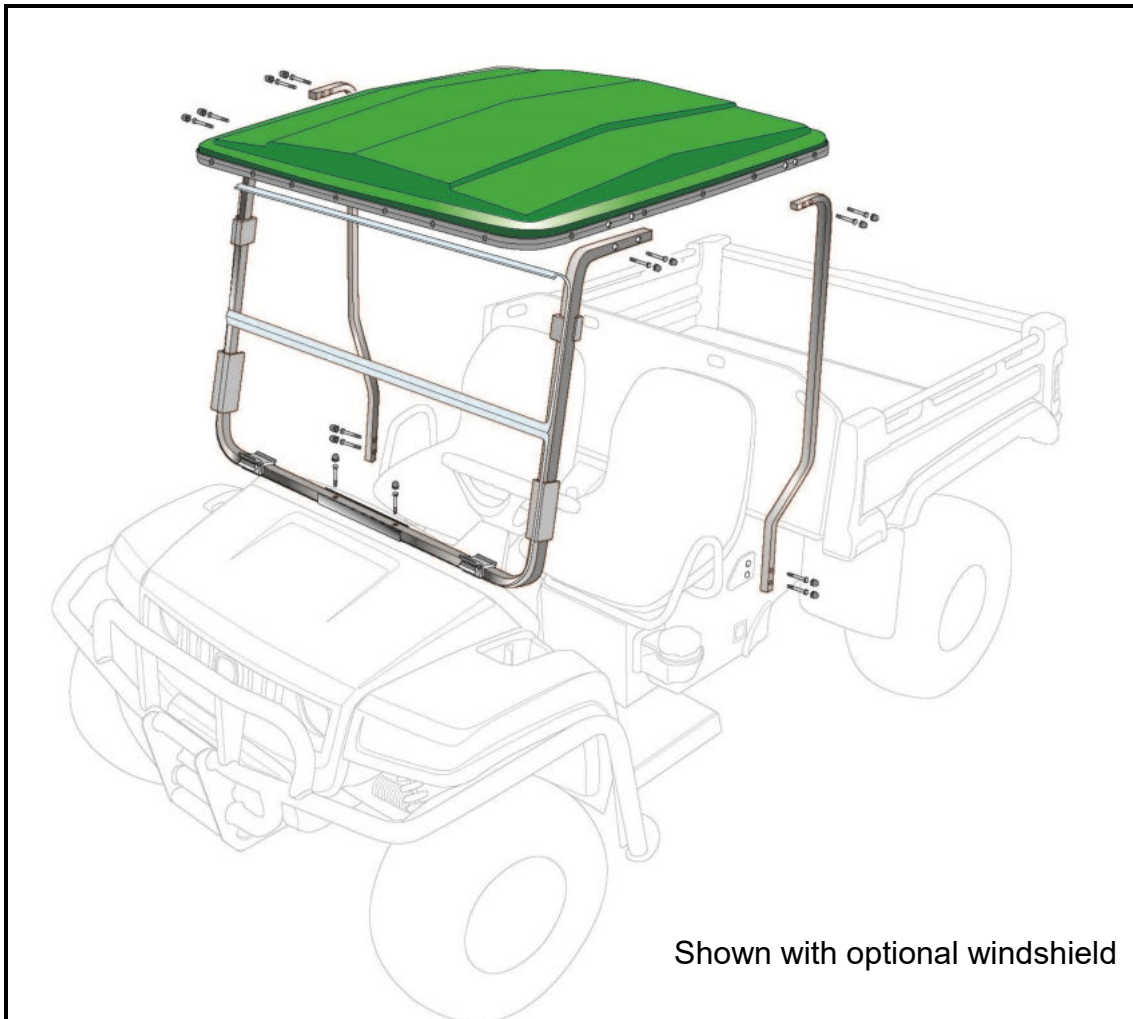

Shown with optional windshield

PARTS IN KIT

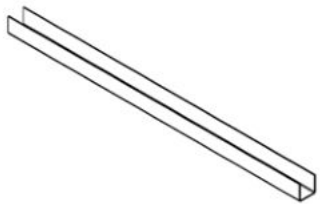

JG21C
Front Support Channel

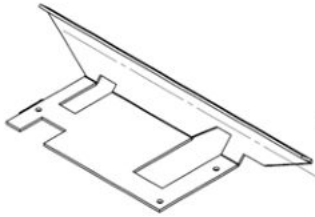

JG21B
Front Bracket

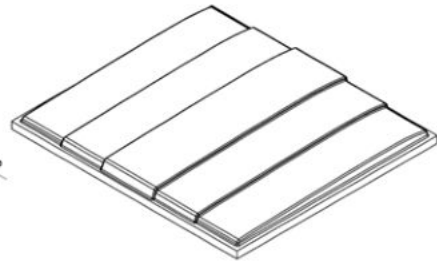

JG21GC
Canopy

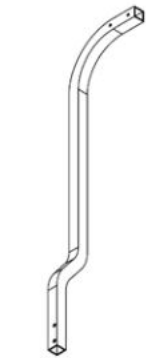

JG21D
Driver's Side
Rear Support

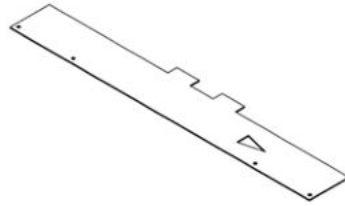

Template

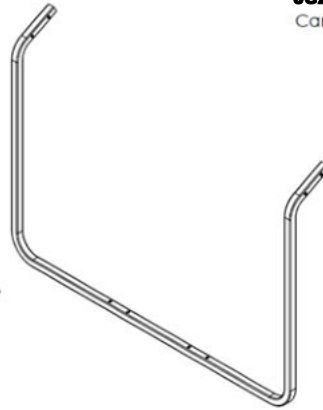

JG21F
Front Support



JG21P
Passenger's Side
Rear Support

JG21H



2 - Rear
Support Gaskets

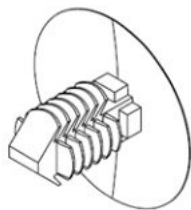

2 - Christmas
Tree Plugs

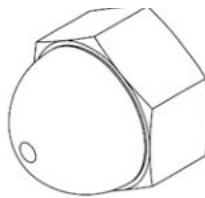

2 - Acorn Nuts

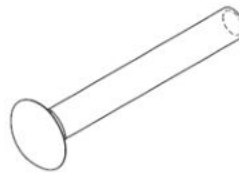

2 - 5/16"-18 x 2.5"
Carriage Bolts

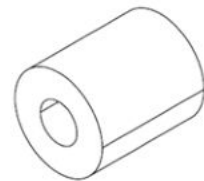

2 - Aluminum Spacers



8 - 1/4" Lock
Washers



11 - 1/4" Flat
Washers



4 - 5/16" Sealing
Washers



8 - 3/8" Sealing
Washers

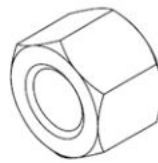

3 - 1/4"-20
Lock Nuts

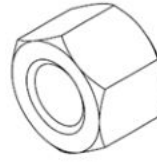

2 - 5/16"-18
Lock Nuts

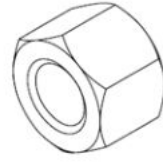

4 - 3/8"-16
Lock Nuts

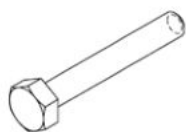

3 - 1/4"-20 x 1.75"
Hex Head Bolts

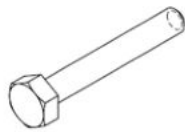

4 - 3/8"-16 x 2.5"
Hex Head Bolts

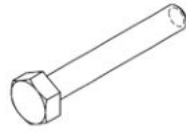

4 - 1/4"-20 x 2" Hex Head
Bolts with Loctite

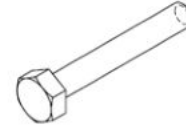

4 - 1/4"-20 x 1.5" Hex Head
Bolts with Loctite

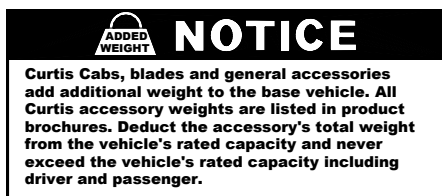

HELPFUL HINTS:

- Refer to parts diagram found on page 2 of this manual to help identify parts during the assembly process.
- To assist with the installation, leave all fasteners loose for later adjustment unless otherwise specified.
- Read and understand all instructions before beginning.
- Separate hardware before beginning. Note that there are different size sealing washers.

TOOLS REQUIRED:

- Ratchet
- 7/16", 1/2", and 9/16" sockets
- 7/16" and 9/16" wrenches
- Drill
- 9/32" and 5/8" drill bits

Step 1: Prepare Vehicle

1.1 Locate the triangles on the bottom outside corners of the hood. Pull to release the clips and lift the hood up and off the Gator.



Figure 1.1A



Figure 1.1B

1.2 Place the paper template on the top of the hood with the arrow pointing towards the driver's side. Line up the tabs on the paper with the corresponding tabs on the hood. Secure the template in place and mark the location of the holes. Use the widest hole spread the front support allows for.

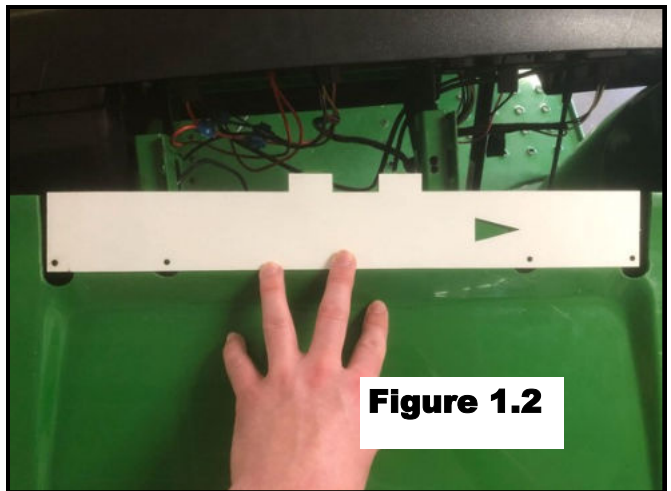

Figure 1.2

1.3 Drill two 5/8" holes through the hood in the marked locations. Slot the holes towards the rear of the vehicle.



Figure 1.3

Step 2: Install Front Bracket

2.1 Place the front bracket down and push all the way to the right so that the tab on the left side of the front bracket is flush with the frame of the Gator. Then slide upwards so the cutout on the left side of the front bracket hits the vertical flange on the Gator frame. Secure the bracket in place and then mark the hole locations.



2.2 Drill 9/32" holes in the rails in the marked locations. CAUTION! Ensure that the wires are out of the way before drilling.

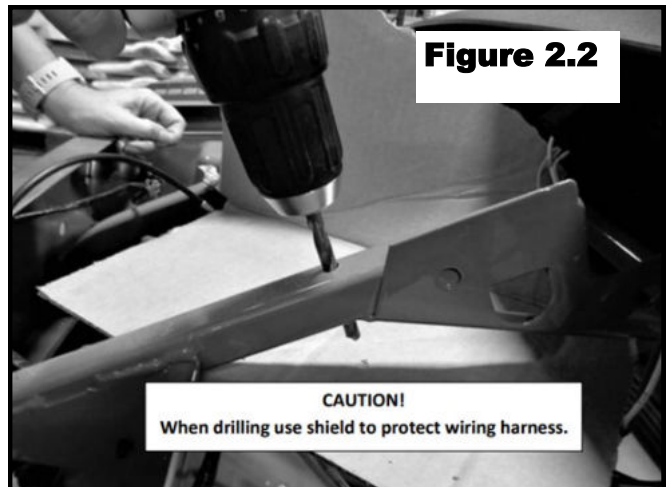

2.3 Use the 1/4-20 x 1 3/4" long bolts, 1/4" flat washers, and 1/4-20 locknuts to secure the front bracket in place.

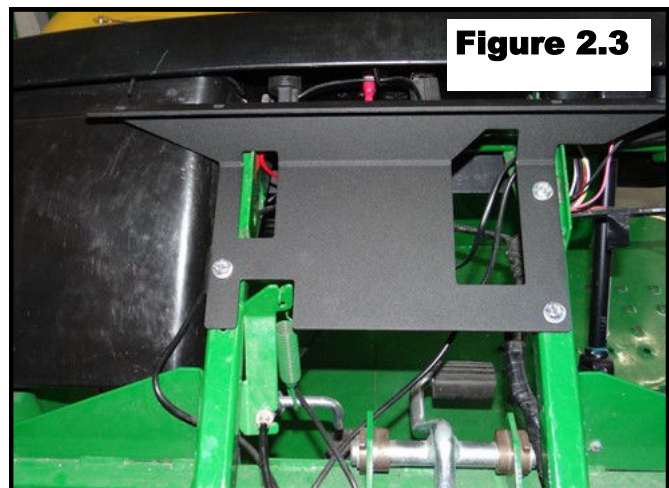

Step 3: Install Front Support

3.1 Place the carriage bolts up through the front bracket in the holes corresponding to the hole spread drilled on the hood. Place a spacer on each carriage bolt and a **5/16" sealing washer, rubber side up**, on top of the spacer.

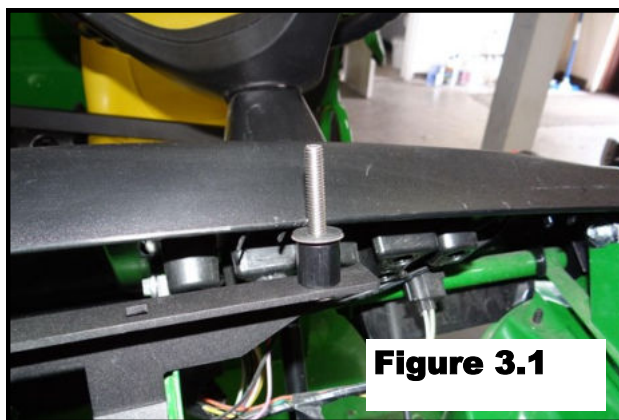

3.2 Next, install the front support channel over the washers.



3.3 Install the front support over the studs. Secure the support with a pair of **5/16" sealing washers, rubber side down**, then use 5/16" locknuts. Do not completely tighten the nuts until the canopy is installed. Cover the exposed studs with the black acorn nuts after securing the nuts.

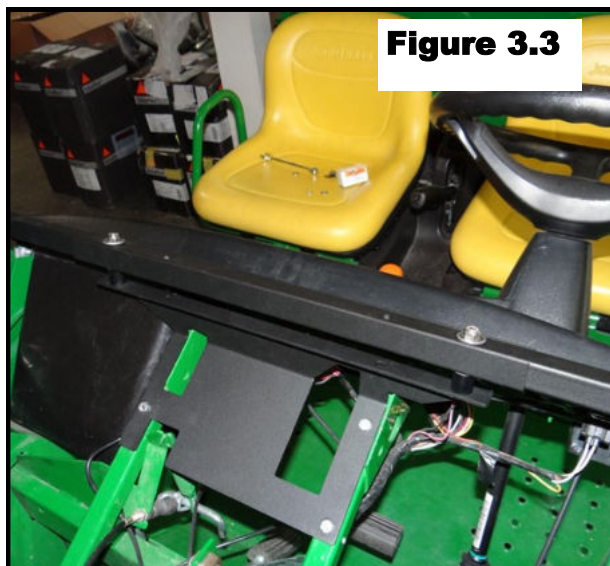

Step 4: Install Rear Supports

4.1 Locate the green triangle that is below the seats, you may have to tilt the seat forward to access this area.

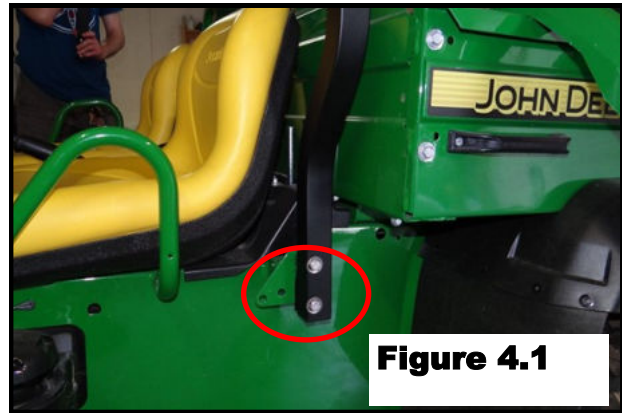

Figure 4.1

4.2 Use a 3/8" bolt and a 3/8" sealing washer on the outside of the rear support. Place the PVC gasket on the backside of the rear support and fasten to the triangular bracket with a 3/8" sealing washer and a 3/8" locknut on the backside of the bracket.

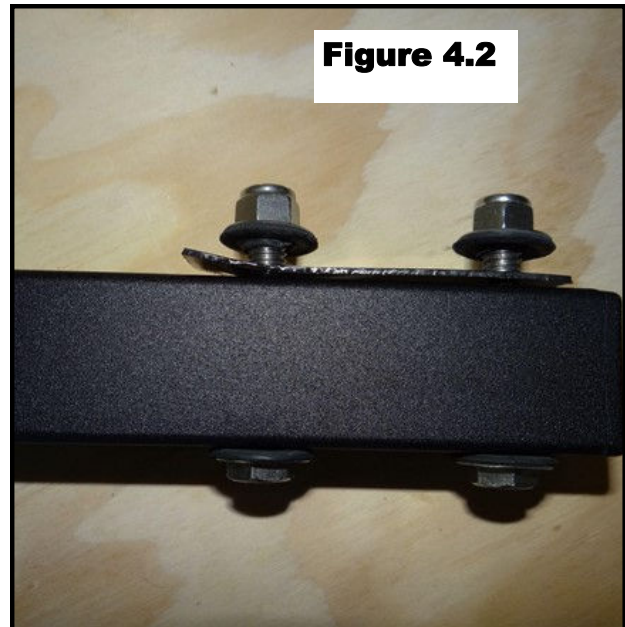

Figure 4.2

4.3 Secure the supports, but do not tighten all the way. Repeat this process for the other side's support and tilt the seats back if necessary. Make sure the rear supports are perpendicular to the ground.



Figure 4.3

Step 5: Install Canopy

5.1 Locate the seam on the black band around the canopy top and position the canopy with the seam side towards the rear of the vehicle. Line up the rear supports with the corresponding pocket in the canopy.

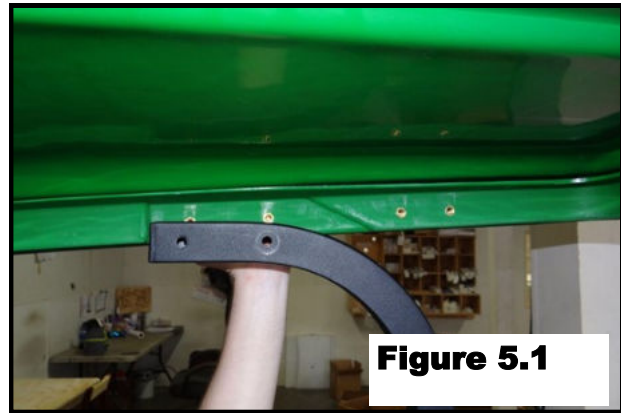

5.2 Secure the front support to the canopy using four 1/4-20 x 1.5" long Loctite bolts, lock washers, and flat washers. Secure the rear supports to the canopy using four 1/4-20 x 2" long Loctite bolts, lock washers, and flat washers.

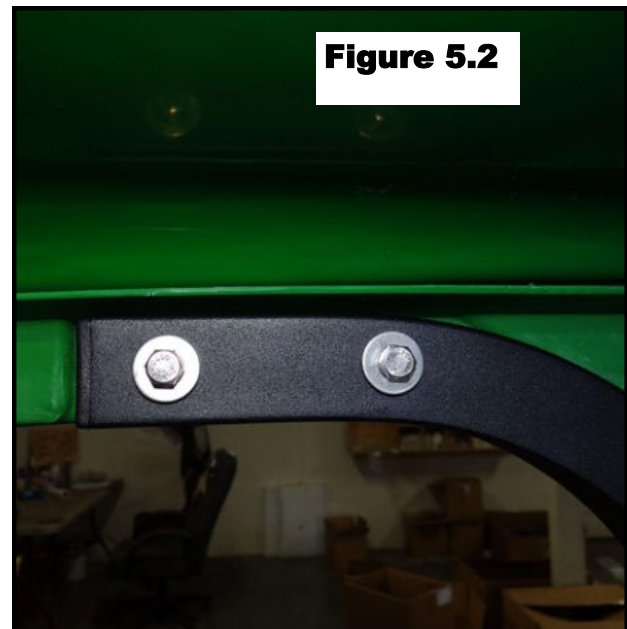

Step 6: Re-Install Hood

6.1 Line up the slots on the hood with the carriage bolts on the front bracket.



6.2 Slowly lower the hood over the exposed studs until it latches back in place. The hood may need to be bent slightly to fit over the studs. When the hood is returned to its position, make sure that both the studs and the nuts are exposed.



Step 7: Finishing Touches

7.1 Tighten all bolts. As a reminder, do not use power tools to secure any of the bolts.

7.2 Install the 2 Christmas tree plugs.