



New Holland Workmaster 25S Cab with Heater (p/n: 1NHWM25SCA) fits tractor models: Workmaster 25S

While this cab kit was designed to fit on the vehicle(s) listed above, manufacturing tolerances and vehicle assembly may affect cab fitment. It is the responsibility of the cab installer to check all vehicle pedals and levers for full functionality and, as required, adjust the cab fitment to prevent any interference of the cab components with the travel of pedals or levers.



- Available Options:
1. Front LED Work Lights (P/N: 9LEDW4)
 2. Rear LED Work Lights (P/N: 9LEDW3)
 3. Strobe Light (P/N: 9LEDS2)
 4. Dome Light (P/N: 9LEDD14)
 5. Side View Mirrors (P/N: 9PM5)
 6. Rear View Mirror (P/N: 9PM3)
 7. Rear Wiper (P/N: 9PWK8512F9-11A)
 8. Seal Kit (P/N: 9SK8)
 9. Adaptor Kit to Mount Cab Without Loader (P/N: 1NHWM25SAK)

Approximate Installation Time *
Experienced Dealer Technician – 6 Hours
Average Dealer Technician – 8 Hours
Do-It-Yourself – 10 Hours

(* = Not including accessories)

Approximate Product Specifications
Floorboard to Roof Height: 61.625 inches
Weight: 329 lbs.
Cab Width: 47.625 inches (w/o side mirrors)

The contents of this envelope are the property of the owner. Leave with the owner when installation is complete.

TABLE OF CONTENTS

WARNINGS, TIPS, & REQUIRED TOOLS.....	3
CAB INSTALLATION.....	4-18
CAB FEATURES & OPERATION.....	19-20
CARE AND MAINTENANCE.....	21
SERVICE PARTS	22-25
OPTIONAL ACCESSORIES	26
TORQUE SPECIFICATIONS	27-28





WARNINGS, TIPS, & REQUIRED TOOLS

Curtis cabs feature an assembly of parts designed for your vehicle which require adjustment and alignment of components to accommodate vehicle variations and provide proper weather protection. For accurate installation, proper operation, and years of satisfaction, please read and understand the installation and owner's manual fully prior to installing the cab.

From all of us at Curtis, we thank you for choosing our product.

 NOTICE
<p>Curtis Cabs, blades and general accessories add additional weight to the base vehicle. All Curtis accessory weights are listed in product brochures. Deduct the accessory's total weight from the vehicle's rated capacity and never exceed the vehicle's rated capacity including driver and passenger.</p>

<p>WARNING Exposure to Carbon Monoxide can Cause illness, serious injury or death. Never operate vehicle if suspicious of Carbon Monoxide. Inspect exhaust system for leaks monthly. Leaks can result from loose connections, corrosion, cracks or other damage to the exhaust manifold. If leaks are found, repair or replace exhaust system. Do not use vehicle until repair or replacement is complete.</p>

 WARNING	
Serious Injury or Death	
	This cab enclosure does not provide protection from rollover or other accidents.
	This cab enclosure does not provide protection from flying objects including golf balls.
	This cab enclosure does not provide protection from lightning. When lightning threatens take cover and do not operate vehicle.

California Health and Safety Proposition 65 Warning: This product may contain chemicals known to the state of California to cause cancer and birth defects or other reproductive harm.

GENERAL INFORMATION BEFORE YOU START

HELPFUL HINTS:

- Refer to parts diagram found in the service parts section of this manual to help identify parts during the assembly process.
- To assist with the cab installation, leave all fasteners loose for later adjustment unless otherwise specified.
- Read and understand all instructions before beginning.
- Apply a silicone sealant to seal any minor gaps that may occur due to vehicle variations.
- Use caution to avoid damaging the factory installed threaded inserts or weld nuts. Begin the thread engagement by hand to avoid or correct potential cross threading.
- Make sure the areas where the supplied self-adhesive hook Velcro and seals will be applied are clean, dry, and at room temperature for best adhesion.
- Before installing parts with factory installed rubber, make sure the rubber is fully installed onto the parts for proper fit and sealing.

TOOLS REQUIRED:

- | | |
|--|--|
| <ul style="list-style-type: none"> • Set of Standard and Metric Sockets (3/8" Drive) • 3/8" Drive Ratchet with Extension • Torque Wrench • Set of Standard and Metric Open-End Wrenches • Set of Standard and Metric Allen Wrenches • #2 and #3 Phillips Head Screwdrivers • Flat Head Screw Driver • Body Clip Removal Tool • Pliers • Non-Marring Pick • (2) Quick Grip Clamps • Bar clamp (optional) • 5/16" Nut Driver • Coolant Drain Pan | <ul style="list-style-type: none"> • Drill/Driver • #2 and #3 Phillips Head Bit • Utility Knife • Pair of Scissors • Shears • Grease • Silicone Sealant • Teflon Tape • Tape Measure • China Marker or other Non-Permanent Marker • Snips |
|--|--|

CAB INSTALLATION

STEP 1: (VEHICLE PREP)

- 1.1 If tractor is equipped with a 100LC Loader, rotate loader valve hose loop up per figures 1.1a and 1.1b.

Tools required

22mm Wrench or Socket

- 1.2 Remove and position the loader (if installed) away from the vehicle.
- 1.3 Remove and set aside the ROPS mounted tool box and bracket along with its fasteners, if equipped. See fig. 1.3

Tools required

12mm Wrench or Socket

- 1.4 Remove and set aside the SMV sign and its bracket. See Figures 1.4.

Tools required

13mm Wrench and Socket

- 1.5 Remove outside ROPS hardware found on both sides of the tractor and set aside. See figure 1.5.

Tools required

19mm Wrench or Socket

- 1.6 Remove tail lights from factory mounts per figure 1.6. Note: you do not need to disconnect the lights.

Tools required

17mm Wrench or Socket

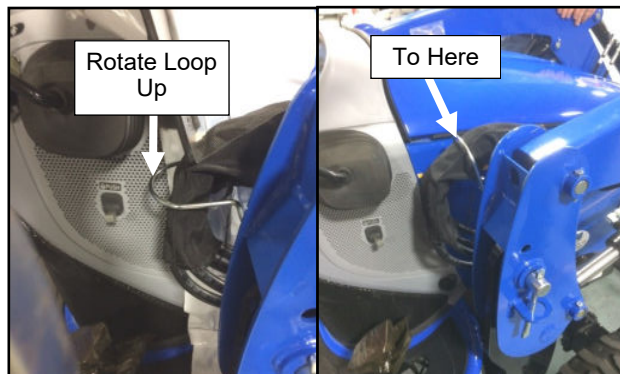

Fig. 1.1a & 1.1b (Rotate Hose Loop)



Fig. 1.3 (Remove ROPS mounted Tool Box)

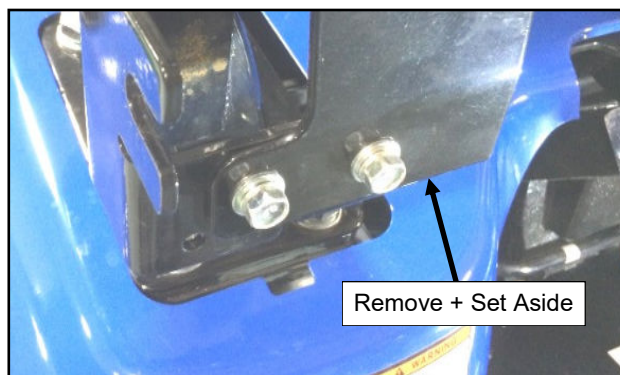

Fig. 1.4 (Remove SMV Sign Bracket)

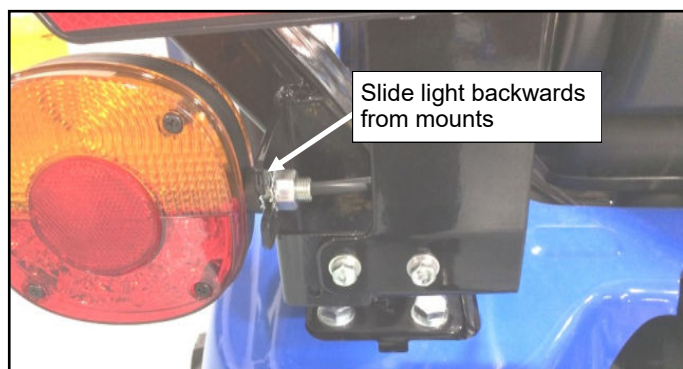

Fig. 1.6 (Tail Lights)

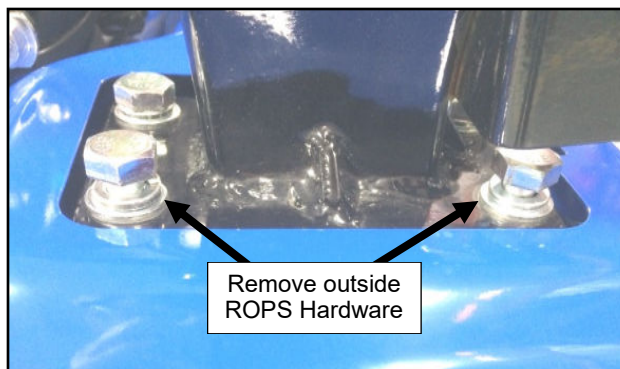

Fig. 1.5 (Outboard ROPS Fasteners)

CAB INSTALLATION

STEP 1: (VEHICLE PREP CONTINUED)

- 1.7 Pop the hood, disconnect the headlights per figure 1.7.
- 1.8 If Grill Guard is installed, remove and set aside with mounting hardware per figure 1.8.

Tools required

19mm Wrench or Socket

- 1.9 Remove grill and side panels (all one piece) from tractor.

Tools required

12mm Wrench or Socket

- 1.10 Following the manufacturer's instructions, remove the access panel under the dash and disconnect the battery.
- 1.11 Locate the fuse harness (WH-GF) in the hardware box. Make certain the fuse is installed in the fuse holder. Install the ring terminal of the fuse harness to the alternator. See Figure 1.11.
- 1.12 Reconnect battery and reinstall the access panel.
- 1.13 Install loader lock lever extension bracket onto factory lever. See Figure 1.13.

Hardware Used

#10-32 X 1/2" Flange Hex Head Screw

Qty

1

Tools required

5/16" Wrenches

Note: If installing optional seal kit (9SK8), or Adaptor Kit to Mount Cab without Loader (1NHWM25SAK), install now.

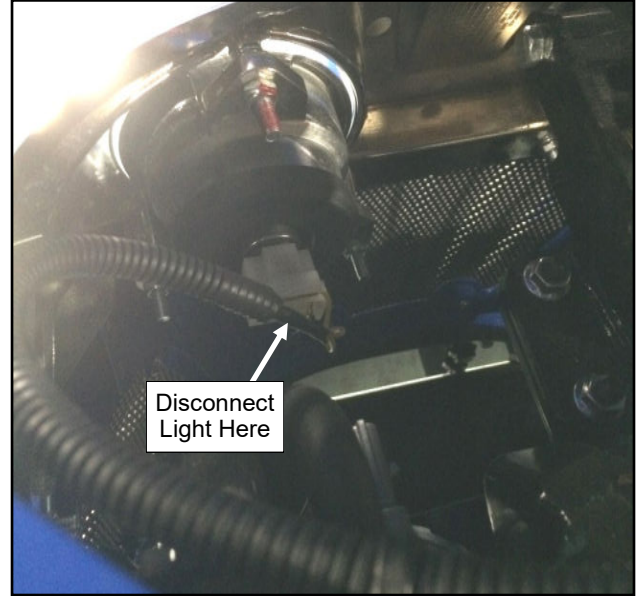

Fig. 1.7 (Disconnect Head Light, Left Side Shown)



Fig. 1.8 (Remove Grill Guard)

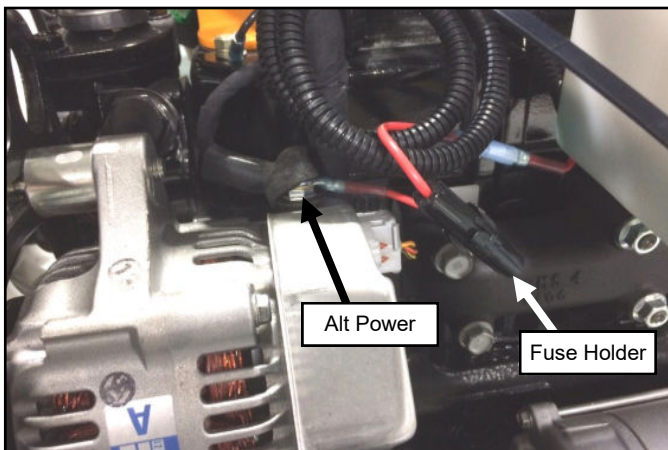

Fig. 1.11 (Fuse Harness Instalation)

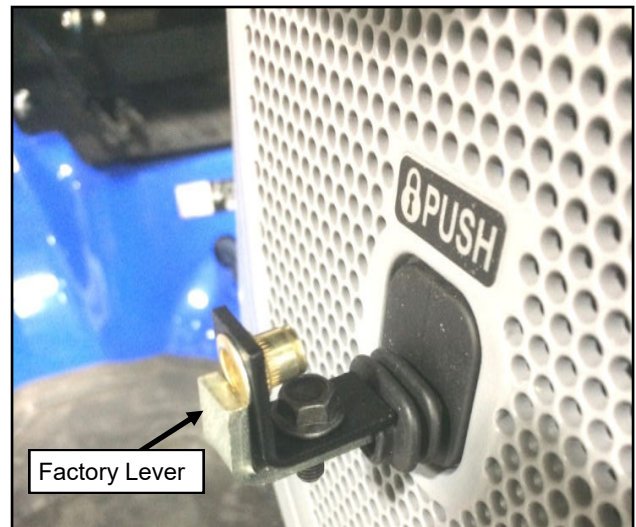

Fig. 1.13 (Install Lock Lever Ext Bracket)

CAB INSTALLATION

STEP 2: (REAR MOUNT BRACKETS)

- 2.1 Using the fasteners listed below and those that were removed during step 1.4, first install the spacers and then the rear mount bracket on the left side of vehicle with the small flange facing up. See Figure 2.1.

<u>Hardware Used</u>	<u>Qty</u>
1/2" ID X 3/4" OD X 5/32" THK Spacer	2

Tools required
17mm Wrench or Socket

- 2.2 Install lower left mount per Figure 2.2.

<u>Hardware Used</u>	<u>Qty</u>
5/16-18 X 3/4 Hex Head Screw	2
5/16-18 Hex Nut	2

Tools required
1/2" Wrench and Socket

- 2.3 Install left tail light on rear mount bracket, removed during step 1.5. See Figure 2.3.

Tools required
17mm Wrench

- 2.4 Repeat steps 2.1 thru 2.3 on the right side of the vehicle.

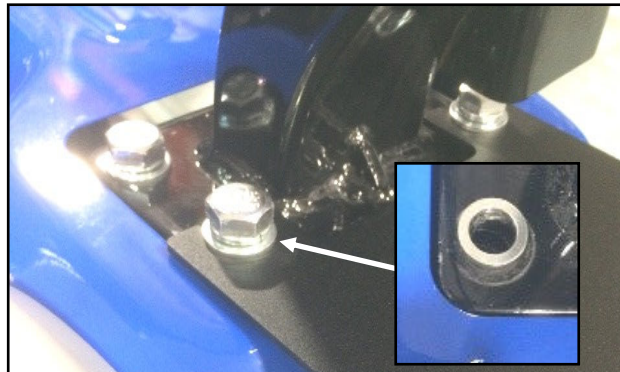

Fig. 2.1 (Rear Mount Bracket Orientation)



Fig. 2.2 (Lower Rear Mount Orientation)

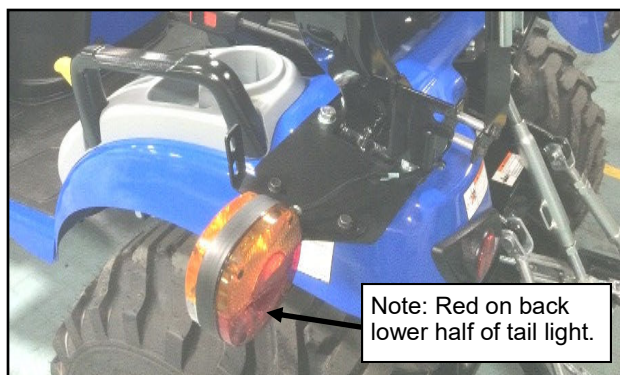

Fig. 2.3 (Re-Install Tail Light)

STEP 3: (ROPS BRACKETS AND CLAMPS)

- 3.1 Measure down from the tab found on the ROPS Structure approximately 7/8". Make a mark using a china marker or other non-permanent marker. Install the left ROPS bracket and clamp. See Figure 3.1.

<u>Hardware Used</u>	<u>Qty</u>
5/16-18 X 3/4 Hex Head Screw	4
5/16-18 Hex Nut	4

Tools required
1/2" Wrench and Socket

- 3.2 Repeat step 3.1 on the right side of the vehicle.



Fig. 3.1 (ROPS Bracket and clamp, left)

CAB INSTALLATION

STEP 4: (RADIATOR SHROUD, LOAD LOCK LEVER & COWL)

- 4.1 Position the radiator shroud on the vehicle just in front of the front lip of the floorboard per figure 4.1. *Install Tip: If needed, move the rubber boot of the jockstick out of the way when placing the shroud in place. Place the boot back in place once shroud is placed.*
- 4.2 Install Thumb Screw into previously installed Load Lock Lever Extension bracket (Step 1.10). Make sure there is enough thread on the inside for a hex nut to fit. Then thread and tighten on the hex nut on the inside. See Figures 4.2a and 4.2b.

<u>Hardware Used</u>	<u>Qty</u>
Thumb Screw, 3 inches long	1
#10-32 Hex Nut	1

Tools required
3/8" Wrench or Socket

- 4.3 Install steel cowl in front of radiator shroud per figure 4.3a. For best seal, make sure that rubber running across the top of the dashboard (between the white arrows) is pushed back and pushed forward as it runs down the side of the dash (outside the white arrows) as shown in figure 4.3b.

<u>Hardware Used</u>	<u>Qty</u>
1/4-20 Thumb Nut	5

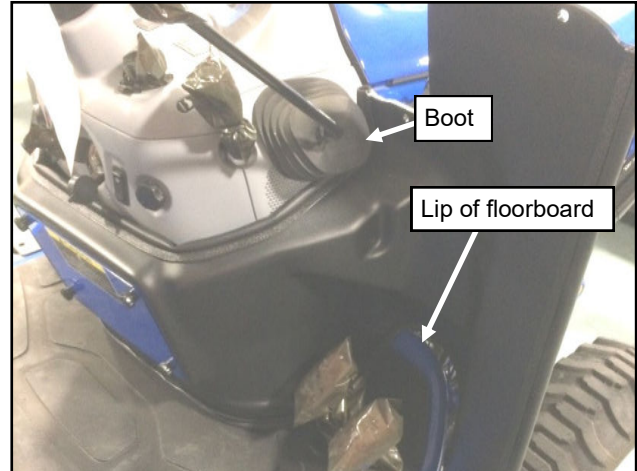

Fig. 4.1 (Radiator Shroud, Right)



Figure 4.2a (Load Lock Lever, Cab inside)

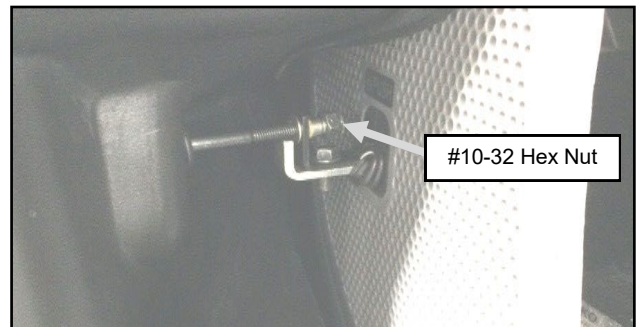

Figure 4.2b (Load Lock Lever, Cab outside)

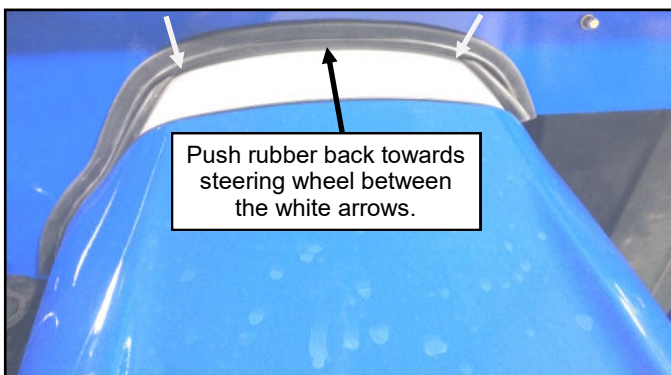

Fig. 4.3b (Cowl Rubber)



Fig. 4.3a (Cowl)

CAB INSTALLATION

STEP 5: (REAR LEGS)

- 5.1 Fasten the rear leg to the previously installed ROPS brackets. See Figure 5.1.

Hardware Used	Qty
5/16-18 X 3/4 Hex Head Screw	2
5/16-18 Hex Lock Nut	2

Tools required
1/2" Wrench and Socket

- 5.2 Repeat step 5.1 on the right side of vehicle.

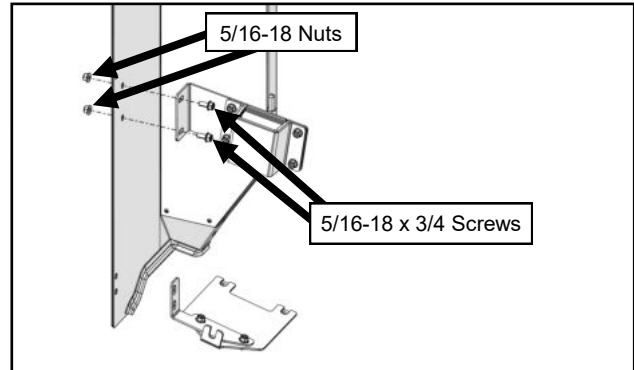

Fig. 5.1 (Rear Leg to Side Frame Fasteners)

STEP 6: (LOWER FRONT MOUNTS)

- 6.1 Install left side lower front mount using supplied hardware listed below. See Figure 6.1. **Note: If backhoe or No-Loader Adapter Kit is installed, 1/2" spacers are not required.**

Hardware Used	Qty
M12x1.75 X 55 Hex Head Screw	2
M12 Washer	2
M12x1.75 Flange Hex Nut	2
1/2" ID X 3/4" OD X 1/2" THK Spacer	2

Tools required
19mm Wrench and Socket

- 6.2 Repeat step 6.1 on the right side of vehicle.

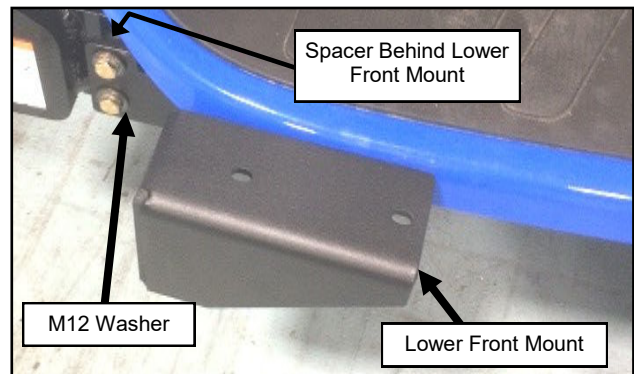

Fig. 6.1 (Lower Front Mount, Left)

STEP 7: (SIDE FRAMES)

- 7.1 With assistance, remove the pre-assembled left door from the left side frame and set aside. Do not lose the brass washers on the hinge pins.
- 7.2 Fasten the left side frame to the left Front Mount, Radiator Shroud, and Rear Leg. See Figures 7.2a and 7.2b.

Hardware Used	Qty
5/16-18 X 3/4 Hex Head Screw	5
5/16-18 X 1 Button Head Screw	2
5/16-18 Flat Washer	2
5/16-18 Hex Nut	2
1/4-20 Thumb Nut	1

Tools Required
1/2" Wrench or Socket
3/16" Allen Wrench

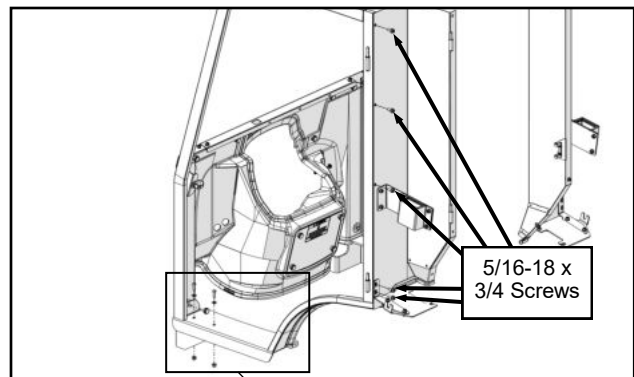

Fig. 7.2a (Side Frame)

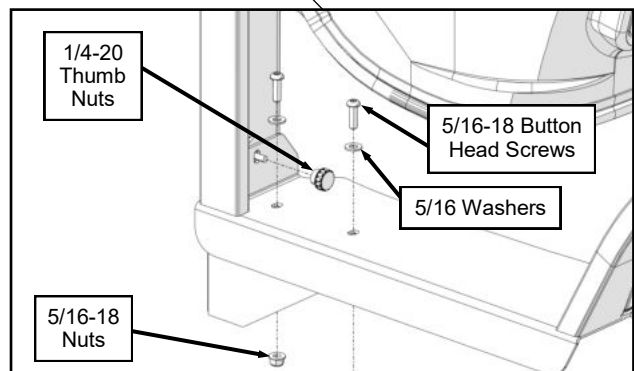

Fig. 7.2b (Side Frame, Detail View)

CAB INSTALLATION

STEP 7: (SIDE FRAMES CONT'D)

7.3 Fasten the side frame to the cowl as shown in Figure 7.3.

<u>Hardware Used</u>	<u>Qty</u>
5/16-18 X 3/4 Hex Head Screw	2
5/16-18 Hex Nut	2

Tools required
1/2" Wrench and Socket

7.4 Repeat steps 7.1 thru 7.3 on the right side of the vehicle.

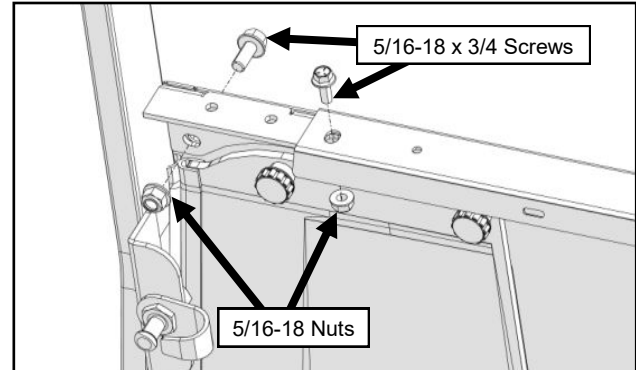

Fig. 7.3 (Side Frame to Cowl Fasteners)

STEP 8: (WINDSHIELD SUPPORT)

8.1 With assistance, align sides and top of the windshield support with the side frames. Fasten the windshield support in place with a screw through the front of each side frame. See Figure 8.1. Confirm bolt holes in the top of the windshield support align with the inserts in the side frames and tighten hardware.

<u>Hardware Used</u>	<u>Qty</u>
5/16-18 X 3/4 Hex Head Screw	2

Tools required
1/2" Wrench or Socket

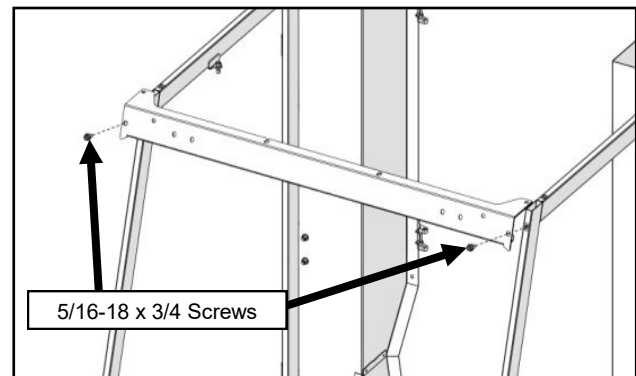

Fig. 8.1 (Windshield Support to Side Frame Fasteners)

STEP 9: (LOWER REAR PANEL)

9.1 Fasten the lower rear panel to the rear legs as shown in Figure 9.1.

<u>Hardware Used</u>	<u>Qty</u>
1/4-20 X 5/8 Hex Head Screw	4
1/4-20 Flange Hex Nut	4

Tools required
3/8" Wrench and Socket
7/16" Wrench and Socket

Note: On backhoe equipped vehicles, the lower rear panel will need to be removed to operate the backhoe. It is up to the discretion of the operator whether or not to reinstall.

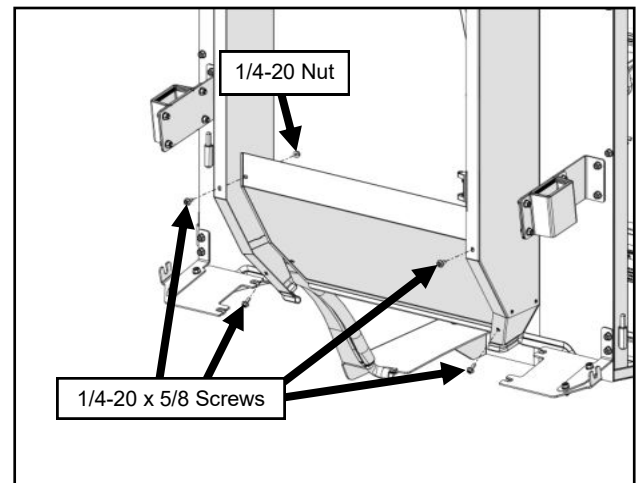

Fig. 9.1 (Lower Rear Panel)

CAB INSTALLATION

STEP 10: (CAB WIRING)

10.1 Attach the main power wire harness to the top of the cowl, about 6" from the end of the windshield wiper motor connector, using supplied zip-ties. The connector end should be outside the cab with the rest of the harness on the inside. See Figure 10.1.

Hardware Used	Qty
11" Long Zip-Tie	3

10.2 Snap the heater switch into the rectangular cutout in the top of the cowl and connect the wire harness.

10.3 Run the wire harness over to and down the left side frame through the gap between the floorboard and intake shroud. Secure it in (2) places along the side frame using P-clamps and self-drilling screws. See Figure 10.3.

Hardware Used	Qty
#10 x 3/4" Pan Head Self-Drill Screw	2
P-Clamps	2

Tools required
 #2 Phillips Bit
 Drill/driver

10.4 Run the harness to the alternator as shown in Figures 10.4 and 10.5 making sure that wires will not be cut or pinched passing by the radiator or moving parts.

10.5 Locate the fuse harness (WH-GF) and connect the fuse harness to the main power harness via the bullet connectors. See Figure 10.5.

10.6 Install the ring terminal of the main power wire harness to the vehicle's engine. Coil the slack in the power harness and secure with a wire tie. See Figure 10.5. Double check that the wires are not pinched or near sharp or hot surfaces.

NOTE: At the installer's discretion, wiring for accessories may also be installed into the engine compartment at this time.

10.7 Secure wires (with wire ties provided) away from any hot or moving engine components where it could melt or be pinched.

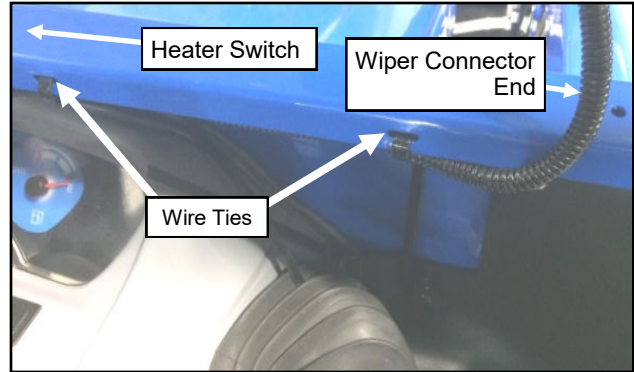

Fig. 10.1 (Attach Main Harness To Cowl)

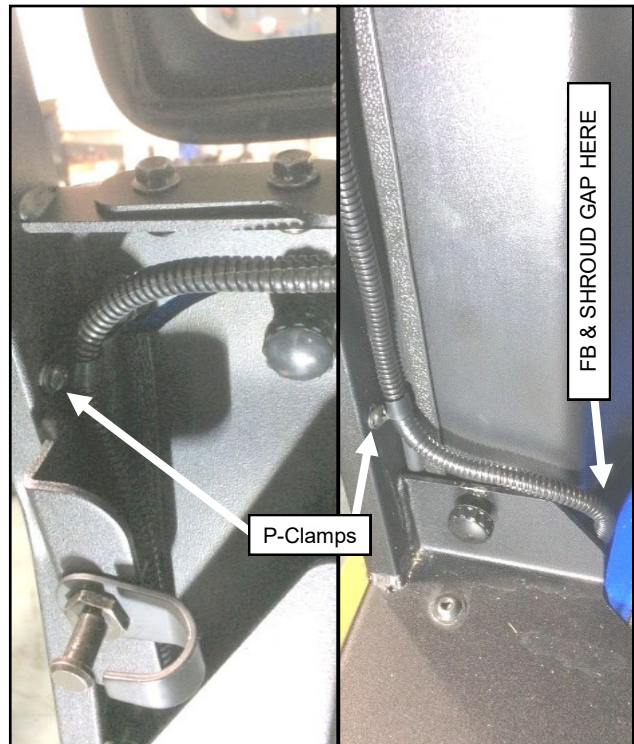

Fig. 10.3 (Secure Harness to Side Frame)

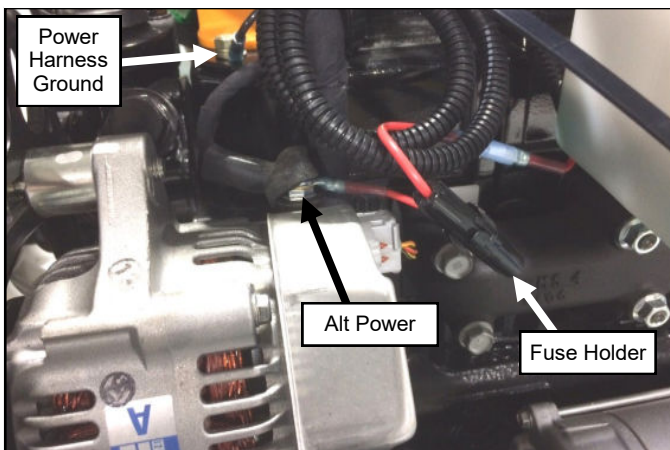

Fig. 10.5 (Power Harness Connections)

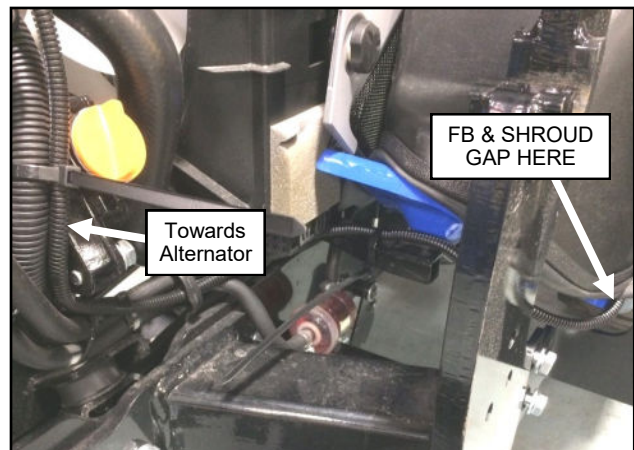

Fig. 10.4 (Power Harness to Hood)

CAB INSTALLATION

STEP 11: (WINDSHIELD)

11.1 With assistance, set the windshield up to the side frames and secure it to the windshield support using the hinge spacers and hardware. See Figure 11.1. Leave hardware loose.

Hardware Used	Qty
5/16-18 x 1.5" Flat Head Screw	4
5/16-18 Hex Lock Nut	4

Tools required
#3 Phillips screw driver
1/2" Wrench or Socket.

11.2 Secure the windshield latches to the side frames with the latches open, and tighten latch hardware. See Figure 11.2.

Hardware Used	Qty
1/4-20 x 5/8" Hex Head Screw	4
1/4-20 Hex Lock Nut	4

Tools required
3/8" Wrench or Socket
7/16" Wrench or Socket

11.3 Close the windshield while lifting up on the bottom edge. Tighten hinge hardware.

Caution: The windshield hinges are plastic components. Do not overtighten the flat head screws. Torque to 7 ft.-lbs. max.

11.4 Ensure the windshield latches function properly and the windshield pivots open.

11.5 Remove the over tightening caution decal from the top of the windshield.

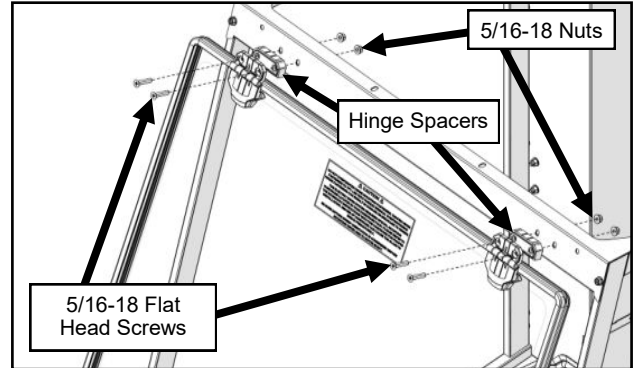

Fig. 11.1 (Windshield)

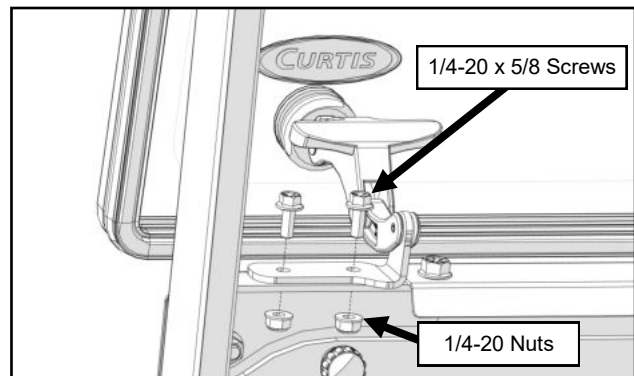

Fig. 11.2 (Secure Windshield Latches)

STEP 12: (WINDSHIELD WIPER MOTOR)

12.1 Mount the wiper motor to the windshield. See Figure 12.1. Make sure the wires are above the wiper motor shaft to prevent pinching the wires when the windshield is opened and closed, then connect to the wire harness.

NOTE: The wiper arm and blade will be installed in a later step. The wiper motor should easily clear the cowl, but if not, loosen the windshield hinges and raise the windshield to gain some clearance.

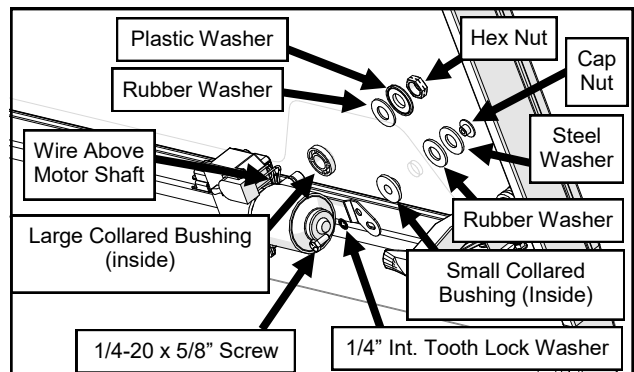

Fig. 12.1 (Windshield Wiper Motor)

CAB INSTALLATION

STEP 13: (ROOF)

13.1 Per figure 13.1, pierce the headliner in (6) places where the rubber plugs were previously removed. Use a screwdriver to poke holes through the headliner from the headliner side up through the hole in the roof to avoid having the headliner pull away from its glued surface.

13.2 With assistance, set the roof on top of the cab. Loosely secure with (6) screws and plastic seal washers on the top of the roof into the windshield support and side frames. With an additional (2) screws and nuts on back edge of the roof into the rear legs. See Figures 13.2a and 13.2b.

Hardware Used

	Qty
5/16-18 x 3/4" Hex Head Screw	8
5/16" Plastic Seal Washer	6
5/16-18 Flange Hex Nut	4

Tools required

1/2" Wrenches and/or Sockets

13.3 Once all roof fasteners are started, measure the width of the rear legs (outside to outside). Adjust the width if needed to 27-7/8". Measure opening corner to corner for squareness and clamp the rear flange of the roof to each of the rear legs. If necessary a bar clamp may be used to pull the rear legs in to 27-7/8". See Figures 13.2b and 13.3.

Note: Leave the clamps in place until all cab fasteners are tightened during the following steps.

Tools required

(2) Quick Grip Clamps
Tape Measure

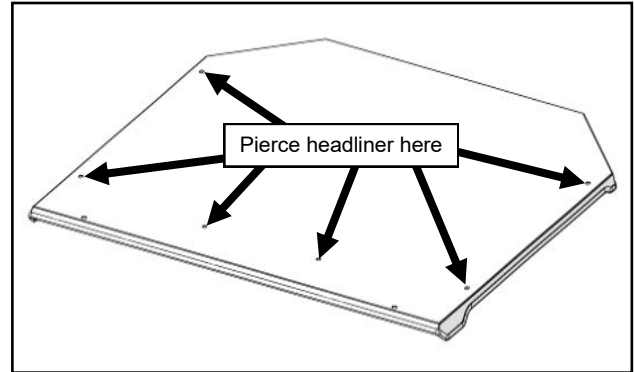

Fig. 13.1 (Roof Preparation)

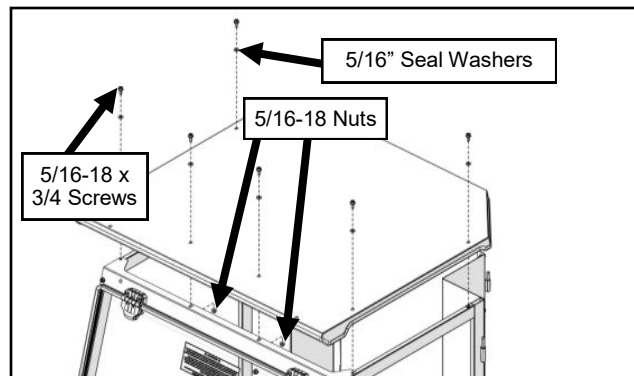

Fig. 13.2a (Roof Fasteners)

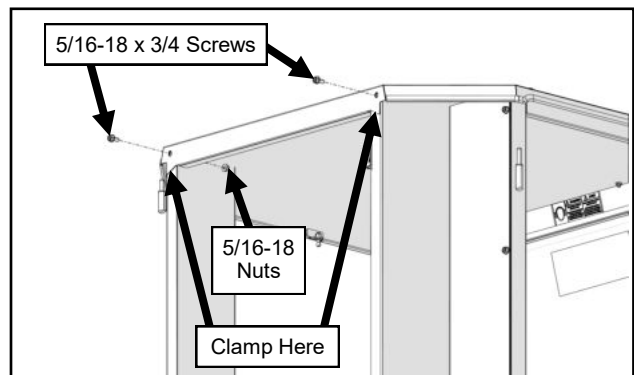

Fig. 13.2b (Roof Fasteners)

STEP 14: (TIGHTEN HARDWARE)

14.1 Tighten all hardware at this time, using the torque values found on the last (2) pages of this manual.

Note: Each side frame can be pushed inward at the back to close any gaps along the fender contour before tightening hardware.

Note: Suggested tightening sequence is as follows:
Floorboards, cowl, rear mounts, rear legs, lower rear panel, roof, and ROPS brackets.

14.2 Once all hardware is fully tightened, remove the (2) quick grip clamps from the roof/rear legs.

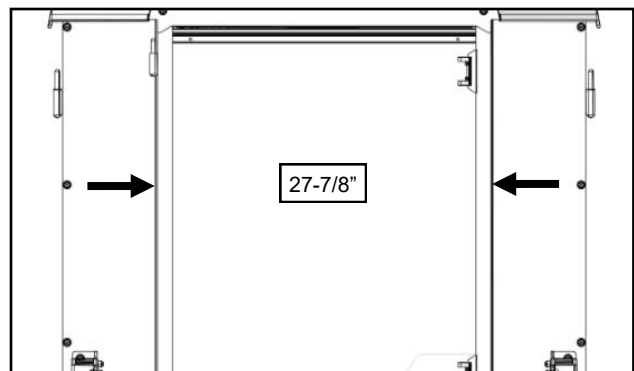

Fig. 13.3 (Squaring of Rear Legs and Roof)

CAB INSTALLATION

STEP 15: (REAR WINDOW)

- 15.1** Grease the hinge pins found on the left side rear leg and slide on greased brass washers (one washer per pin). See Figure 15.1.
- 15.2** Hang the rear window on the hinges.
- Note: Loosen rear window hinges if adjustment is needed.
- 15.3** Connect the window latches to the right rear leg by depressing the tabs on the latch and inserting into the receivers mounted on the rear leg. Close and check the alignment of the window. If off, check measurements and re-align the rear legs. Tighten the hinge hardware to 7 ft.-lbs. Verify smooth operation of the latches.

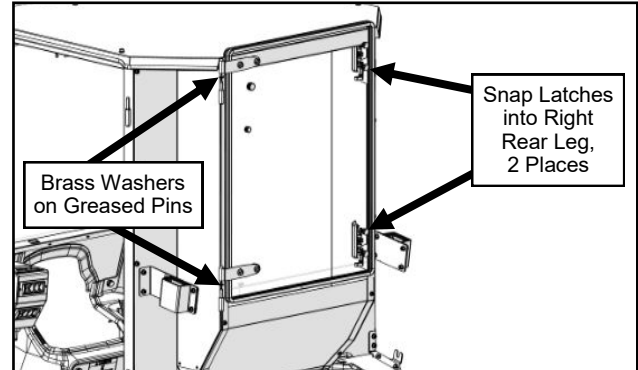

Fig. 15.1 (Hang Rear Window)

STEP 16: (HEATER)

- 16.1** Attach the heater bracket to the left side frame. See Figure 16.1. Fully tighten hardware at this time.

<u>Hardware Used</u>	<u>Qty</u>
5/16-18 x 3/4" Hex Head Screw	2

Tools required
1/2" Socket with Extension

- 16.2** Attach the heater to the heater bracket by removing and re-using the screws on the side of the heater. Tighten hardware.

Tools needed
#2 Phillips Screw driver.

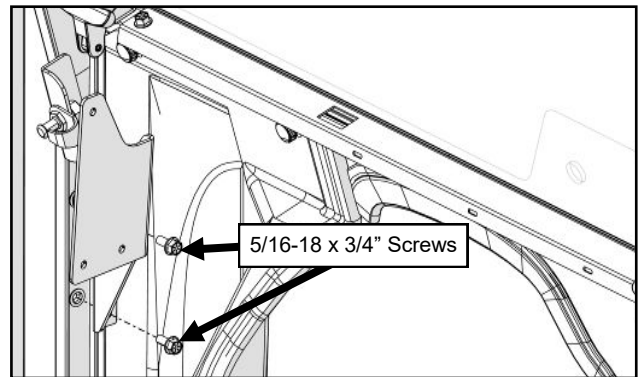

Fig. 16.1 (Install Heater Bracket to Side Frame)

STEP 17: (HEATER PLUMBING)

- * **CAUTION** * To avoid injury caused by hot engine coolant, make sure the engine has completely cooled down before beginning plumbing of auxiliary heater.

- 17.1** Place a clean coolant drain pan under the radiator. Next, drain coolant from radiator petcock. See fig. 17.1.
- 17.2** Snap provided 3/4" bushings into the plastic radiator shroud from the inside. Cut (2) 17" pieces of the provided 5/8" diameter heater hose. Slide (2) 1" hose clamps on the end of the (2) cut hoses. Slide the hoses onto the end of the (2) heater nipples and tighten down the hose clamps. Next, slide the (2) hoses through the snap bushings. Make sure not to kink the hose. See Figure 17.2.

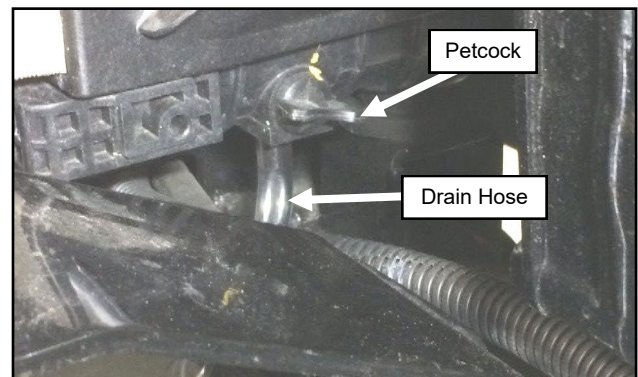

Fig. 17.1 (Petcock Valve Under Radiator, Right Side)

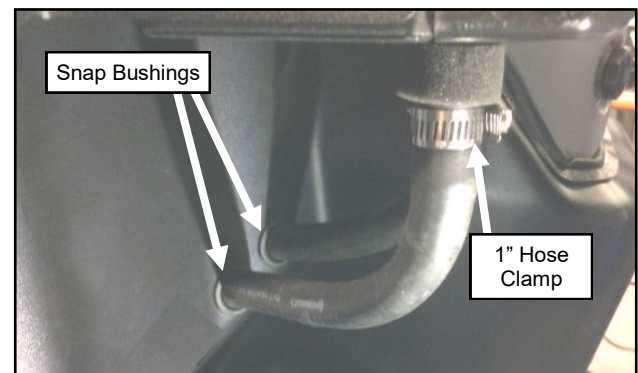

Fig. 17.2 (Heater Hose Routing)

CAB INSTALLATION

STEP 17: (HEATER PLUMBING CONTINUED)

- 17.3** Slide 1" hose clamp and Female Insert In-Line Coupling onto the right hose outside the cab and tighten down hose clamp onto hose/barb of in-line coupling. See figure 17.3
- 17.4** Slide 1" hose clamp and Male Insert In-Line Coupling onto the left hose outside the cab and tighten down hose clamp onto hose/barb of in-line coupling. See figure 17.3
- 17.5** Connect the mating in-line couplings to the previously installed couplings. Cut 51 inches of heater hose, install hose and 1" hose clamp onto the right side hose coupling and run hose towards the front of the vehicle using figures 17.3 and 17.6 as reference. With remaining heater hose, install hose and 1" hose clamp onto the left side hose coupling. Again using figures 17.3 and 17.6 for suggested routing.
- 17.6** Run heater hose per figure 17.6.
- 17.7** Disconnect temp sensor wire from the back of the temperature sensor. Remove 3/8" plug as well as temperature sensor and brass washer from water pump. See figure 17.7.
- 17.8** Install block adapter into 3/8" plug location per figure 17.7.
- 17.9** Using the (3) supplied nylon washers as needed to seal the sending unit and have the threaded section point up as shown on figure 17.9.
- 17.10** Re-install brass washer and temperature sensor into the backside of the sending unit adapter per figure 17.9.

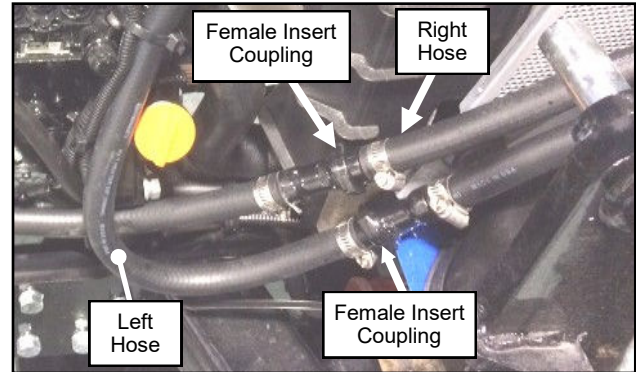

Fig. 17.3 (Heater Hose Disconnects, Outside of Cab)

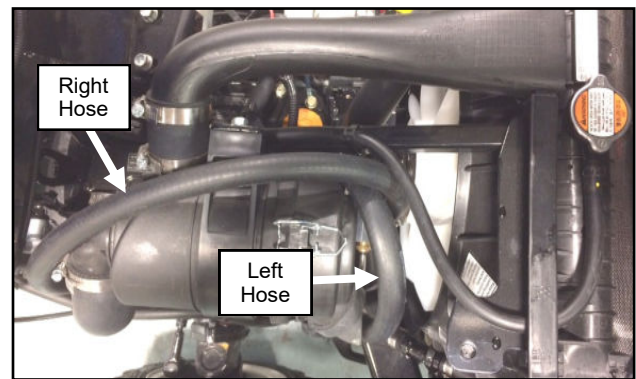

Figure 17.6 (Heater Hose Routing)

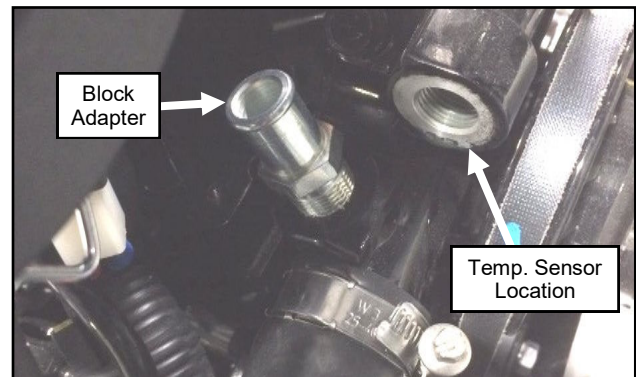

Figure 17.7 (Block Adapter Install)

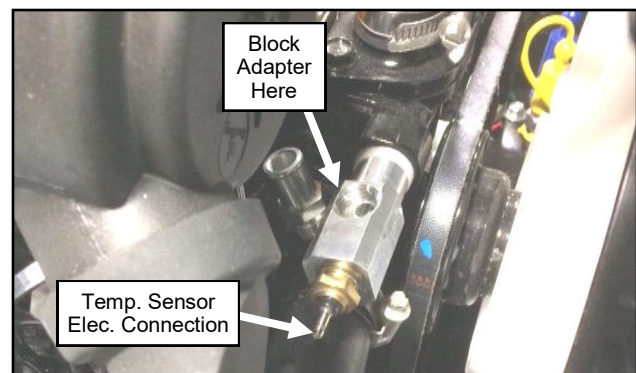

Figure 17.9 (Sending Unit Install)

CAB INSTALLATION

STEP 17: (HEATER PLUMBING CONTINUED)

17.11 Install block adapter onto the top of the sending unit adaptor. Next, install right side 5/8" heater hose and 1" hose clamp onto the recently installed block adapter. Re-connect temp. sensor wire to temp. sensor. See figure 17.11.

17.12 Install left 5/8" heater hose (cut as needed) and 1" hose clamp onto the other block adapter. See figure 17.11.

17.13 Secure all heater hoses from moving parts and excessive heat sources with the supplied wire ties.

Note: Turn the wheels all the way to the right and left to ensure adequate clearance between the tires and hoses. Also, make sure that heater hose routing will not interfere with loader reinstallation.

17.14 Re-install grill and side panels, removed on step 1.9. Reconnect head light disconnected on step 1.7.

Tools required

12mm Wrench or Socket

STEP 18: (FINISH HEATER)

18.1 Connect the leads found on the heater to the main power wire harness (orange to orange, red to red & black to black). See Figure 18.1.

18.2 Install the provided 13" length of 1/2" wire loom to the heater leads.

18.3 Refill the cooling system. Start the tractor and inspect coolant system for leaks.

18.4 With the tractor running, check the heater hoses and make sure they get warm. If not, remove the heater from its mount and let hang from the hoses as low as possible. If the heater and hoses still do not get warm, temporarily put a clamp on the upper radiator hose to force coolant through the heater. **Warning:** To avoid engine damage, remove the clamp as soon as heater gets warm. Reattach heater to the bracket. Once complete, let the engine cool, check the coolant level, and top off coolant if required.

STEP 19: (FINISH WIPER)

19.1 Turn on the wiper motor briefly, then turn back off. This will ensure the motor shaft is in the correct parked position.

19.2 Pre-assemble the wiper arm and wiper blade.

19.3 Install the wiper arm onto the wiper motor so that the wiper is horizontal. See Figure 19.3. Tighten the Set Screws.

Tools required

2.5mm Allen Wrench

19.4 Adjust the length of the wiper arm as long as possible while still clearing the outer cap nut for the windshield latches. Turn on the wiper to check proper operation. Reference step 5 of the wiper installation instructions.

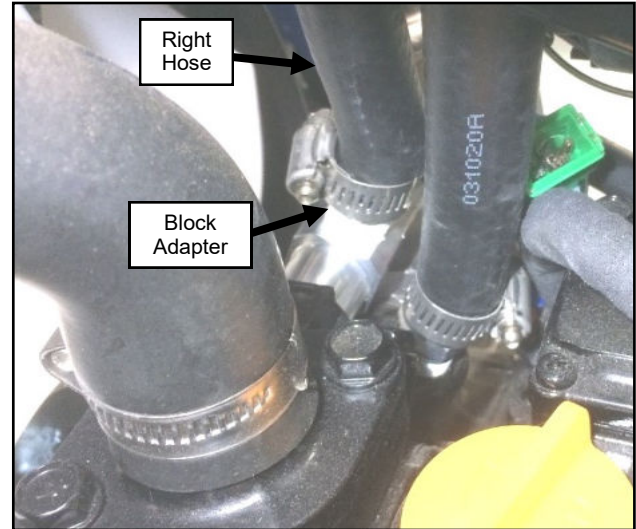

Figure 17.11 (Heater Hose Install)

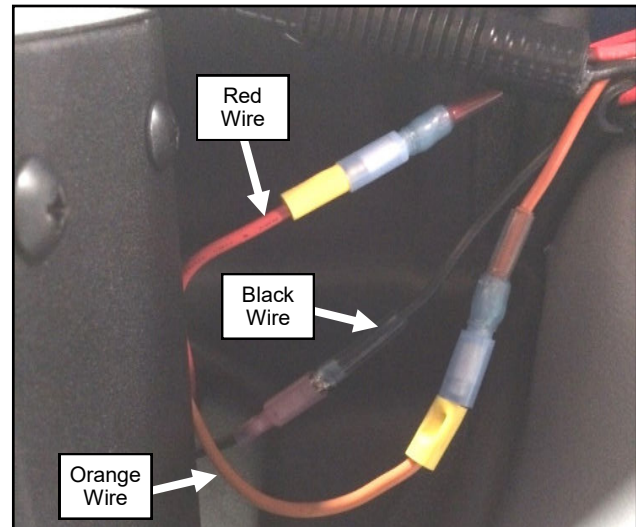

Fig. 18.1 (Heater Power Connections)

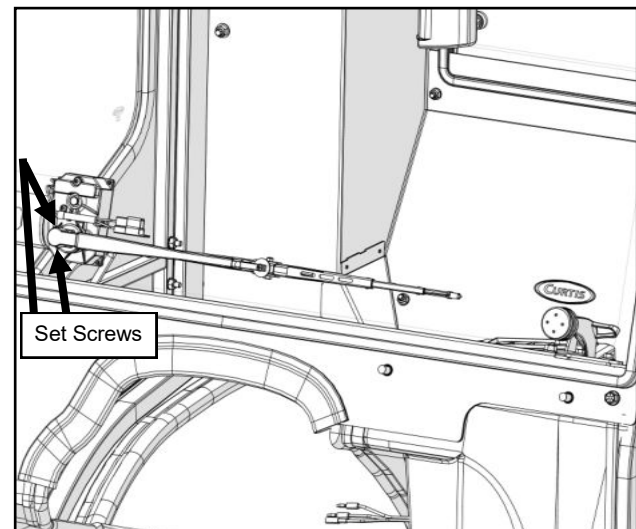

Fig. 19.3 (Wiper Arm and Blade)

CAB INSTALLATION

STEP 20: (SMV SIGN)

- 20.1 Re-install SMV Sign and Bracket removed on step 1.3 using the supplied 40mm long spacers (ref.: 1.57" long) per figure 20.1.

<u>Hardware Used</u>	<u>Qty</u>
M8X1.25 X 60mm Hex Screw	2
M8 X 40mm long spacer	2

Tools required
13mm Wrench and Socket

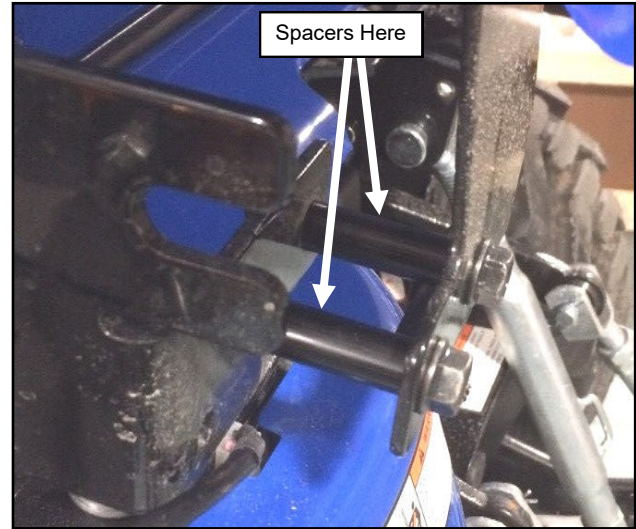

Fig. 20.1 (Relocated SMV Sign and Bracket)

STEP 21: (Tool Box Relocation)

- 21.1 Remove factory tool box from factory mounting bracket.

Tools required
13mm Wrench or Socket

- 21.2 Secure the supplied tool box relocation bracket to the ROPS with the hardware that was removed during step 1.2. See Figure 21.2. *Note: can be installed on the left or right side of ROPS depending on desired access on backhoe (if installed).*

Tools required
12mm Wrench or Socket

- 21.3 Fasten the factory tool box to the previously installed relocation bracket as shown in Figure 21.3.

<u>Hardware Used</u>	<u>Qty</u>
5/16-18 x 3/4" Hex Head Screw	2
5/16-18 Hex Nut	2

Tools required
1/2" Wrench and Socket



Fig. 21.2 (Tool Box Offset Bracket, Left side of ROPS)



Fig. 21.3 (Install Tool Box onto Offset Bracket)

CAB INSTALLATION

STEP 22: (DOORS)

22.1 Check to make sure that the brass washers are still installed on the left side hinge pins and then apply grease to the pins.

22.2 Hang the left door on the hinge pins.

Note: If necessary, adjust the door as outlined in steps 22.3 thru 22.5.

22.3 Loosen the door hinges to allow for adjustment later. While lifting up and forward on the door handle, line up the door latch with the striker pin and carefully attempt to latch. You should be able to hear 2 clicks as you slowly engage the latch on the pin. If the latch is too far forward or back to latch on the pin, adjust as shown. See Figures 22.3a through 22.3c. Then retighten and latch.

22.4 Stand back and examine the alignment of the door with the roof and the A-pillar. You can adjust this by moving the striker pin up or down as shown to help with alignment. *TIP: In the final step, the front of the door will drop a small amount the first time you open it. Set the front of the door a little bit higher so it aligns properly.* Adjust as necessary until you are happy with the alignment. Have an assistant sit inside the cab and once more carefully close the door like you did in step 22.3. Work with the assistant and tighten the hinge bolts.

22.5 Open the door and check for smooth operation of the latch. As noted in step 22.4, the door will likely drop a little bit at the front and the striker pin will need to be adjusted down accordingly. Also make sure the door seal is making contact along the perimeter of the door and the latch clicks twice when closing. If necessary, adjust the striker in or out to achieve this.

22.6 With the door open, attach a gas strut to the ball studs on the side frame and door. Make sure the quick release end is on the side frame so that the gas strut stays with the door if removed for ventilation.

22.7 Repeat steps 22.1 through 22.6 for the right door.

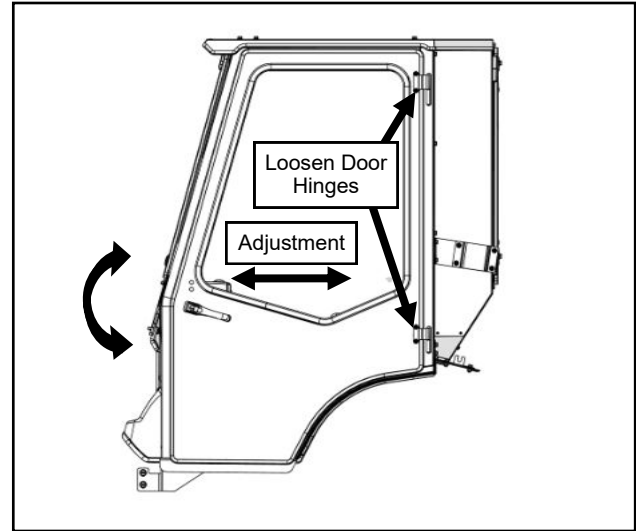

Fig. 22.3a (Door Hinge Adjustment)

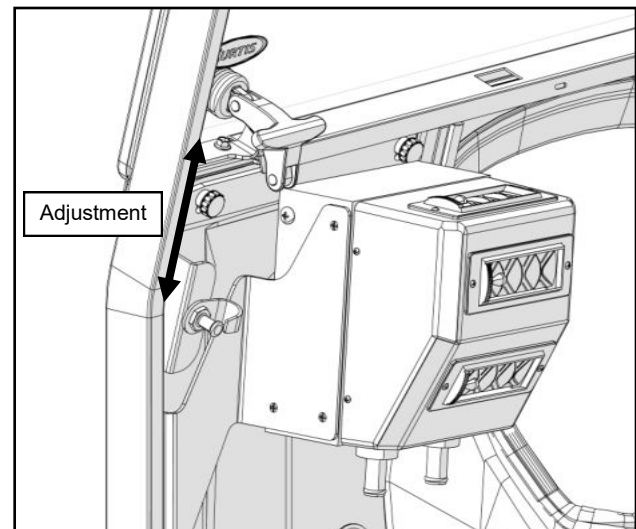

Fig. 22.3b (Striker Pin Adjustment)

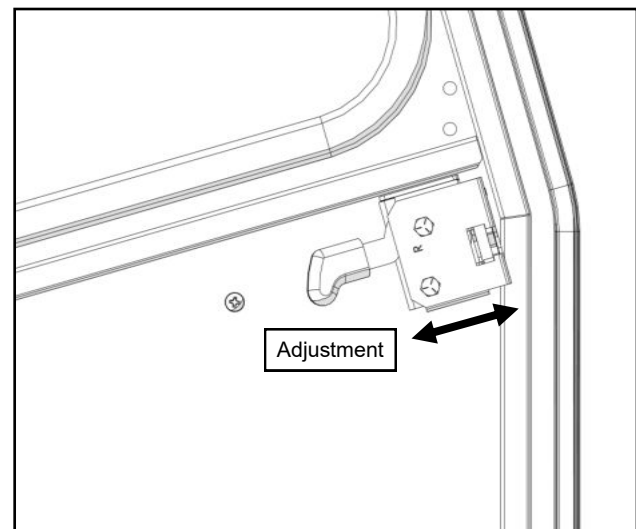

Fig. 22.3c (Door Latch Adjustment)

CAB INSTALLATION

STEP 23: (ACCESSORIES/PLUGS)

23.1 If installing accessories, please do so now. If not, use the supplied plugs to fill any exposed holes. See Figures 23.1a and 23.1b.

23.2 Per figure 23.2, install (7) insert covers.

23.3 Optional Rear Wiper Note:

For easier wiper motor harness disconnection, cut the main wiring harness connector off a few inches from the end and create a jumper harness with it using bullet connectors. **Do not cut the connector off the wiper motor.**

Strip all the wires, crimp a male bullet connector onto the ground (black) wire of the main wire harness and a female bullet connector on the positive (red) wire.

Reverse the male and female bullet connectors on the new jumper wire harness so that the male bullet connector is on the positive (red) wire and the female bullet connector is on the ground (black) wire.

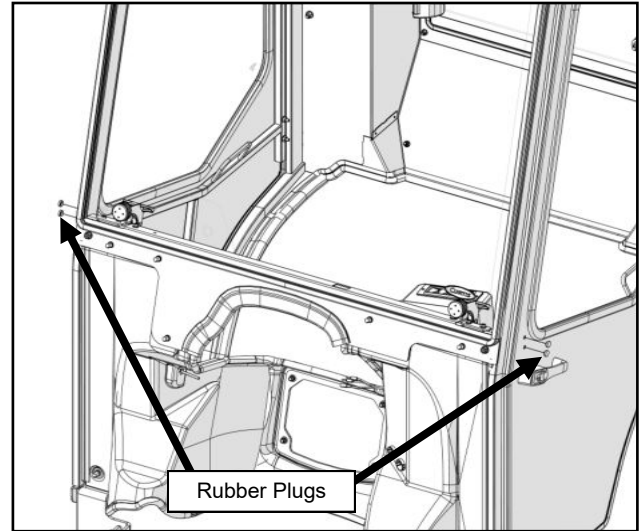

Fig. 23.1a (Install Plugs, Door)

STEP 24: (FINISHING TOUCHES)

24.1 Install caution sticker on right side of ROPS per figure 24.1.

24.2 Reinstall the grill guard and loader if equipped.

Tools required

19mm Wrench or Socket

24.3 Due to the nature of the packaging materials used for shipping this product, the components of the cab system may have dust on their surfaces upon removal from the packaging. It is recommended that after completion of the cab installation, the cab and vehicle are washed thoroughly to eliminate any dust or contaminants. See the Care and Maintenance section at the back of this manual for critical information on cleaning the cab.

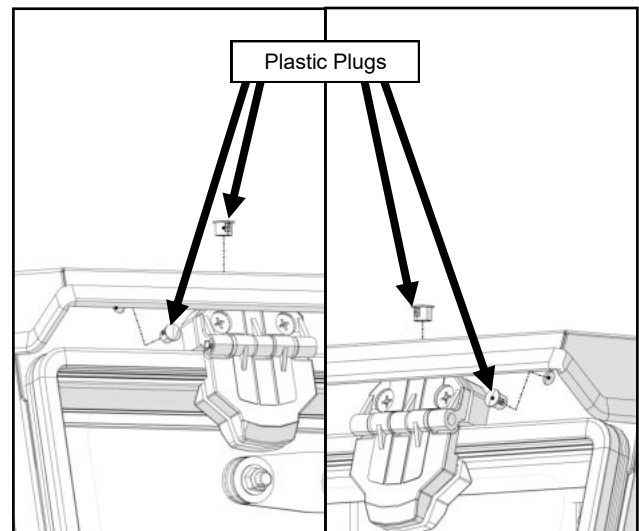

Fig. 23.1b (Install Plugs, Roof)



Fig. 24.1 (Install ROPS Caution Sticker)

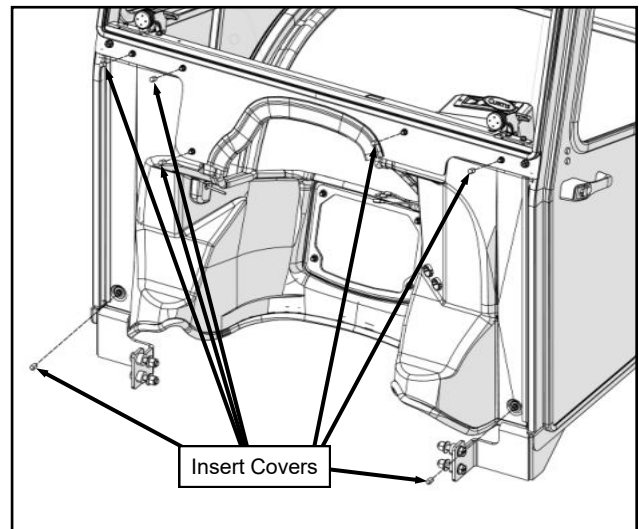
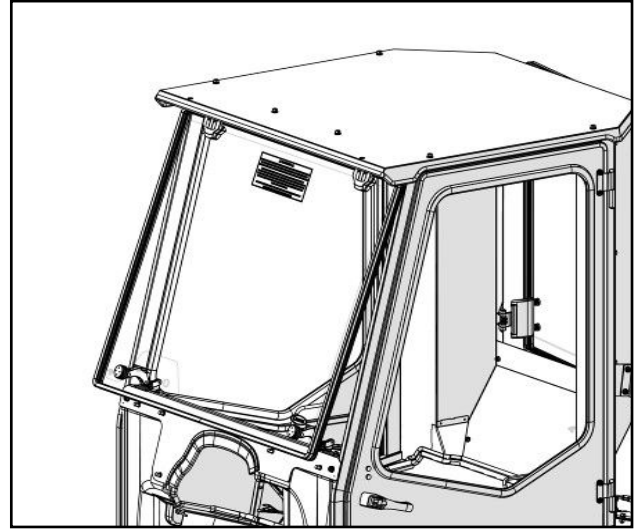

Fig. 23.2 (Install Insert Covers)

CAB FEATURES & OPERATION

POP-OUT WINDSHIELD

Your Workmaster 25S cab comes equipped with a pop-out windshield for ventilation. To open the windshield, simply lift up on both of the pop-out latches and rotate until the latches rest in the over-center position.



Pop-Out Windshield

LIFT-OFF DOORS

For added ventilation, the doors on the Workmaster 25S cab lift off in seconds without tools.

To lift off:

1. Disconnect the gas strut from the side frame by sliding the quick release lever and pulling the strut down.
2. Rotate the doors 90° to the cab and lift. Also, remove the hinge washers and store in a plastic bag.

Store the doors in a safe location to prevent damage.

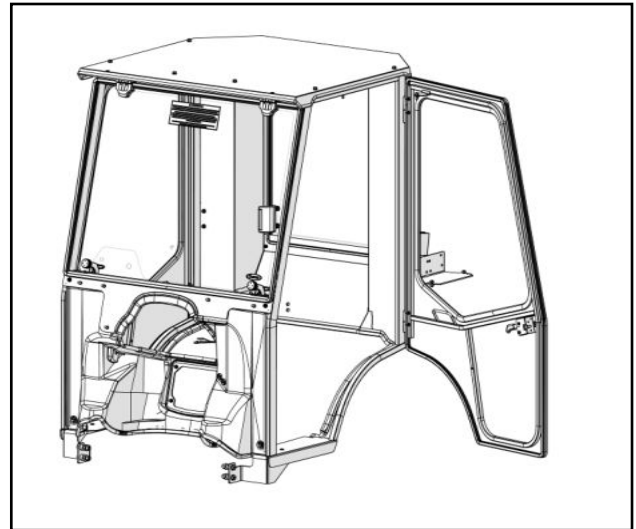

Lift-Off Doors

REMOVABLE REAR WINDOW

The rear window can also be removed for added ventilation.

To remove the rear window:

1. Open both window latches and disconnect from right rear leg with tabs on latch. Open the window taking care not to let the window open into the ROPS or damage may occur.
2. From outside of the cab, lift up on the rear window and slide off the hinges. Remove the hinge washers and store in a plastic bag.

Store the rear window in a safe location to prevent damage.

To reinstall the rear window, reinstall the hinge washers, align the hinges with the pins and drop into place. Re-attach the latches to the rear leg.

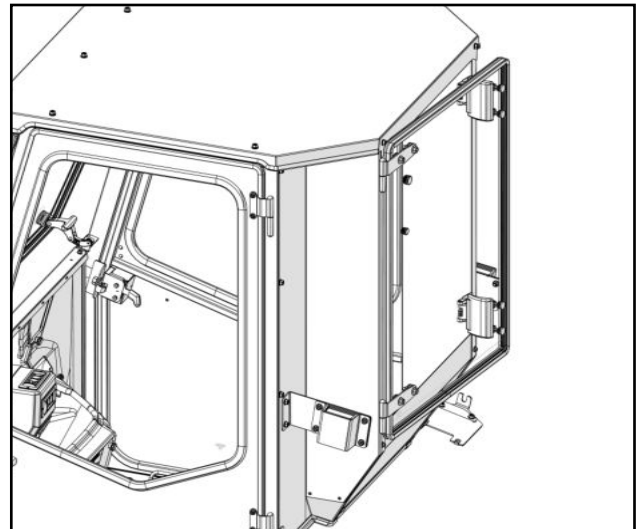

Venting/Removable Rear Window

CAB FEATURES & OPERATION

BACKHOE OPERATION

On backhoe equipped vehicles, the lower rear panel will need to be removed to operate the backhoe. Remove the Rear Window First. Then remove mounting hardware from Lower Rear Panel and store in a plastic bag.

Store the lower rear panel in a safe location to prevent damage.

Tools required

3/8" Wrench or Socket

7/16" Wrench or Socket

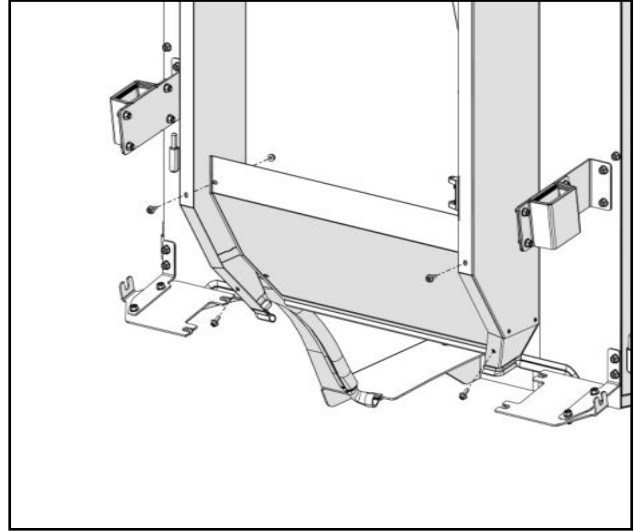

Removable Lower Rear Panel

REMOVABLE RADIATOR SHROUD PANEL

Your Workmaster 25S series cab comes equipped with a removable metal panel for extra air flow on hot summer days. Should your temperature gauge climb on a hot day, follow this procedure:

1. Make sure you provide ventilation to the cab by venting windshield, venting or removing rear window, or removing doors.
2. Remove the metal panel to allow additional air flow to the radiator.

Remove mounting hardware and store in a plastic bag.

Store the metal panel in a safe location to prevent damage.

Warning! Never remove the panel without ventilating the cab. This may cause Carbon Monoxide to be drawn into the cab. Carbon Monoxide can cause illness, serious injury, or death.

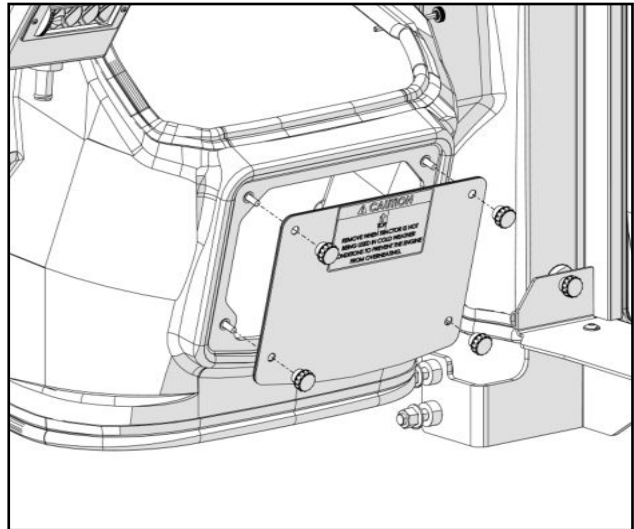

Removable Shroud Panel

REMOVABLE RADIATOR SHROUD

The radiator shroud can be removed if required for service. Below are the steps to do so:

1. Remove heater from heater bracket and let hang from hoses. (see step 16.2).
2. Disconnect heater hoses at quick disconnects, see figure 17.3.
3. Remove thumbs nuts and slide shroud backwards. See steps 4.3 and 7.2.

JUMP STARTING TRACTOR

How to jump start the tractor with Cab installed:

1. Connect red jumper to heavy gauge wire terminal on starter.
2. Connect black to frame bolt – ground.

CARE AND MAINTENANCE

- Re-apply lubrication (preferably grease) periodically as needed to the door striker pins, door latch assemblies, and the door hinges.
- Check and tighten hardware after 40 hours of operation. Periodically inspect and tighten hardware for the remainder of the unit's life.
- Wash the painted surfaces of the cab with commercial automotive cleaning products.
- Clean glass windows with glass cleaner.

NEW HOLLAND WORKMASTER 25S CAB SERVICE PARTS

ROOF ASSEMBLY
P/N: 8SV-101-00057

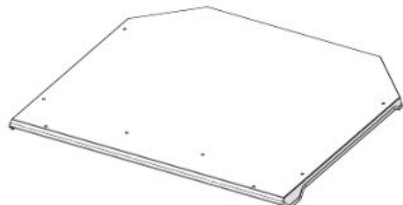

WINDSHIELD ASSEMBLY
P/N: 8SV-102-00031



WINDSHIELD SUPPORT
P/N: 8SV-103-00025



COWL ASSEMBLY
P/N: 8SV-105-00027

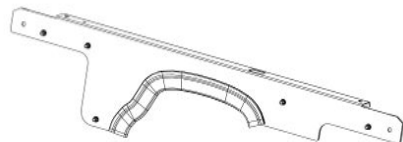

RADIATOR SHROUD ASSEMBLY
P/N: 8SV-111-00032

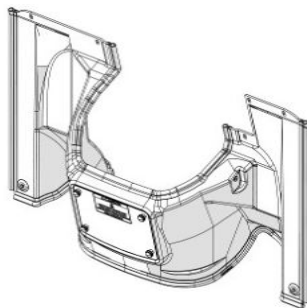

DOOR ASSEMBLY, LEFT
P/N: 8SV-107-00041-L

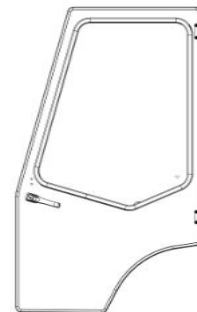

DOOR ASSEMBLY, RIGHT
P/N: 8SV-107-00041-R



REAR LEG ASSEMBLY, LEFT
P/N: 8SV-108-00023-L



REAR LEG ASSEMBLY, RIGHT
P/N: 8SV-108-00023-R

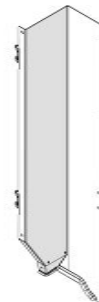

SIDE FRAME ASSEMBLY, LEFT
P/N: 8SV-109-00021-L



SIDE FRAME ASSEMBLY, RIGHT
P/N: 8SV-109-00021-R



DOOR WINDOW WITH RUBBER
P/N: 8SV-9GL-00058



NEW HOLLAND WORKMASTER 25S CAB SERVICE PARTS

ROPS CLAMP ASSEMBLY
P/N: 8SV-110-00062

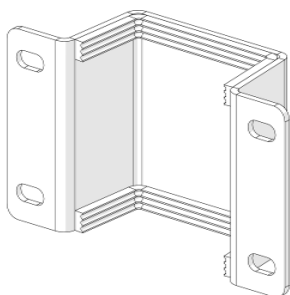

BRACKET, ROPS, ASSEMBLY, LEFT
P/N: 8SV-110-00082-L

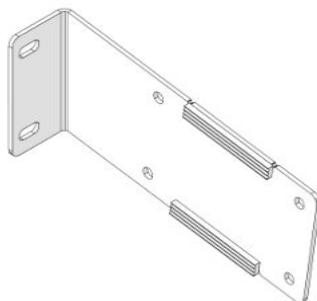

BRACKET, ROPS, ASSEMBLY, RIGHT
P/N: 8SV-110-00082-R

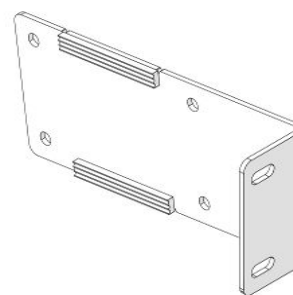

BRACKET, LOWER, REAR MOUNT
P/N: 8SV-SM-01752

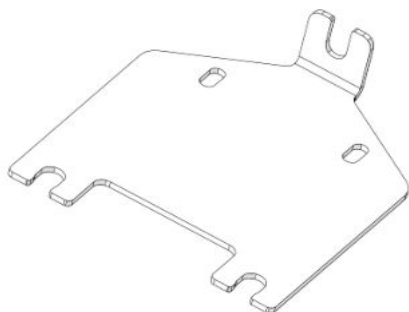

SET OF LOWER REAR MOUNTS; P/N: 8SV-SM-01753

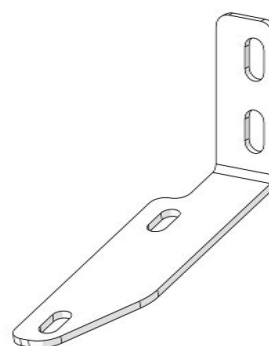
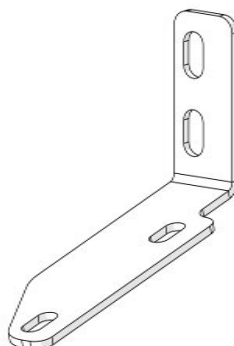

LOADER LOCK LEVER EXT BRACKET W/
INSERT; P/N: 8SV-113-00226

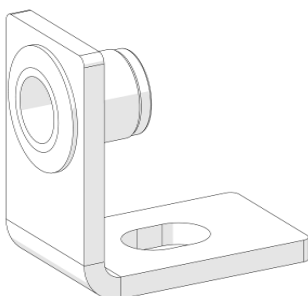

TOOL BOX OFFSET BRACKET
P/N: 8SV-SM-01776

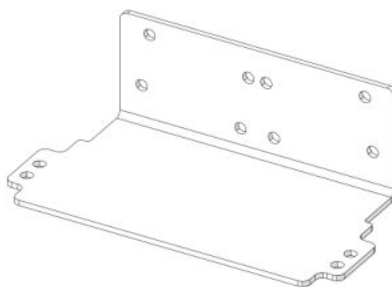

HEATER BRACKET
P/N: 8SV-SM-01756

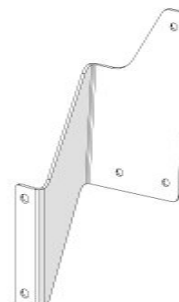

GLASS REAR PANEL LIFT OFF
P/N: 8SV-106-00021



LOWER REAR PANEL ASSEMBLY
P/N: 8SV-106-00038

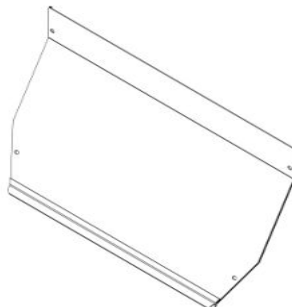

GLASS HINGE SLEEVE WITH MOUNTING
HARDWARE
P/N: 8SV-PL-00021

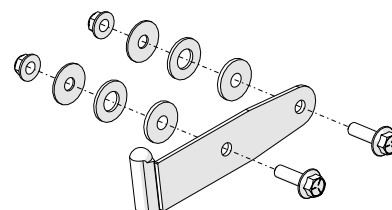

NEW HOLLAND WORKMASTER 25S CAB SERVICE PARTS

SET OF LOWER FRONT MOUNTS
P/N: 8SV-SM-01771

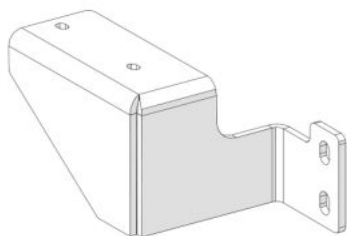
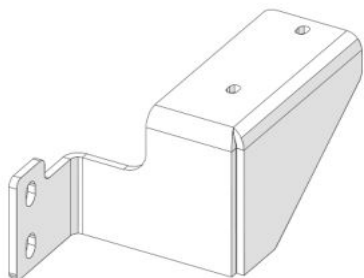

HINGE KIT, TOP & BOT, LEFT
P/N: 8SV-HKWTB-L

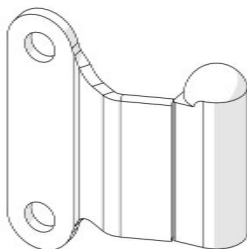
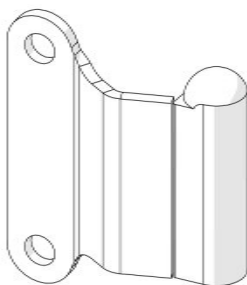

HINGE KIT, TOP & BOT, RIGHT
P/N: 8SV-HKWTB-R

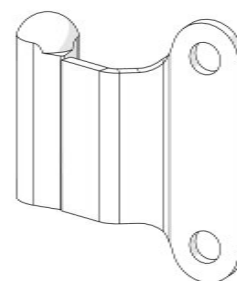
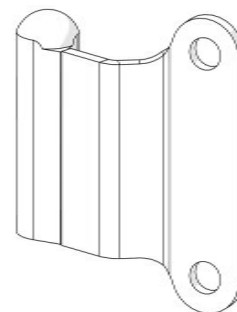

IN-LINE COUPLING, MALE INSERT
P/N: 9HR0066

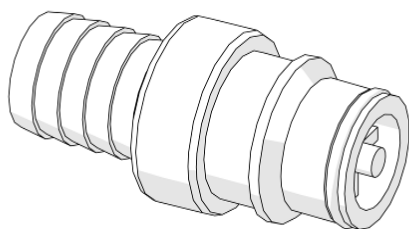

IN-LINE COUPLING, FEMALE BODY
P/N: 9HR0067

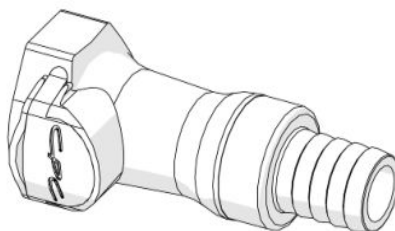

EXTENDED SENDING UNIT ADAPTER
P/N: 9HR0051MF1

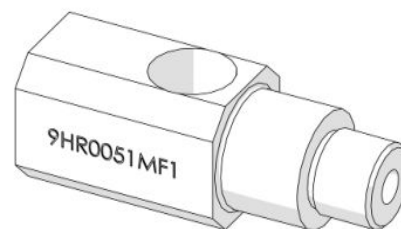



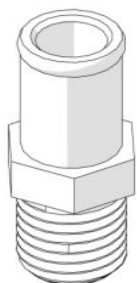



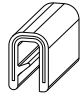

BLOCK ADAPTER (3/8" NIPPLE)
P/N: 9HR0045

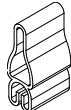

ADDITIONAL SERVICE PARTS

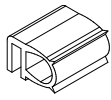
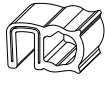
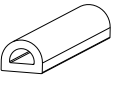
PART NUMBER	DESCRIPTION
9SV-DL173	DECAL, HEARING PROTECTION
8SV-LCH-00007	LATCH SET WITH MOUNT, POP OUT, SINGLE ARM, 3" OPENING (LEFT AND RIGHT PAIR)
9SV-9PWM110	WIPER MOTOR, 110 DEGREE
9PWB20-FB	WIPER BLADE, 20", FLEX
9SV-9PWA14-16	WIPER ARM, ADJUSTABLE LENGTH (11" - 16")
9SV-PWKHB	GLASS MOUNTING KIT FOR WIPER SYSTEMS
9SV-GS02Q	GAS SPRINGS, 12-3/8 EXT, QUICK DISCONNECT ENDS (SET OF 2)
9SV-DSTRH	DOOR STRIKER KIT - INCLUDES CASE HARDENED STRIKER BOLT
9SV-IHRL	INSIDE HANDLE ROTARY LATCH KIT (INCL. L & R)
9SV-OHRL	OUTSIDE HANDLE ROTARY LATCH KIT (SET OF 2)
9SV-9PHW010-W	HINGE WASHER, KIT (SET OF 4) OD .635, ID .41, THK .08
9SV-GS02A	BALL STUDS, 10MM (BAG OF 10)
9PI01	POLY INSERT 1", 14-20 GA BLK MATTE, INSERT FINS .94/.95 (QTY.: 1)
9PI02	POLY INSERT 3/4", 14-20 GA BLK MATTE FINISH, INSERT FINS 0.69 (QTY.: 1)
9SV-9HR00601.0	HOSE CLAMPS #10 (1") (QTY.: 6)
9SV-9HR0048	ROCKER SWITCH (HI-OFF-LOW)
9SV-9HR-L	REPLACEMENT LOUVER-15,000 & 20,000 BTU HEATER
8SV-9PH20WG	TUCK-AWAY HEATER WITH WIRED GROUND
9SV-HRH61-20	HEATER HOSE (5/8" I.D.)-20 FT
9SV-TBP12920	HARNESS (SPIRAL) WRAP, CUT 20"
9SV-WH-00072	WIRING HARNESS POWER
8SV-WH-GF	WIRE HARNESS, GLASS FUSE
9DL01H	KEYS, SET OF 2 ON A RING, FOR HANDLE 1096-1, KEY CODE C40

<p>TRIM LOK, STD, 1/16" - 1/8" GRIP</p>  <p>9SV-PRO1-20</p>	<p>5/8" STD BULB, 1/16" GRIP</p>  <p>9SV-PRO2-15</p>	<p>1" FLAT BULB, 1/16" GRIP</p>  <p>9SV-PRO5-10</p>	<p>1/2" WEATHERSEAL</p>  <p>9SV-PR20-10</p>	<p>WINDOW RUBBER</p>  <p>9SV-PR10-10</p>	<p>1" ROUND BULB, 1/16" GRIP</p>  <p>9SV-PR19-10</p>	<p>3/4" SIDE BULB, 1/16" GRIP</p>  <p>9SV-PR17-20</p>	<p>3/4" SIDE BULB, 1/4" GRIP</p>  <p>9SV-PR38-15</p>	<p>ARCH PSA .2 X .15</p>  <p>9SV-PR53-15</p>	
					<p>5/8" STD BULB, 1/4" GRIP</p>  <p>9SV-PRO7-5</p>				

OPTIONAL ACCESSORIES FOR NEW HOLLAND WORKMASTER 25S CAB

FRONT LED WORK LIGHTS (P/N: 9LEDW4)

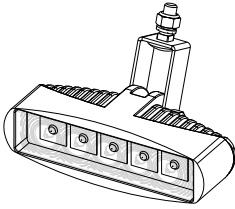

REAR LED WORK LIGHTS (P/N: 9LEDW3)

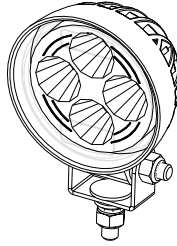

STROBE LIGHT (P/N: 9LEDS2)

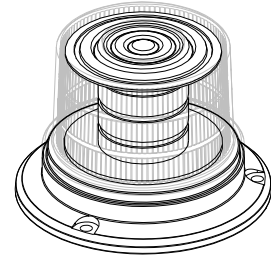

DOME LIGHT (P/N: 9LEDD14)

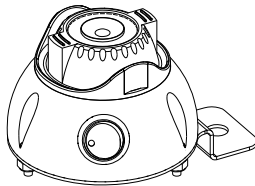

SIDE VIEW MIRRORS (P/N: 9PM5)

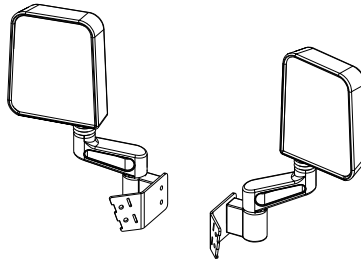

REAR VIEW MIRROR (P/N: 9PM3)

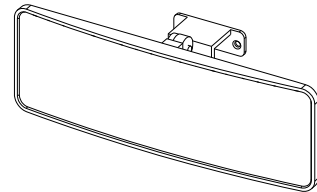

REAR WIPER KIT, 85 DEG W/ 12" FLEX BLADE (P/N: 9PWK8512F9-11A)

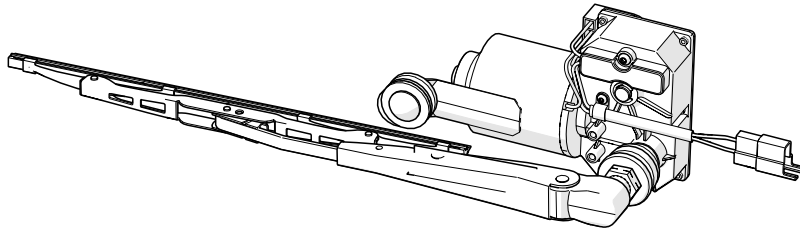

SEAL KIT (P/N: 9SK8)

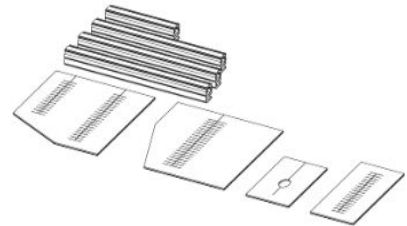

Tightening of Non-Structural Bolts

For light or medium duty fastening, Curtis recommends using a general industry standard of tightening until snug and then giving an additional one quarter turn of the tool as deemed reasonable for the application (i.e.: at the installer's discretion).

If torque values are required, the examples listed below are intended as a reasonable reference for use in the majority of non-structural fastener applications such as: small diameter fasteners; bolts passing thru tubing, glass, plastic, nylon or rubber washers, threaded inserts, etc.

If more than one application below applies, use the lower torque value.



FASTENER SIZE:	FASTENER TYPE:	WASHER MATERIAL:	APPLICATION:	TORQUE (INCH-POUNDS) (±5)
#10	Machine Screws	-	in Nylon P-Clamps	20
#10	Machine Screws	-	Strobe Light (plastic base)	35
M5	Set Screws	-	Wiper Arm	20
1/4"	Cap Nut	-	Windshield Wiper	20
1/4"	Bolts	-	Tubing (5/8" to 3/4" wide)	132
1/4"	Bolts	Rubber	-	60
1/4"	Bolts	Nylon / Plastic	-	72
1/4"	Bolts	-	Factory Installed Threaded Inserts	132
5/16"	Bolts	-	Tubing (1" or wider)	60
5/16"	Flat Head Bolts	-	Plastic Windshield Hinge	79
5/16"	Bolts	Rubber	-	120
5/16"	Bolts	Nylon / Plastic	-	150
5/16"	Ball Studs	-	-	150
5/16"	Bolts	-	Factory Installed Threaded Inserts	240
3/8"	Bolts	-	Tubing	120
M12	Door Striker Pins	-	-	120

Torque Specs. for Structural Bolts

This page is for use primarily when dealing with high-strength vehicle fasteners such as ROPS hardware that hold the structure together for safety. This page can also be used for other solid metal-to-metal joints. **Do not** use these high torque values on any of the following applications involving: tubing, plastic, nylon or rubber washers, threaded inserts, etc.. See previous page regarding less critical fasteners.

The values below apply to fasteners that are dry or lubricated with normal engine oil. They do not apply if special graphited or moly disulphide greases or other extreme pressure lubricants are used. This applies to both UNF and UNC threads. Remember to always use the same grade or property class when replacing bolts.

IMPORTANT: on all PLATED GRADE 8 bolts, reduce torque 15% from listed bolt torque specification.

SAE Grade No.		2				5				8*			
Bolt head identification mark as per grade. NOTE: Manufacturing Marks Will Vary													
		TORQUE		TORQUE		TORQUE		TORQUE		TORQUE		TORQUE	
Bolt Size		Pounds Feet		Newton-Meters		Pounds Feet		Newton-Meters		Pounds Feet		Newton-Meters	
Inches	Millimeters	Min.	Max.	Min.	Max.	Min.	Max.	Min.	Max.	Min.	Max.	Min.	Max.
1/4	6.35	5	6	7	8	9	11	12	15	12	15	16	20
5/16	7.94	10	12	14	16	17	20.5	23	28	24	29	33	39
3/8	9.53	20	23	27	31	35	42	48	57	45	54	61	73
7/16	11.11	30	35	41	47	54	64	73	87	70	84	95	114
1/2	12.70	45	52	61	70	80	96	109	130	110	132	149	179
9/16	14.29	65	75	88	102	110	132	149	179	160	192	217	260
5/8	15.88	95	105	129	142	150	180	203	244	220	264	298	358
3/4	19.05	150	185	203	251	270	324	366	439	380	456	515	618
7/8	22.23	160	200	217	271	400	480	542	651	600	720	814	976
1	25.40	250	300	339	406	580	696	787	944	900	1080	1220	1464
1-1/8	25.58	-	-	-	-	800	880	1085	1193	1280	1440	1736	1953
1-1/4	31.75	-	-	-	-	1120	1240	1519	1681	1820	2000	2468	2712
1-3/8	34.93	-	-	-	-	1460	1680	1980	2278	2380	2720	3227	3688
1-1/2	38.10	-	-	-	-	1940	2200	2631	2983	3160	3560	4285	4827

*Thick Nuts must be used with Grade 8 bolts

METRIC BOLT TORQUE SPECIFICATIONS



Size of Screw	Property Class	Course Thread			Fine Thread		
		Pitch (mm)	Pounds Feet	Newton-Meters	Pitch (mm)	Pounds Feet	Newton-Meters
M6	5.6	1.0	3.6-5.8	4.9-7.9	-	-	-
	8.8		5.8-9.4	7.9-12.7		-	-
	10.9		7.2-10	9.8-13.6		-	-
M8	5.6	1.25	7.2-14	9.8-19	1.0	12-17	16.3-23
	8.8		17-22	23-29.8		19-27	25.7-36.6
	10.9		20-26	27.1-35.2		22-31	29.8-42
M10	5.6	1.5	20-25	27.1-33.9	1.25	20-29	27.1-39.3
	8.8		34-40	46.1-54.2		35-47	47.4-63.7
	10.9		38-46	51.5-62.3		40-52	54.2-70.5
M12	5.6	1.75	28-34	37.9-46.1	1.25	31-41	42-55.6
	8.8		51-59	69.1-79.9		55-68	75.9-92.1
	10.9		57-66	77.2-89.4		62-75	84-101.6
M14	5.6	2.0	49-56	66.4-75.9	1.5	52-64	70.5-86.7
	8.8		81-93	109.8-126		90-106	122-143.6
	10.9		96-109	130.1-147.7		107-124	145-168
M16	5.6	2.0	67-77	90.8-104.3	1.5	69-83	93.6-112.5
	8.8		116-130	157.2-176.2		120-138	162.6-187
	10.9		129-145	174.8-196.5		140-158	189.7-214.1
M18	5.6	2.0	88-100	119.2-136	1.5	100-117	136-158.5
	8.8		150-168	203.3-227.6		177-199	239.8-269.6
	10.9		175-194	237.1-262.9		202-231	273.7-313
M20	5.6	2.5	108-130	146.3-176.2	1.5	132-150	178.9-203.3
	8.8		186-205	252-277.8		206-242	279.1-327.9
	10.9		213-249	288.6-337.4		246-289	333.3-391.6