



**E-Z-GO RXV
Climate Control
StreetPro SE**
Beige (p/n: 1GCRXV1)
Black (p/n: 1GCRXV2)
Ivory (p/n: 1GCRXV3)
Security (Black & Ivory) (p/n: 1GCRXV4)
White (p/n: 1GCRXV5)

The contents of this envelope are the property of the owner.
Be sure to leave with the owner when installation is complete.

APPROXIMATE INSTALLATION TIME: ONE HOUR
(excluding accessories)



This cab is covered by one or more of the following patents and others pending:
U.S.: 7429072, 7219948, 7281753, D555058, D547697, D542711, D557191.
CAN.: 112130. U.K.: 3022131, 3022412, 3022411, 3022410, 2434126.
Curtis Industries, LLC.

DESIGN CONCEPT





Curtis Cabs feature an assembly of parts designed for your vehicle which require adjustment and alignment of components to accommodate vehicle variations and provide proper weather protection. For accurate installation, proper operation, and years of satisfaction, please read and understand the installation instructions.

From all of us at Curtis, we thank you for choosing our product.

GENERAL INFORMATION

Helpful Reminders:

- A. Leave all bolts loose for later adjustment unless otherwise specified.
- B. Read and understand all instructions before beginning.

 WARNING	
Serious Injury or Death	
	This cab enclosure does not provide protection from rollover or other accidents.
	This cab enclosure does not provide protection from flying objects including golf balls.
	This cab enclosure does not provide protection from lightning. When lightning threatens take cover and do not operate vehicle.

 NOTICE: ADDITIONAL WEIGHT
<i>This enclosure adds 110 lbs. to the weight of the vehicle.</i>

DANGER!

Battery—Explosive Gases. Do not smoke. Keep sparks and flames away from the vehicle and service area. Service only in a well-ventilated area.

Battery—Poison! Contains acid! Causes severe burns! Avoid contact with skin, eyes, or clothing. Wear a full face shield and rubber gloves when working on or near batteries. If contact occurs: External—Flush with water. Call physician immediately.

Internal—Drink large quantities of milk or water. Follow with milk of magnesia or vegetable oil. Call physician immediately.

Eyes—Flush with water for 15 minutes. Call a physician immediately.

Battery—While charging, be sure that a door, the rear curtain, or the windshield is open.

Gasoline—Flammable! Explosive! Do not operate gasoline vehicle in an enclosed area without proper ventilation. The engine produces carbon monoxide, which is an odorless, deadly poison.

This vehicle and enclosure will not provide protection from rollover, flying objects including golf balls, lightning, or other hazards. If caught in a storm, exit the vehicle and seek shelter in accordance with applicable safety guidelines for your location.

WARNING!

Only trained technicians should service or repair the enclosure. Anyone doing repairs or service should have knowledge and experience in electrical and mechanical repair. The appropriate instructions must be used when performing maintenance, service, or installation.

Follow the procedures exactly as stated in these instructions, and heed all DANGER, WARNING, and CAUTION statements both in this instruction manual as well as those posted on the vehicle.

Prior to servicing the vehicle, turn the key switch to OFF and set the parking brake.

Always wear safety glasses or approved eye protection when servicing the vehicle.

Moving parts! Do not attempt to service the vehicle while it is running.

Hot! Do not attempt to service while engine, exhaust system, or motor are hot. Failure to heed this warning could result in severe burns.

Use insulated tools when working near batteries or electrical connections. Avoid shorting components or wiring.

If wires are removed or installed, make sure wiring and wire harness are properly routed and secured. Failure to properly route and secure wiring could result in vehicle malfunction, property damage, personal injury, or death.

E-Z-GO RXV

DOOR PARTS

① Right Door with Frame Assembly Complete

② Left Door with Frame Assembly Complete

③ Right Outer Door Skin with No Frame Complete

④ Left Outer Door Skin with No Frame Complete

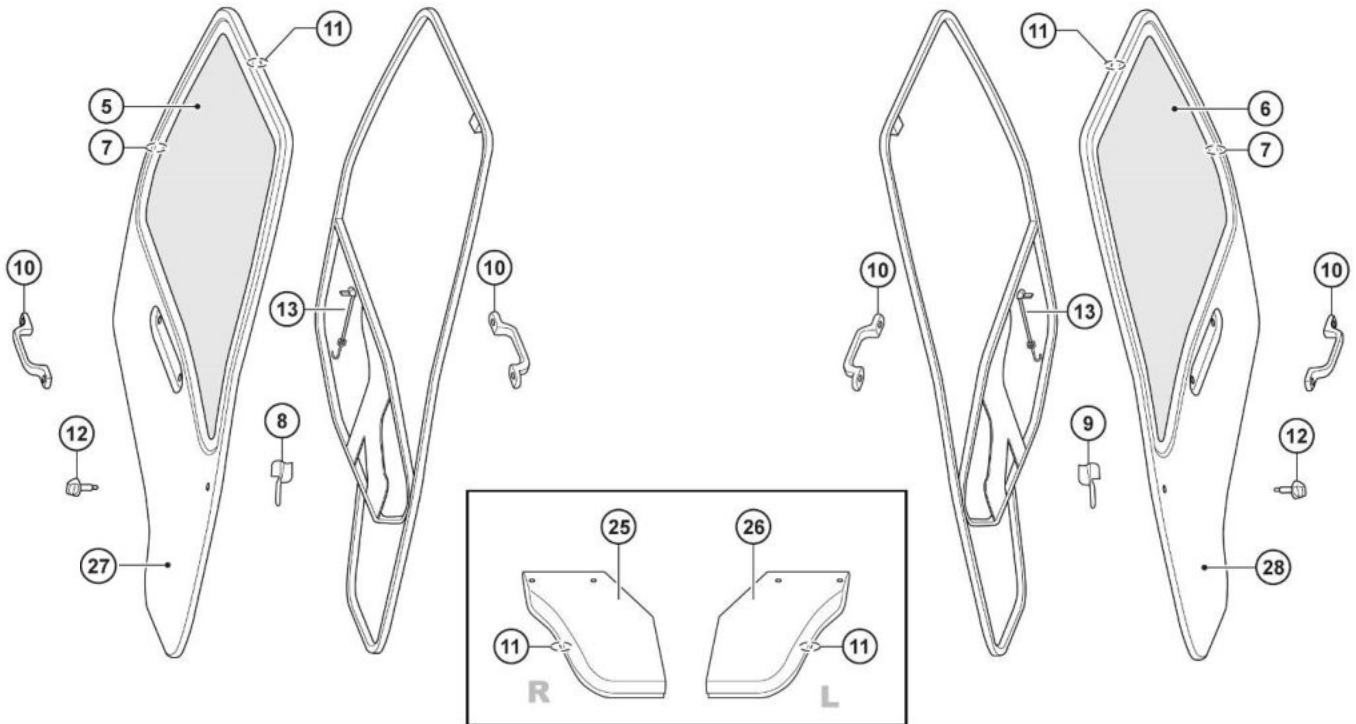

⑮ 4-Leaf Hinge Set Complete

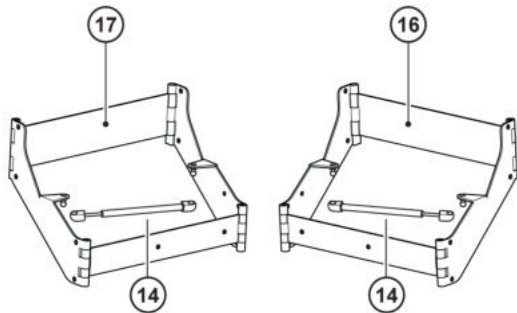

⑳ Top L Hinge Assy Complete ㉑ Top R Hinge Assy Complete

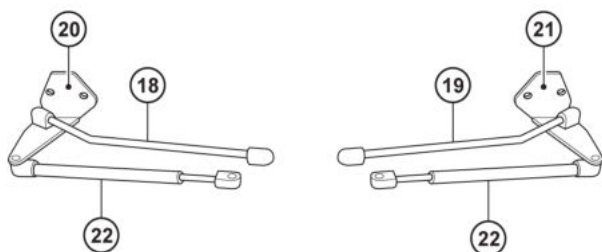

REF #	P/N	DESCRIPTION
1	8SV-RXV7RW 8SV-RXV7RB 8SV-RXV7RBK	Right Door Assembly Complete (White) Right Door Assembly Complete (Beige) Right Door Assembly Complete (Black)
2	8SV-RXV7LW 8SV-RXV7LB 8SV-RXV7LBK	Left Door Assembly Complete (White) Left Door Assembly Complete (Beige) Left Door Assembly Complete (Black)
3	8SV-RXV07DSRW 8SV-RXV07DSRB 8SV-RXV07DSRBK	Right Door Skin Assembly (White) Right Door Skin Assembly (Beige) Right Door Skin Assembly (Black)
4	8SV-RXV07DSLW 8SV-RXV07DSLB 8SV-RXV07DSLBK	Left Door Skin Assembly (White) Left Door Skin Assembly (Beige) Left Door Skin Assembly (Black)
5	8SV-PGCC2R	Right Door Window w/ Mounting Rubber
6	8SV-PGCC2L	Left Door Window w/ Mounting Rubber
7		Molded Acrylic Mounting Rubber (Sold with Windows #5 & #6)
8 & 9	9SV-DLGC	Interior Latch Kit (Set of 2)
10	9SV-GH	Grab Handle Kit (Set of 2)
11	9SV-PR32-15	Door Edge Rubber (15" Length)
12	9SV-DLSGC	Door Knob (Set of 2)
13	9SV-GCYDBC	Bungee Cord Assembly Kit (Set of 2)
14	9SV-GS05	100N Gas Spring Kit (Set of 2)
15	9SV-HDR4L	Hinge Kit (1 Left, 1 Right)
16		Right Hinge Assembly (Sold in Hinge Kit #15)
17		Left Hinge Assembly (Sold in Hinge Kit #15)
18 & 19	9SV-HRGC	Hinge Rod Kit (1 Left, 1 Right)
20 & 21	8SV-GCHPLR-B5	Top Hinge Pivot Kit (1 Left, 1 Right)
22	9SV-GS04	75N Gas Spring Kit (Set of 2)
23	8SV-CC1L	Left Top Hinge Assembly Complete
24	8SV-CC1R	Right Top Hinge Assembly Complete
25		Right Plastic Door Flap (Sold in Right Door Assembly #1)
26		Left Plastic Door Flap (Sold in Left Door Assembly #2)
27		Right Door Skin (Sold in Right Door Skin Assembly #3)
28		Left Door Skin (Sold in Left Door Skin Assembly #4)

E-Z-GO RXV

SIDE FRAME PARTS

① Right Side Frame including F & R Panels, Header and Rubber , No Door

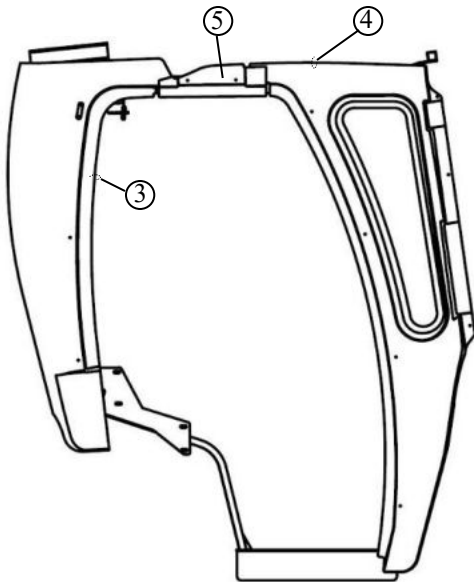

② Left Side Frame including F & R Panels, Header and Rubber , No Door

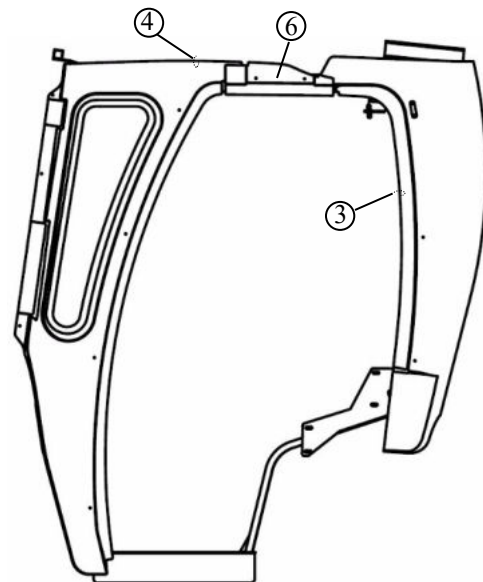

⑦ Left Front Panel Complete ⑧ Right Front Panel Complete

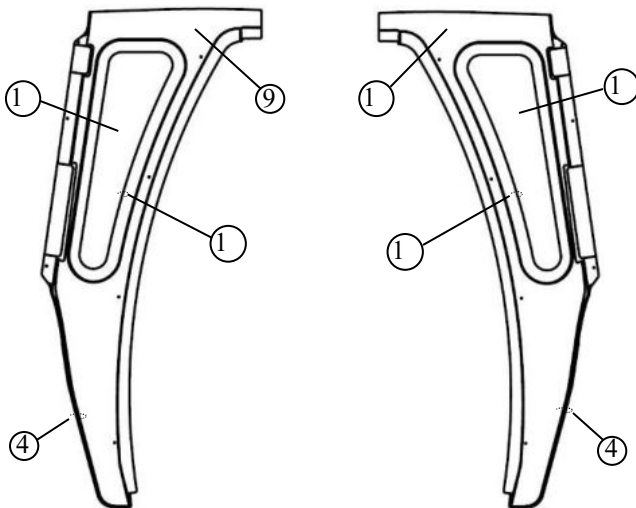

⑭ Right Rear Panel Complete ⑮ Left Rear Panel Complete

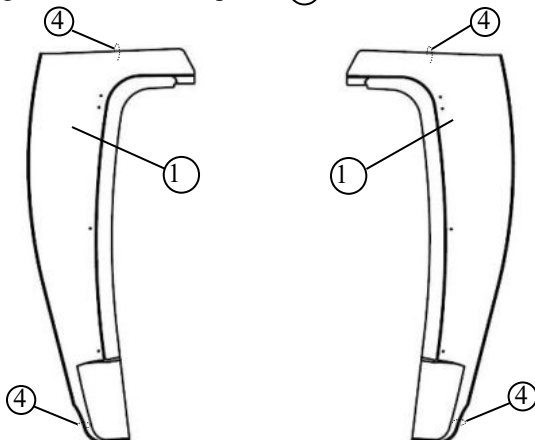

REF #	P/N	DESCRIPTION
1	8SV-RXV19RW 8SV-RXV9RB 8SV-RXV9RBK	Right Side Frame Assembly Complete (White) Right Side Frame Assembly Complete (Beige) Right Side Frame Assembly Complete (Black)
2	8SV-RXV19LW 8SV-RXV9LB 8SV-RXV9LBK	Left Side Frame Assembly Complete (White) Left Side Frame Assembly Complete (Beige) Left Side Frame Assembly Complete (Black)
3	9SV-PRO1-10	Standard Trim Lock (10' Length)
4	9SV-PR19-10	1" Round Bulb Rubber (10' Length)
5		Left Door Header (Sold with Right Side Frame Assembly #1) (Beige, White, or Black)
6		Right Door Header (Sold with Left Side Frame Assembly #2) (Beige, White, or Black)
7	8SV-RXV104LW 8SV-RXV04LB 8SV-RXV04LBK	Left Front Panel Complete (White) Left Front Panel Complete (Beige) Left Front Panel Complete (Black)
8	8SV-RXV104RW 8SV-RXV04RB 8SV-RXV04RBK	Right Front Panel Complete (White) Right Front Panel Complete (Beige) Right Front Panel Complete (Black)
9		Left Front Panel Skin (Sold with Left Front Panel #7)
10		Right Front Panel Skin (Sold with Right Front Panel #8)
11	8SV-IARXVFWL	Left Front Window w/ Mounting Rubber
12	8SV-IARXVFWR	Right Front Window w/ Mounting Rubber
13		Ball Cage Rubber (Sold with Windows #11 & #12)
14	8SV-RXV106LW 8SV-RXV06LB 8SV-RXV06LBK	Left Rear Panel Complete (White) Left Rear Panel Complete (Beige) Left Rear Panel Complete (Black)
15	8SV-RXV106RW 8SV-RXV06RB 8SV-RXV06RBK	Right Rear Panel Complete (White) Right Rear Panel Complete (Beige) Right Rear Panel Complete (Black)
16		Left Rear Panel Skin (Sold with Left Front Panel #14)
17		Right Rear Panel Skin (Sold with Right Rear Panel #15)

This list is to be used for ordering service parts. DO NOT DISCARD.

E-Z-GO RXV

STANDARD PARTS (cont'd.)

REF	#P/N	DESCRIPTION
1	8SV-RXV03URC-VR	Upper Rear Curtain
2	8SV-RXV03LRC-VC	Lower Rear Curtain
3	8SV-RXV03FDP-VD	Front Draft Panel (w/Velcro)
4	8SV-RXV03FCF-VD	Cowl Filler (w/Velcro)

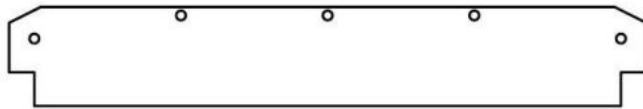

③ Front Draft Panel

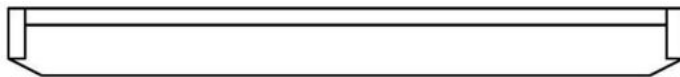

④ Cowl Filler

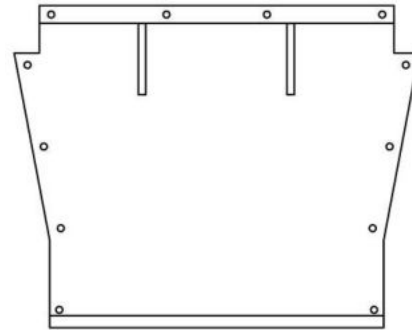

① Upper Rear Curtain

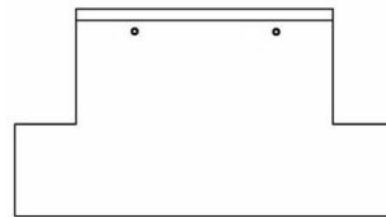

② Lower Rear Curtain

HARDWARE KIT (p/n: EZRXV-HWK):



#10 x 3/4"
PHILLIPS
SELF-DRILL/
TAP SCREW



1/2" P-CLIP

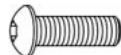

3/8-16 x 3-1/4"
3/8-16 x 3-3/4"
BUTTON HEAD
BOLTS



3/8" STEEL
WASHERS



3/8-16 NYLON
LOCKNUTS



#8
SELF-
TAPPING
STUD
SNAP

TOOLS REQUIRED:

OPEN END WRENCHES (METRIC AND SAE)
 RATCHET AND SOCKETS (METRIC AND SAE)
 ALLEN WRENCHES (METRIC AND SAE)
 TORX WRENCHES
 SCREWDRIVER (PHILLIPS HEAD)
 ELECTRIC DRILL AND 6" PHILLIPS HEAD BIT
 TAPE MEASURE
 FINE POINT ERASABLE MARKER
 SCISSORS

1. VEHICLE PREP

1.1 Per fig. 1.1, remove and discard two original equipment bolts and nuts from the rear roof area on the passenger's side as shown. Note: the small inset photo shows the hardware. New, longer hardware is provided. Repeat for driver's side.

1.2 Per fig. 1.2, remove and discard one original equipment bolt and nut from the front roof area on the passenger's side as shown. New, longer hardware is provided. Repeat for driver's side.

1.3 Per fig. 1.3, remove and save two special original equipment plastic thread cutting screws as shown. Note: the small inset photo shows one of the screws. Repeat for driver's side. Note: these special screws will be reused in step 5.1 on page 11.

1.4 Per fig. 1.4, loosen four bolts from behind the seat area as follows: the two bolts marked "a" can be loosened approximately 1/2" out. The two bolts marked "b" need only be loosened one or two turns (1/8"). No need to fully remove any of these bolts. Repeat for driver's side.

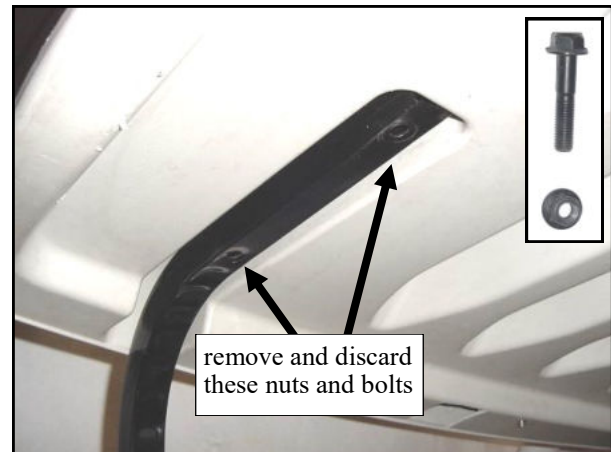

Fig. 1.1 (view taken from front of passenger's side)



Fig. 1.2 (view taken from rear of passenger's side)



Fig. 1.3 (view taken from passenger's side)

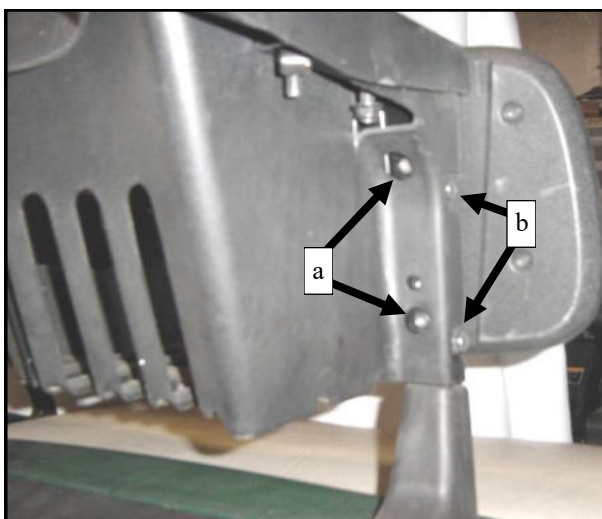

Fig. 1.4 (view taken from rear of passenger's side)

2. INSTALLING SNAPS

2.1 Per fig. 2.1, remove the roof from the vehicle and lay it on a protected surface with the inner surface (marked "c" in the photo) facing up in preparation for self-tapping snaps (see fig. 2.1.1). Orient the roof as illustrated on the next page (rear up top and front down bottom to match the page layout) then return to step 2.2 below.

2.2 Per fig. 2.1 and the dimensioned sketch of the roof on the next page, nine (9) self-tapping snaps are to be installed on the under side of the plastic roof (five in front and four in the back for use with the front draft panel and the upper rear curtain).

2.3 Per the dimensioned sketch on the next page, use a fine pointed, erasable marker to layout the locations on the inside rear surface of the plastic roof. All four center marks are to be in an arc formation $3/4$ " up from the contoured edge shown. Starting from the approximate center of the roof (represented by the centerline) mark out $4-1/4$ " and 14 " as shown. The center to center dimensions between marks are to be $8-1/2$ " and $9-3/4$ " respectively. Double check these dimensions before installing the self-tapping snaps in step 2.5.

2.4 The center marks for the inside front surface of the roof are to be $8-3/4$ " and $17-1/8$ " off the approximate centerline and in an arc formation $3/4$ " down from the contoured edge shown. Double check that the center to center distances are $8-3/8$ " and $8-3/4$ " respectively before installing the self-tapping snaps in the next step.

2.5 Use a Phillips head screwdriver or a Torx wrench to manually install nine (9) self-tapping snaps in the plastic roof using caution to avoid over-tightening. No power tool required and no pilot hole required. **Note: do not over-tighten. Over-tightening can lead to stripping out the newly cut plastic threads.**

2.6 Leave the roof off of the vehicle until the side frames have been installed in the next step (step 3 on page 10).

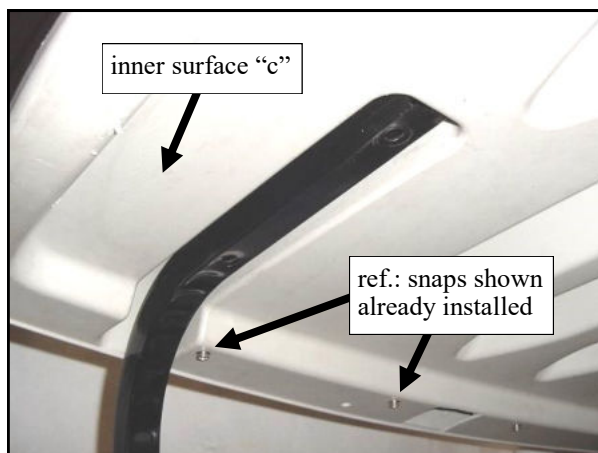
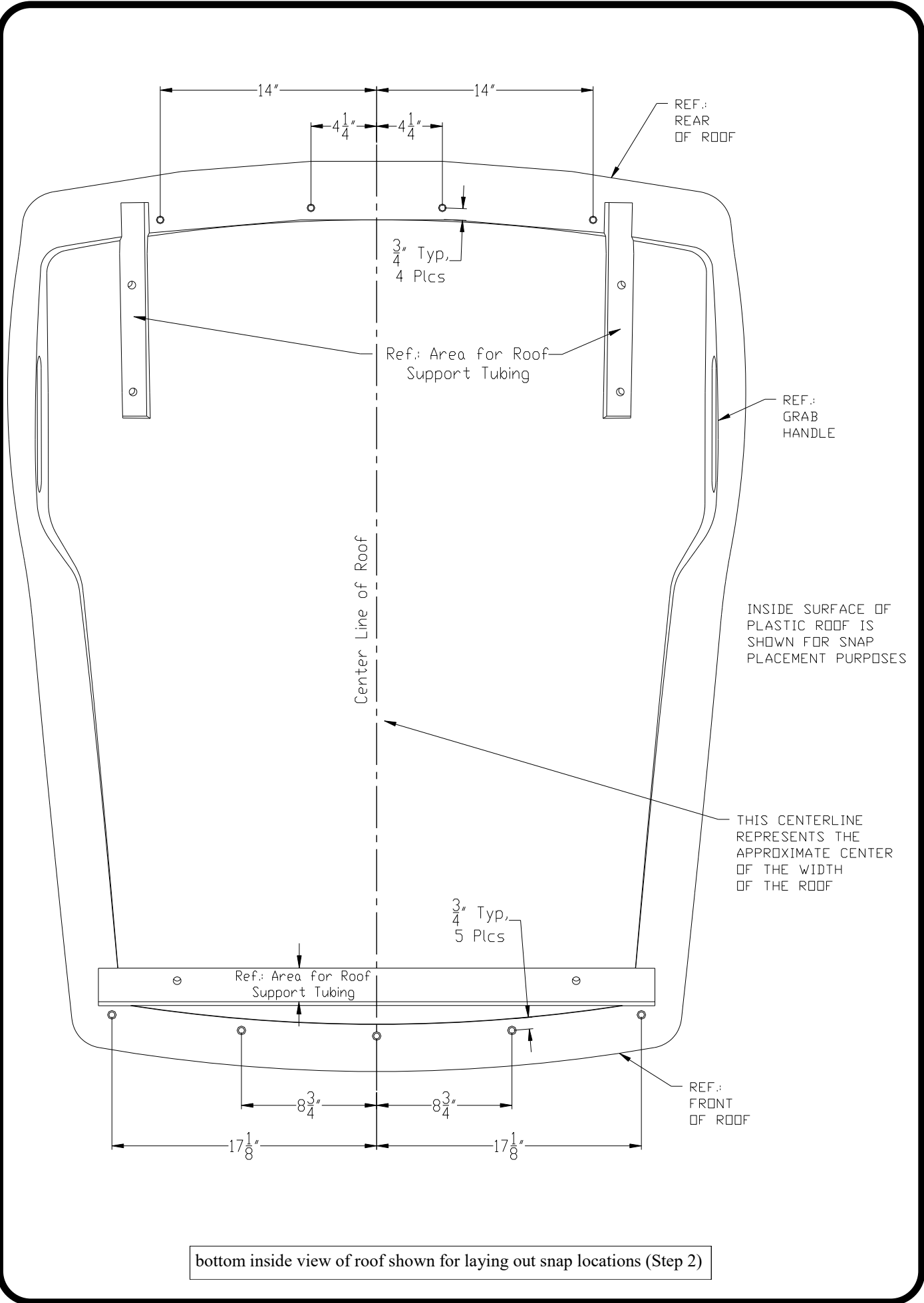

Fig. 2.1 (view taken from front of passenger's side)



Fig. 2.1.1 (self-tapping snap)



bottom inside view of roof shown for laying out snap locations (Step 2)

3. SIDE FRAME ASSEMBLY

3.1 Cut the supplied Expand-a-foam into two pieces that are 29" long. With assistance, position the driver's side side side frame assembly upside down so the floorboard is up as shown in fig. 3.1. Note: for clarification, the Expand-a-foam is represented by a heavy white line in the photo. Install one 29" long piece of Expand-a-foam to the in-board surface of the tubing as shown. Note: self-adhesive foam should be applied to a clean, dry surface at room temperature for best adhesion. Begin the installation near the floorboard (a) and end it at approximately point c where shown. Note: the expand-a-foam can take up to 24 hours to expand out to its full 2". This process can be speeded up, or aided by applying heat with a heat gun or similar appliance. Repeat for opposite side frame assembly (passenger's side).

3.2 With assistance, install the passenger's side side frame assembly on to the vehicle by first placing the floorboard of the side frame assembly onto the floor of the vehicle, positioning the front portion of the front panel in place first (inside the front roof support tube), then swinging the back side into place. The lower rear panel and slotted mount should sandwich between the seat back and the frame. See figures 3.2, 3.2.1, and 3.2.2. When done fitting it up, temporarily install a drift pin, a screwdriver, or one of the long bolts provided into the vertical through holes in the top front corner to prevent the passenger's side side frame assembly from falling while working on the driver's side. Install the driver's side side frame assembly.

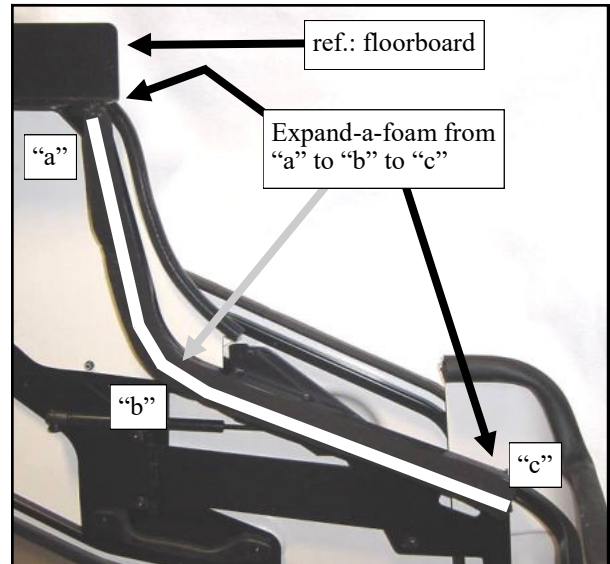

Fig. 3.1 (view of upside down driver's side assembly)

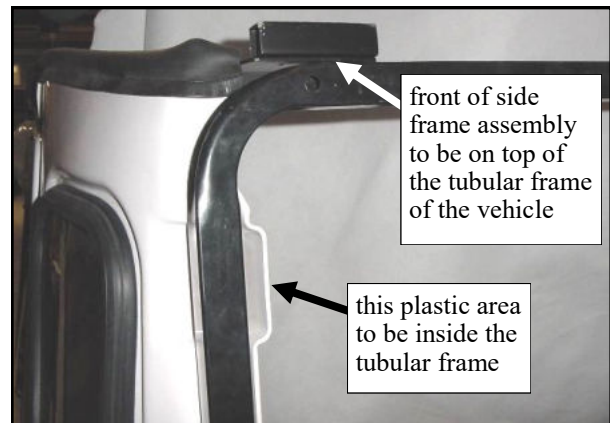

Fig. 3.2 (view taken from front of passenger's side)

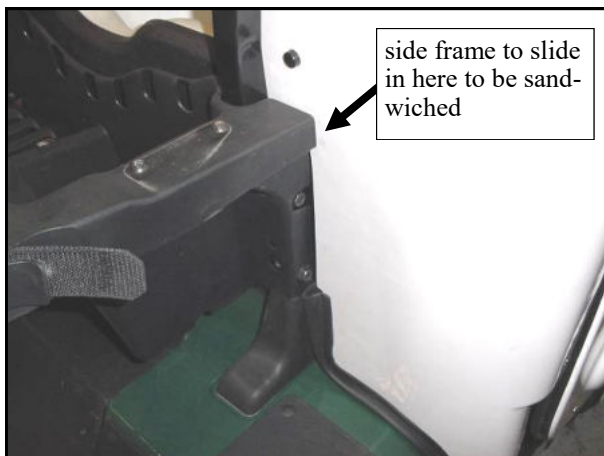

Fig. 3.2.2 (view taken from rear of passenger's side)

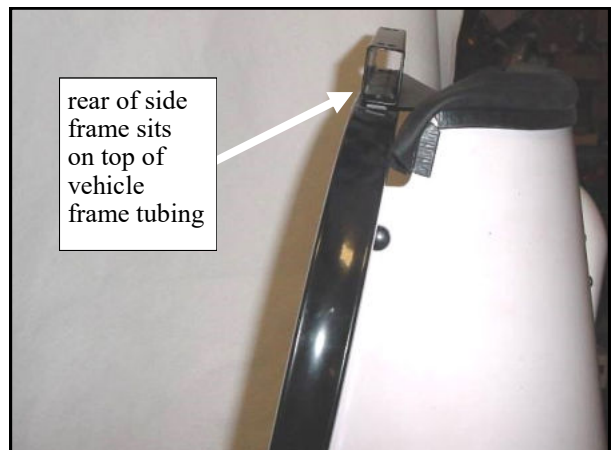

Fig. 3.2.1 (view taken from rear of passenger's side)

4. ROOF

4.1 Remove any drift pins, screwdrivers, or temporary bolts used to hold the side frames in place. Per fig. 4.1, re-install the roof oriented so the large oval openings (grab handles) are towards the back half of the vehicle. Use the new, longer bolts, washers, and locknuts provided. In each of the two front corners, use one 3/8-16 x 3-1/4" long button head bolt, two flat steel washers, and one locknut. Note: the longer 3-3/4" bolts are for the rear corners. The bolts should feed down thru the roof, thru the side frame assembly, then the roof support tube, and then a washer and locknut loosely installed on to the bolts. Leave bolts loose.

4.2 In each of the two rear corners, use two 3/8-16 x 3-3/4" long button head bolts, four flat steel washers, and two locknuts. The bolts should feed down thru the roof, thru the side frame assembly, then the roof support tube, and then a washer and locknut loosely installed on to the bolts. Leave bolts loose.

5. BOLT TIGHTENING

5.1 Per fig. 5.1, re-install the special, original equipment screws through the sheet metal slots and into the floorboard (two per side as shown). **CAUTION: these thread into plastic. Do not over-tighten. Over-tightening may damage the plastic threads and cause them to strip out.** Repeat for driver's side.

5.2 Tighten the front corner roof bolts next. One per corner for a total of two. Do not over-tighten. Over-tightening may damage (crush) the tubing and damage the plastic roof.

5.3 Tighten the rear corner roof bolts. Two per corner for a total of four. Do not over-tighten. Over-tightening may damage (crush) the tubing and damage the plastic roof.

5.4 Per fig. 5.4, tighten the bolts located behind the seat as shown (locations a and b) (four per side for a total of eight).

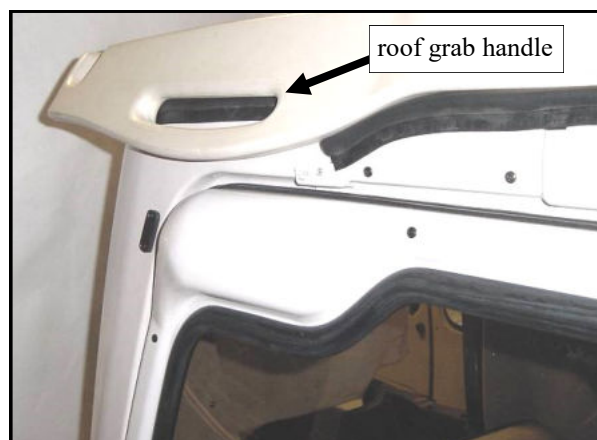

Fig. 4.1 (view taken from front of passenger's side)



Fig. 5.1 (view taken from passenger's side)

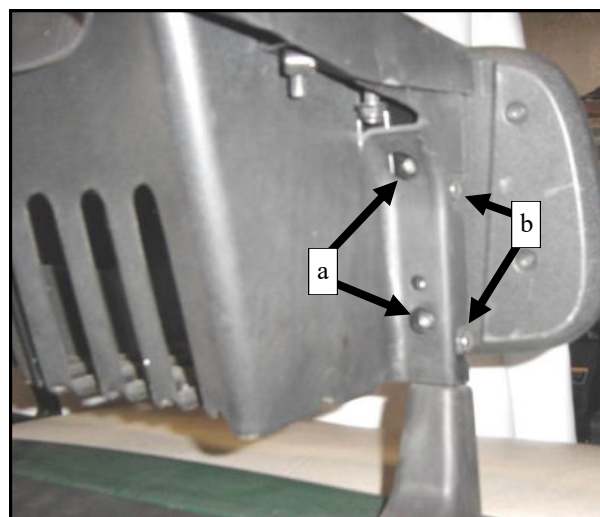

Fig. 5.4 (view taken from rear of passenger's side)

6. FRONT PANELS

6.1 Per fig. 6.1, secure the plastic front panels to the vertical roof support tubing using three (3) self-drilling/self-tapping screws on the driver's side. Note: the black circles in the photo represent the screws. Note: no pilot hole required. An electric drill with a Phillips head bit can be used. Do not over-tighten. Over-tightening can cause the threads to strip out of the thin walled tubing. Repeat for passenger's side.

7. FRONT DRAFT PANEL

7.1 Reminder: adhesive backed velcro should be applied to a clean, dry surface at room temperature for best adhesion. Per the important cleaning information located on page 18, never use an alcohol-based product for cleaning acrylic windshields. Do not use Windex, Glass Plus, Fantastic, etc.. Use of these products will result in deterioration of the acrylic. Per fig. 7.1, install a 35" long piece of velcro to the bottom side of the narrow bent portion of the upper windshield as shown. Place it close to the bend and right over the long, oval slots. Fig. 7.1.1 shows the windshield in a different orientation (semi-open). On the driver's side, there is a large radius cutout. At the installer's discretion, the velcro can be cut to match the radius or left unaltered (full width).

7.2 Per fig. 7.2, install the front draft panel by engaging all five (5) snaps as shown. Note: orient the black vinyl so the lower flap opening is as shown.

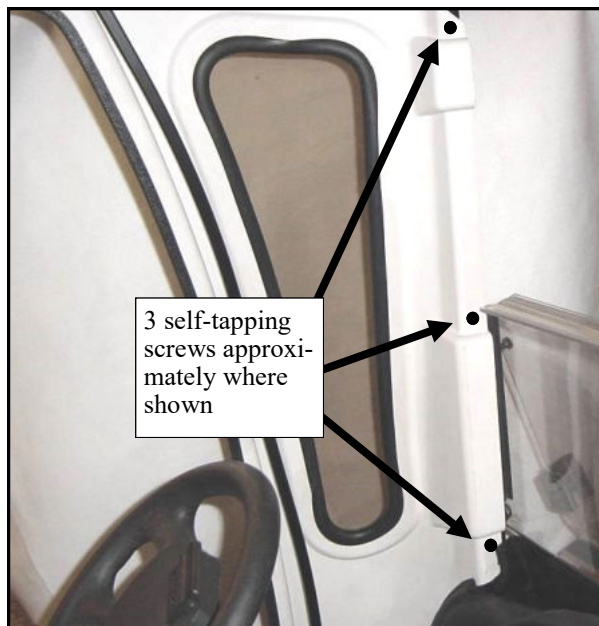

Fig. 6.1 (inside view of driver's side)

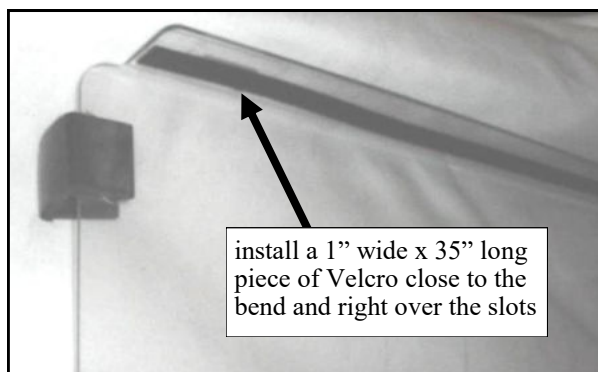

Fig. 7.1 (view taken from front of passenger's side)

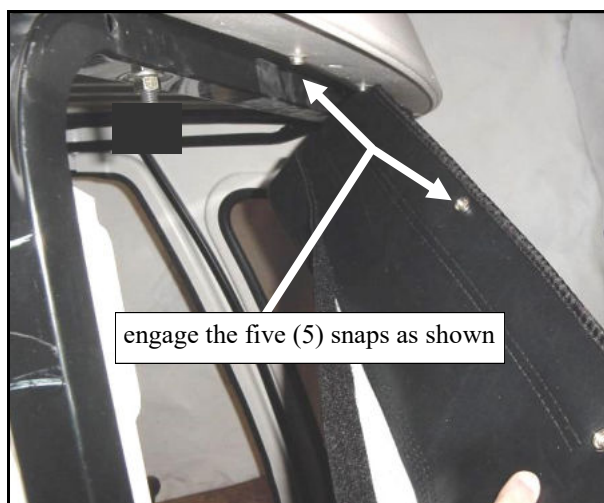

Fig. 7.2 (view taken from passenger's side)

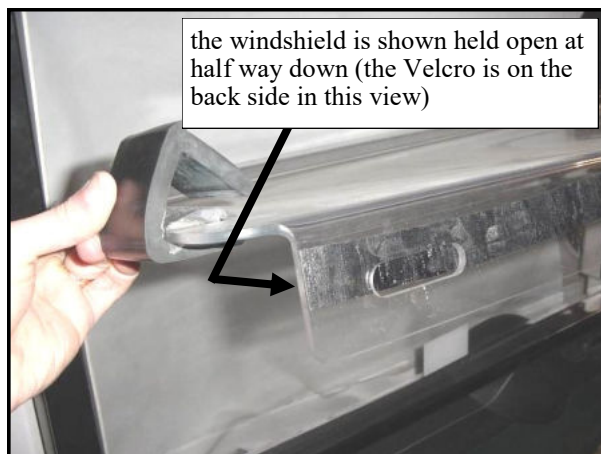

Fig. 7.1.1 (view taken from front of passenger's side)

7. FRONT DRAFT PANEL (cont'd.)

7.3 Fig. 7.3 shows the windshield in the up, closed position. The front draft panel is snapped in place and fitted around the narrow bent portion of the windshield so the velcro sections "c" and "d" are mated together (the photo shows them slightly peeled apart for illustration purposes). Velcro sections "a" and "b" are only used for storage up and out of the way when the top half of the windshield is folded down for ventilation (open). Figure 7.3.1 shows the front draft panel in storage mode.

8. COWL FILLER

8.1 Per fig. 8.1, the two bends in the lower window are shown. Attach the velcro to the inside surface as shown up against the lower, first bend. The velcro can be cut to the full width of the lower window (37-3/4") even though the first and last 1" will not be used where the cowl filler will bend inward and attach to the plastic per fig. 8.2.

8.2 Per fig. 8.2, attach a 3" long piece of velcro on the plastic where shown. Repeat for passenger's side.

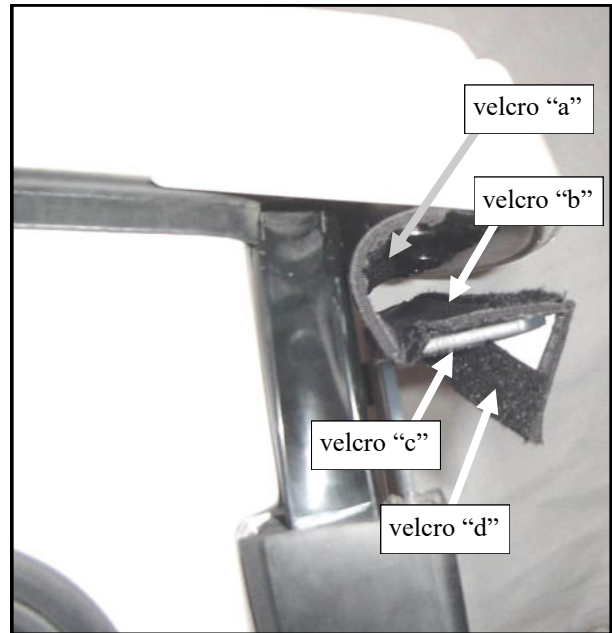

Fig. 7.3 (view taken from passenger's side)

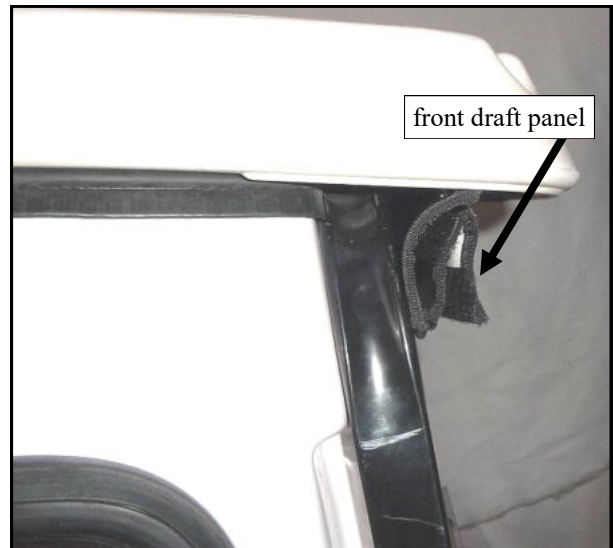

Fig. 7.3.1 (view taken from passenger's side)

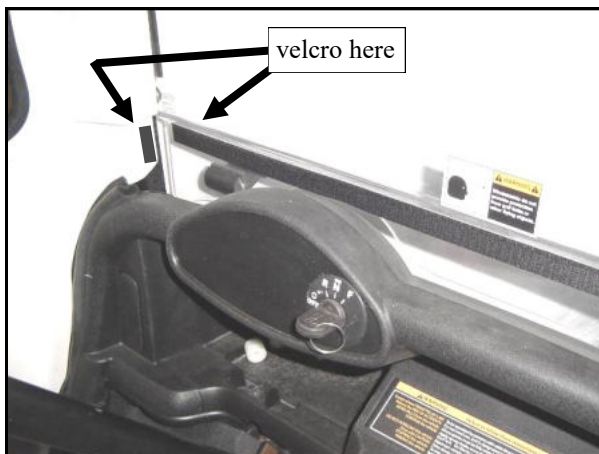

Fig. 8.2 (view taken from rear of passenger's side)

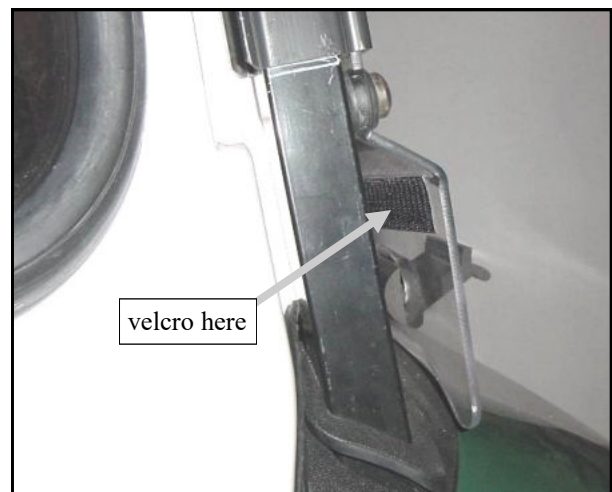

Fig. 8.1 (view taken from passenger's side)

8. COWL FILLER (cont'd.)

8.3 Per fig. 8.3, install the cowl filler to the newly installed velcro by estimating the approximate center for evenness. Peel apart and re-adjust if off center too much.

8.4 Per fig. 8.4, push the entire length of the long, loose bottom edge of the cowl filler out from under the window to seal against the hood of the vehicle. Per fig. 8.4.1, velcro may be installed on to the top outer surface of the plastic hood if desired (not required) (use installer's discretion).

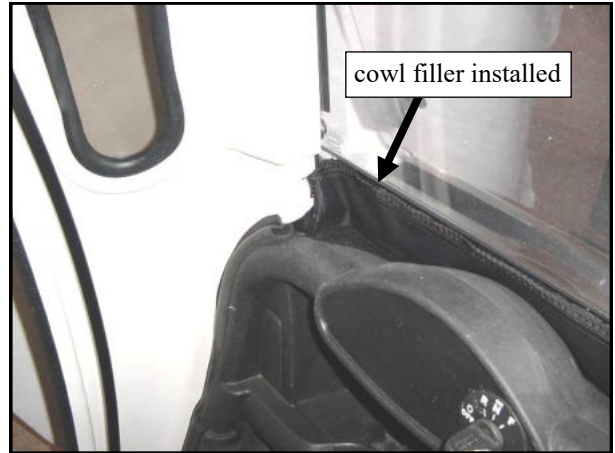

Fig. 8.3 (view taken from rear of passenger's side)

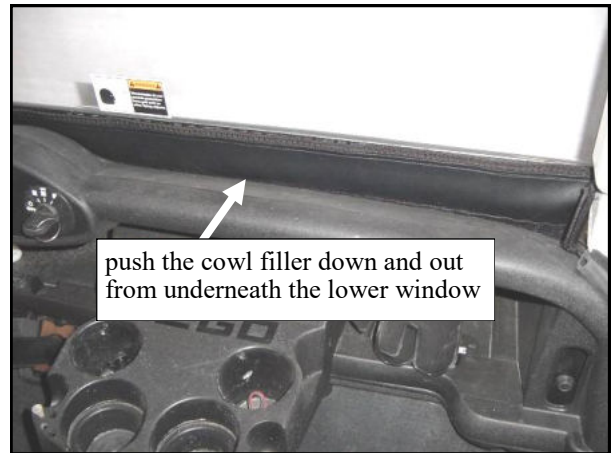

Fig. 8.4 (view taken from rear of vehicle)

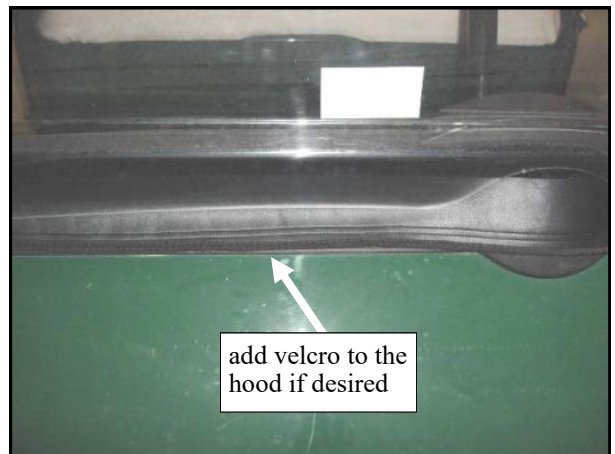

Fig. 8.4.1 (view taken from front of vehicle)

9. REAR CURTAINS

9.1 Per fig. 9.1, install two more self-tapping snaps into the back side of the plastic seat as follows: 1/2" down from the crest (corner) and 14" center to center (7" left and 7" right of center). Note: the bright, white circles represent the snaps for clarity in the photo. Note: do not over-tighten. Over-tightening may strip the plastic threads. Note: extra snaps have been provided. Discard any extras.

9.2 Per fig. 9.2, snap the lower rear curtain in place as shown and work all the loose edges down and towards the sides of the vehicle. Note: the bright, white circles represent the snaps for clarity in the photo. The bottom edge and the two sides remain loose (no velcro or snaps) and should be pulled down taught in front of the seat back support strut cover (i.e.: the rubber boot) (see figure 9.2.1).

9.3 Per fig. 9.3, install the clear, top, rear curtain by engaging the four (4) snaps per left and right sides, then the four (4) snaps up top on the roof, then lastly attaching the velcro where the two rear curtains meet just above the top of the seatback. Note: fig. 9.3 also shows the velcro roll up straps. For ventilation, unsnap four snaps per left and right side for a total of eight snaps, disengage the horizontal piece of velcro holding the two halves together, then roll the clear rear curtain up utilizing the mating velcro straps to hold it up out of the way (leave the four top snaps in the roof engaged).

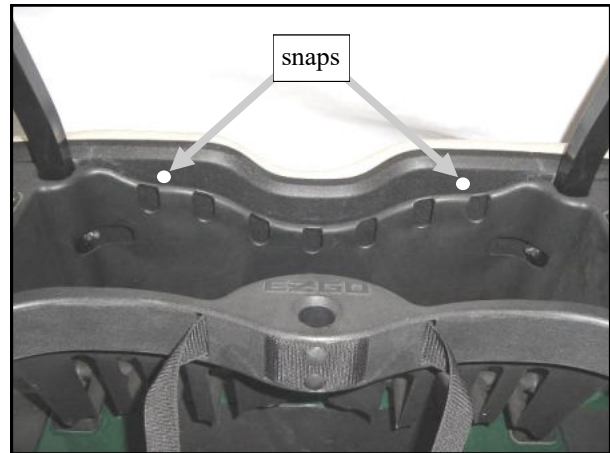

Fig. 9.1 (view taken from rear of vehicle)

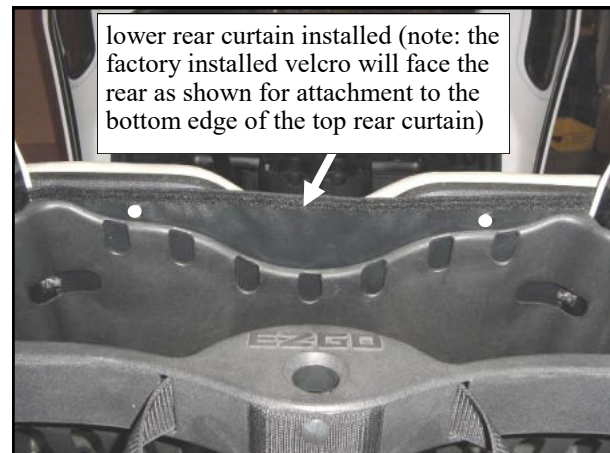

Fig. 9.2 (view taken from rear of vehicle)

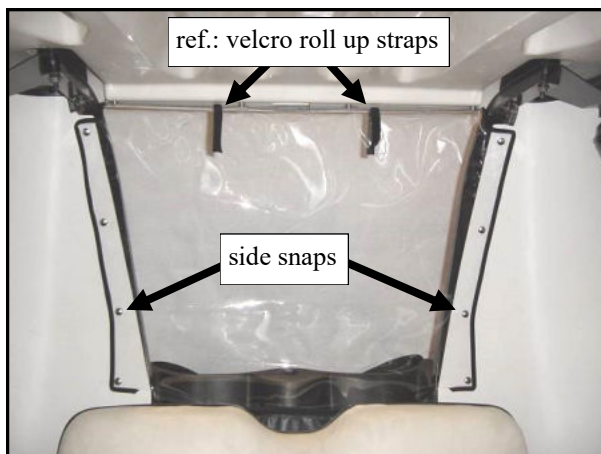

Fig. 9.3 (view from front of vehicle)

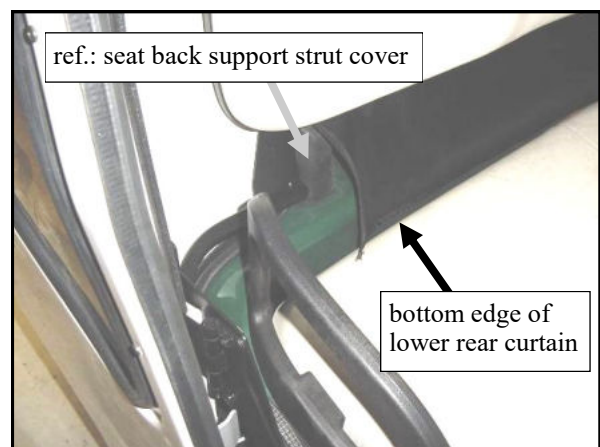

Fig. 9.2.1 (view from front of passenger's side)

10. BUNGEE CORD

10.1 Per figures 10.1 and 10.2, install one of the two p-clamps to the rearmost bolt behind the seat as shown. Orient the p-clamp so the flat section is upward. Temporarily remove the nut, place the p-clamp on to the bolt, re-install and tighten the nut. Repeat for driver's side.

10.2 Per fig. 10.2 and with the door open and towards the rear of the vehicle, stretch and connect the bungee cord to the newly installed p-clamp to keep tension on the door in the open position. Repeat for driver's side.

11. DOOR ADJUSTMENT

NOTE: If the door does not shut completely or has a gap in the front or back sealing area due to vehicle variation, the following adjustments may be required:

11.1 Per fig. 11.1, remove the sideframe end of the gas shock by releasing the metal clip and pulling the housing off the pivot ball. Loosen the two top pivot bolts. From the inside, pull the door grab handle and hold while retightening the two top pivot bolts. Reinstall the gas shock on the pivot ball.

11.2 If further adjustment of the door is required, the hinge location can be modified. Remove the seat as shown in fig. 11.2. Loosen the four hinge bolts. From the inside, pull the door grab handle and hold while retightening the four hinge bolts. Reinstall the seat.

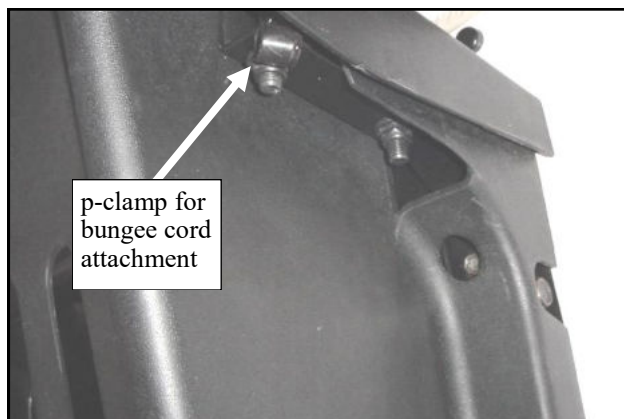

p-clamp for bungee cord attachment

Fig. 10.1 (view from rear of passenger's side)

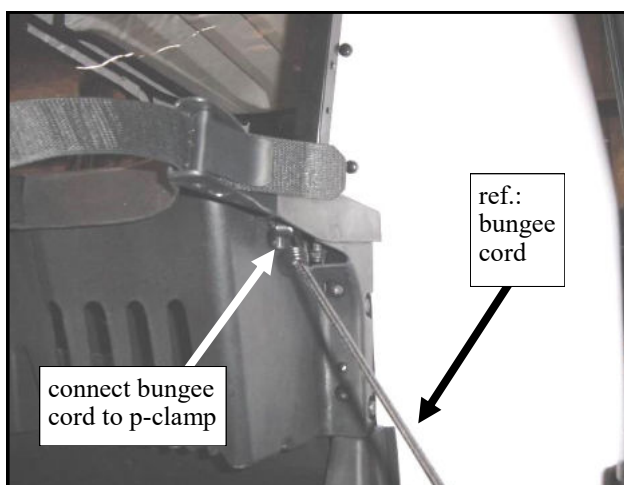

connect bungee cord to p-clamp

ref.: bungee cord

Fig. 10.2 (view from rear of passenger's side)

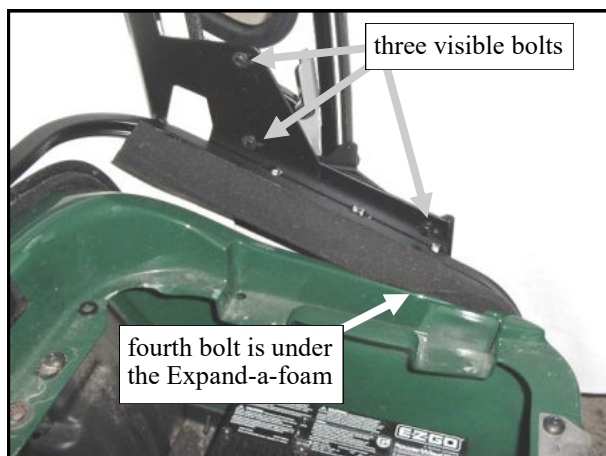

three visible bolts

fourth bolt is under the Expand-a-foam

Fig. 11.2 (view taken from passenger's side)

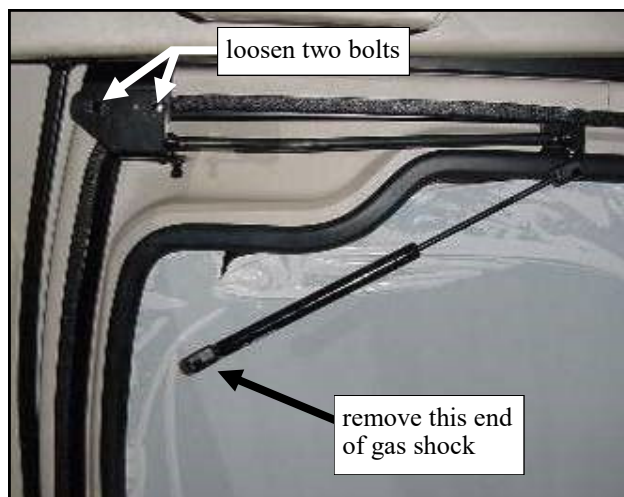

loosen two bolts

remove this end of gas shock

Fig. 11.1 (view from inside of driver's side door)

11. DOOR ADJUSTMENT (cont'd.)

11.3 If further adjustment of the door is required, loosen the two seat bolts marked "a" in fig. 11.3. Slide the rear of the side frame assembly in or out and retest the door seal. Adjusting this area can sometimes improve the seal in the back of the door.

12. FINISHING TOUCHES

12.1 Per fig. 12.1, the Expand-a-foam can be tucked in neater/tighter at the installer's discretion. Repeat for driver's side if desired.

12.2 Peel protective film from windows.

12.3 Note: extra hardware has been provided in case they get lost. Discard extras such as snaps, etc..

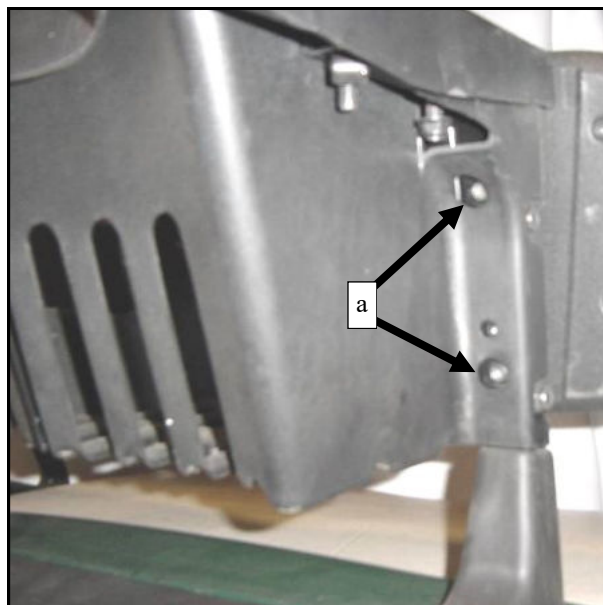

Fig. 11.3 (view taken from rear of passenger's side)

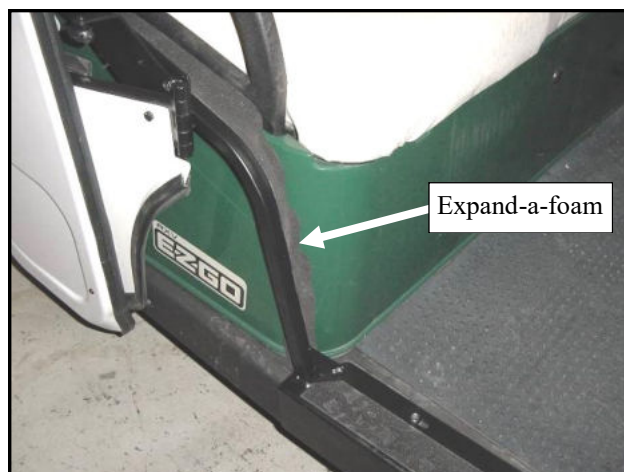

Fig. 12.1 (view from front of passenger's side)

E-Z-GO RXV

CARE AND MAINTENANCE (IMPORTANT: be sure to leave this page with the owner once installation is complete)

Check and tighten hardware after 40 hours of operation.
Periodically inspect and tighten hardware for the remainder of the unit's service life.

IMPORTANT CLEANING INFORMATION

Keep the enclosure components clean in order to prevent dust and dirt from forming an unattractive film. The life of your acrylic windows, doors, and body panels depends upon following these care procedures:

WINDOWS:

- 1) **NEVER USE** AN ALCOHOL-BASED PRODUCT FOR CLEANING. Do not use **WINDEX, GLASS PLUS, FANTASTIC**, etc. Use of these products will result in deterioration of the acrylic item.
- 2) Wash with a mild soap or detergent using your bare hands to free or dislodge any caked-on dirt or other foreign particles.
- 3) A soft, grit-free cloth, sponge, or chamois may be used but only as a means of carrying water to the windows.
- 4) The interior should be lightly dusted (NOT WIPED) with a clean soft cloth or chamois. The cloth or chamois should be kept free of grit by frequent rinsing in clean water.
- 5) Grease and oil may be removed with kerosene.
- 6) Novus I and Novus II are recommended plastic cleaners for acrylic units and can be used to remove light scratches.

DOORS AND BODY PANELS:

- 1) **NEVER USE** AN ABRASIVE DETERGENT/VEHICLE CLEANER OR A WIRE BRISTLED BRUSH. Do not use any **CITRUS BASED CLEANERS** such as orange or lemon. Use of these products will cause the plastic to become permanently damaged.
- 2) Clean the plastic enclosure surfaces thoroughly with warm soapy water and a COTTON cloth or chamois. Be sure to use mild soap, specifically a dish liquid or equivalent. Clean in a light circular motion for best results.
- 3) Use EXTRA CAUTION when cleaning the interior of the enclosure. The interior is more sensitive than the exterior because the exterior has an extra coating for U.V. stability.
- 4) Remove grease and oil with mineral spirits and a COTTON cloth or chamois.

QUESTIONS AND COMMENTS

Questions or comments regarding this enclosure should be referred to your local golf car dealer.

When calling, please have your dealer number, vehicle model, part number, and quantity available.

For service parts contact: Curtis Industries, LLC.
Phone: 1-800-343-7676 Fax: 1-800-876-9104

www.curtiscab.com
E-mail: info@curtiscab.com