



Kioti CK10 Series
Advantage Cab p/n: 1KTCKCA; Plus Cab p/n: 1KTCKPC
 Fits Tractor Models: CK2610HST, CK3510HST, CK4010HST, CK2620HST, CK3520HST, CK4020HST and SE HST models*. Compatible with KL4030 loader and KB14575L backhoe. Also fits Bobcat CT2025HST, CT2035HST, and CT2040HST.*
Compatible with FL8 loader and BH76 backhoe.
***Modifications required to fit Kioti SE and Bobcat models.**

While this cab kit was designed to fit on the vehicle(s) listed above, manufacturing tolerances and vehicle assembly may affect cab fitment. It is the responsibility of the cab installer to check all vehicle pedals and levers for full functionality and, as required, adjust the cab fitment to prevent any interference of the cab components with the travel of pedals or levers.



Advantage Cab Shown with Curtis and Artillian accessories

Available Options:

- | | |
|--|----------------------------------|
| 1. Front LED Work Lights (P/N: 9LEDW4) | 6. Side View Mirrors (P/N: 9PM5) |
| 2. Rear LED Work Lights (P/N: 9LEDW3) | 7. Rear View Mirror (P/N: 9PM3) |
| 3. Strobe Light (P/N: 9LEDS2) | 8. Rear Wiper (P/N: 9PWK85F) |
| 4. Dome light (P/N 9LEDD14) | 9. Seal Kit (P/N: 9SK10) |
| 5. Switch Panel (P/N: 9PSF1) | |

Note: Front wiper (P/N: 9PWK110) and Heater (P/N: 9PH20S62) are supplied with the cab kit.

Approximate Installation Time *
Experienced Dealer Technician – 7 Hours
Average Dealer Technician – 8 Hours
Do-It-Yourself – 10 Hours

Approximate Product Specifications
Floorboard to Roof Height: 60 inches
Weight: 303 lbs. (Advantage), 254 lbs. (Plus)
Cab Width: 51 inches

(*=Not including accessories)

Register your new product quickly online at Curtiscab.com/product-registration/



Curtis encourages all customers to register their Curtis products. However, failure to do so will not diminish right to warranty. Curtis Industries does not sell or share your information with anyone else.

Download a digital copy of your installation instructions online at Curtiscab.com/literature/



Curtis strives to continuously improve our products, technical documentation, etc. Therefore, the installation manual for this product may have been updated after your product was packaged. The latest revision of the installation manual can always be found at the website above.

The contents of this envelope are the property of the owner. Leave with the owner when installation is complete.

TABLE OF CONTENTS

WARNINGS, TIPS, & REQUIRED TOOLS.....	3
CAB INSTALLATION.....	4-15
CAB FEATURES & OPERATION.....	16
CARE AND MAINTENANCE.....	16
SERVICE PARTS	17-19
OPTIONAL ACCESSORIES	20
BOLT TORQUE SPECIFICATIONS	21-22



WARNINGS, TIPS, & REQUIRED TOOLS

Curtis cabs feature an assembly of parts designed for your vehicle which require adjustment and alignment of components to accommodate vehicle variations and provide proper weather protection. For accurate installation, proper operation, and years of satisfaction, please read and understand the installation and owner's manual fully prior to installing the cab.

From all of us at Curtis, we thank you for choosing our product.

	<h3>NOTICE</h3>
<p>Curtis Cabs, blades and general accessories add additional weight to the base vehicle. All Curtis accessory weights are listed in product brochures. Deduct the accessory's total weight from the vehicle's rated capacity and never exceed the vehicle's rated capacity including driver and passenger.</p>	

▲ WARNING Exposure to Carbon Monoxide can Cause illness, serious injury or death. Never operate vehicle if suspicious of Carbon Monoxide. Inspect exhaust system for leaks monthly. Leaks can result from loose connections, corrosion, cracks or other damage to the exhaust manifold. If leaks are found, repair or replace exhaust system. Do not use vehicle until repair or replacement is complete.

▲ WARNING	
S e r i o u s I n j u r y o r D e a t h	
	This cab enclosure does not provide protection from rollover or other accidents.
	This cab enclosure does not provide protection from flying objects including golf balls.
	This cab enclosure does not provide protection from lightning. When lightning threatens take cover and do not operate vehicle.

California Health and Safety Proposition 65 Warning: This product may contain chemicals known to the state of California to cause cancer and birth defects or other reproductive harm.

GENERAL INFORMATION BEFORE YOU START

HELPFUL HINTS:

- Refer to parts diagram found in the service parts section of this manual to help identify parts during the assembly process.
- To assist with the cab installation, leave all fasteners loose for later adjustment unless otherwise specified.
- Read and understand all instructions before beginning.
- Apply a silicone sealant to seal any minor gaps that may occur due to vehicle variations.
- Use caution to avoid damaging the factory installed threaded inserts or weld nuts. Begin the thread engagement by hand to avoid or correct potential cross threading.
- Make sure the areas where the supplied self-adhesive hook Velcro will be applied are clean and dry and at room temperature for best adhesion.
- Before installing parts with factory installed rubber, make sure the rubber is fully installed onto the parts for proper fit and sealing.
- Plastic washers have been supplied to provide a weather seal under the heads of some exterior bolts. The plastic washer should be installed under each bolt head directly against the outside cab surface. Care should be taken not to over tighten the fasteners and damage the plastic washer.

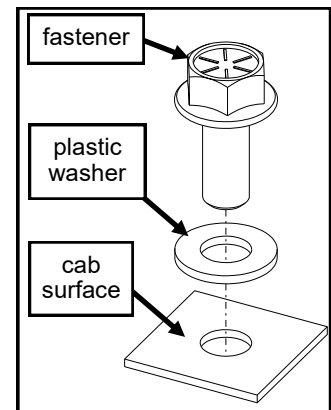

TOOLS REQUIRED:

- Set of Standard and Metric Sockets (3/8" Drive)
- 3/8" Drive Ratchet and Long Drive Extension
- Set of Standard and Metric Open-End Wrenches
- Set of Standard and Metric Allen Wrenches
- #2 and #3 Phillips Head Screwdrivers
- Torque Wrench
- Awl
- Automotive Brake Cleaner
- Impact Gun
- Drill/Driver
- 3/8" and 7/32" Drill Bits
- 2" hole saw (SE Only)
- Sawzall (SE Only)
- #2 and #3 Phillips Head Bit
- Utility Knife
- Pair of Scissors
- Shears
- Grease
- Silicone Sealant

CAB INSTALLATION

STEP 1: (VEHICLE PREP, ALL)

- 1.1 Disconnect the battery, negative first, and then positive.
- 1.2 See fig. 1.2. If equipped, remove and disconnect turn signal lights from the fenders. If the turn signal lights are installed on the ROPS, they may remain in place at this time.
- 1.3 If equipped, pull up the sides of the floorboard mat. If installing a seal kit, the mat should be removed from the tractor and set aside.
- 1.4 See fig. 1.4. Remove the 2 large plugs from the left and right side of the tractor floorboard.
- 1.5 Skip to next step if installing on SE model. Remove the step from the left side of the tractor floorboard and retain the step and hardware.
- 1.6 If equipped, lift the SMV sign from its holder and save.

NOTE: If a seal kit will be installed with this cab, do so now. Refer to the seal kit installation instructions.

TIP: The cab can be installed with the ROPS up, but folding it for certain steps may make the installation easier.



Fig. 1.2 (Turn Signal Lights)

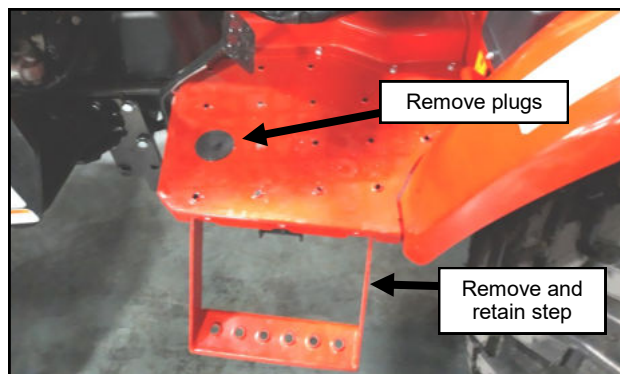

Fig. 1.4 (Tractor Floorboard)

STEP 1A: (VEHICLE PREP, BOBCAT)

- 1A.1 Relocate loader hydraulic quick connects forward to make clearance for the cab by drilling new holes in the mounting bracket as shown in figure 1A.1.
- 1A.2 If necessary, drill a new 1-1/8" dia. hole in cowl to route heater hoses around loader hydraulic lines. Locate hole directly above the existing inboard hole as shown in figure 1A.2. Plug - cover outboard hole not used.



Fig. 1A.1 (Hydraulic Mount)

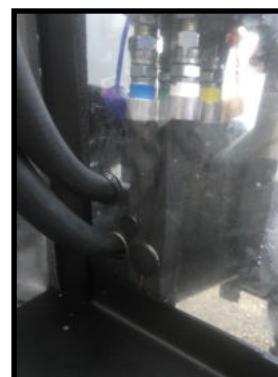

Fig. 1A.2 (Heater hose)

CAB INSTALLATION

STEP 2: (MOUNTING BRACKETS, SE MODELS)

- 2.1 Reference fig. 2.1. Use bandsaw, Sawzall, or similar to cut foot off of floorboard mount. Repeat for opposite side.

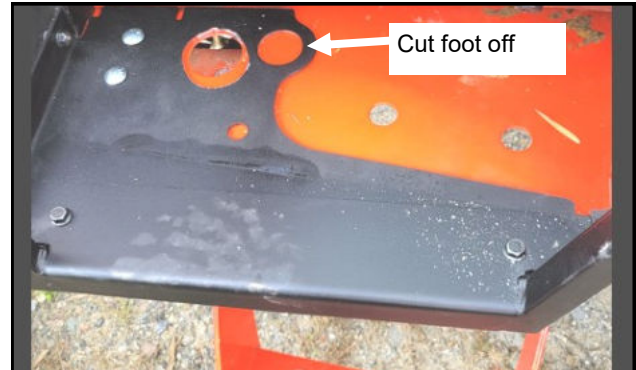

Fig. 2.1 (Modify floorboard mounts)

STEP 2A: (MOUNTING BRACKETS NON SE MODELS)

- 2A.1 Remove, and save for reuse, the OEM nut and lock washer from the large hole in the left tractor floorboard where the plug was removed in step 1.4, using an impact gun. Place the tube on the underside of the left cab floorboard mount into the hole, over the stud, and secure with the same OEM nut and lock washer. See Figure 2.1.

NOTE: Unless otherwise specified, tighten the bolts just snug enough to secure the parts. Bolts will be tightened at a later step once the rest of the cab has been fully assembled.

- 2A.2 Repeat step 2A.1 for the right side.

- 2A.3 Per figure 2A.3, install the step adapter bracket in place of the step under the left floorboard, using the hardware that was removed and align to the holes in the cab floorboard mount.

Attach the tractor step to the adapter with new hardware. Tighten all hardware for the step.

<u>Hardware Used</u>	<u>Qty</u>
5/16-18 X 3/4" lg. Hex Head Screws	3
5/16-18 Hex Nuts	3

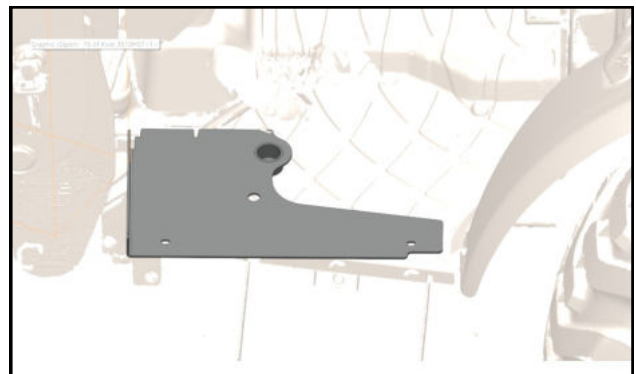

Fig. 2A.1 (Floorboard Mounts)

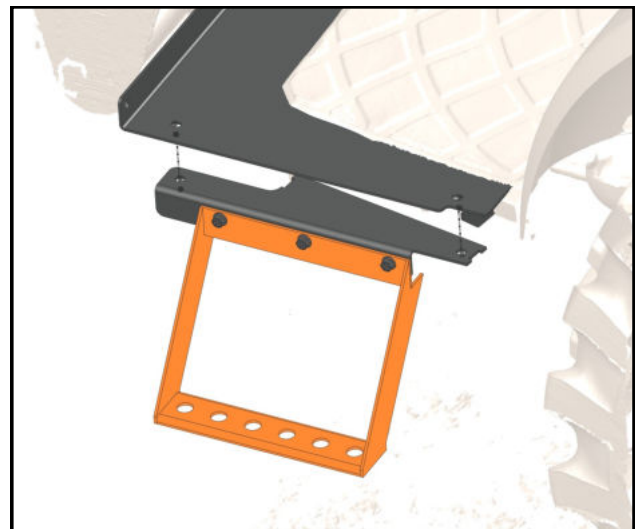

Fig. 2A.3 (Step Adapter)

CAB INSTALLATION

STEP 3: (SIDE FRAME / REAR LEG)

- 3.1 Remove the left door from the left side frame by unlatching at the handle and lifting the door off the hinge pins. Remove the brass washer from each pin (two per door) and set aside for later use.

NOTE: If the washer can't be found, check if it stuck to the door hinge or fell on the floor.

- 3.2 Attach the left ROPS mount to the left rear leg. See figure 3.2

<u>Hardware Used</u>	<u>Qty</u>
5/16-18 X 3/4" lg. Hex Head Screws	2
5/16-18 Hex Nuts	2

- 3.3 Attach the left rear leg, along with the ROPS mount and signal light bracket, to the left side frame as shown in figure 3.3. Align the top and outside of the rear leg to the side frame and tighten hardware.

NOTE: The signal light bracket may be discarded if the tractor turn signal light is attached to the ROPS instead of the fender.

<u>Hardware Used</u>	<u>Qty</u>
5/16-18 X 3/4" lg. Hex Head Screws	6

- 3.4 Cut the supplied length of 1 inch round bulb rubber approximately in half.
- 3.5 Per figure 3.5, attach the bulb rubber to the frame/rear leg assembly, starting at the front. Trim the excess rubber at the edge of the rear leg.
- 3.6 Repeat steps 3.1 through 3.3 and step 3.5 for the right side frame, rear leg, and ROPS mount.

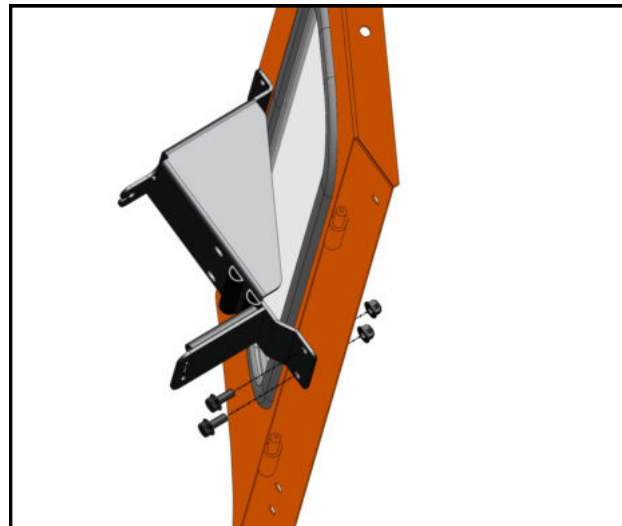

Fig. 3.2 (ROPS Mount to Rear Legs)

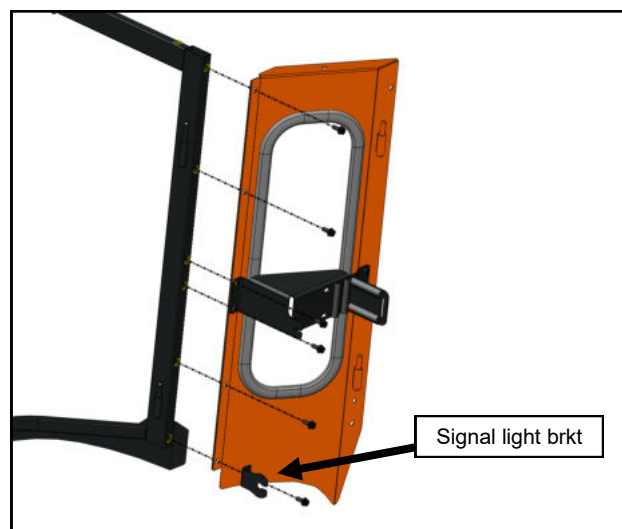
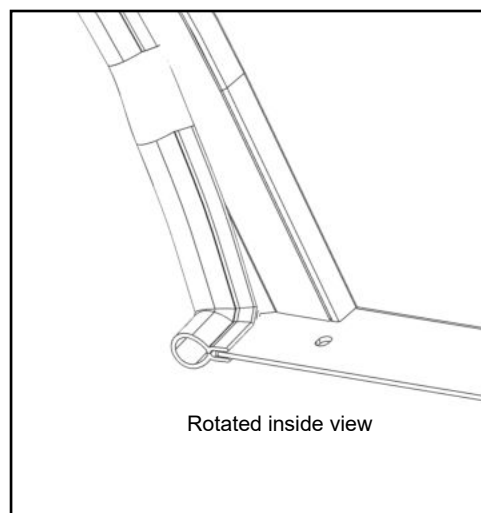

Fig. 3.2 (Rear Legs to Side Frames)



Rotated inside view

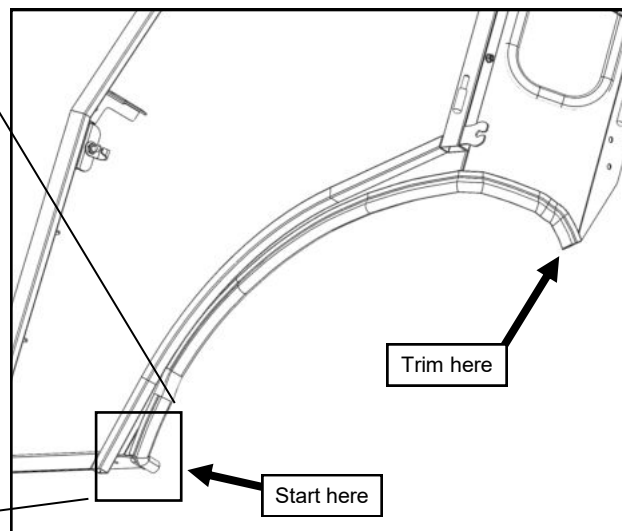

Fig. 3.5 (Frame Bulb Rubber)

CAB INSTALLATION

STEP 4: (SIDE FRAMES)

4.1 SE models only. Reference figure 4.1. Bolt the left mount to the left mounting bracket using the hardware listed in step 4.2. Position the side frame mount assembly as shown in figure 4.2. Use the plug in the floormat to mark where the mount needs to be drilled or cut. Remove and drill or cut. Reposition, check under floorboard and find appropriate place to drill mount and tractor floorboard for 2 button head mounting bolts, nuts and washers, not included. 5/16-18 recommended.

4.2 Place the left side frame / rear leg assembly on top of the floorboard mount and fender with the ROPS mount flange to the inside of the ROPS. See figure 4.2. Secure the side frame to the floorboard mount with two 1" long bolts and nuts. Secure the back of the rear leg to the lower rear bracket with two 3/4" long bolts and nuts.

Hardware Used

	Qty
5/16-18 X 3/4" lg. Hex Head Screws	2
5/16-18 X 1" Hex Head Screws	2
5/16-18 Hex Nuts	4

4.3 See fig. 4.3. Hook the ROPS bracket over the back of the ROPS mount, then bolt the front of the bracket to the mount with two bolts and nuts.

Hardware Used

	Qty
5/16-18 X 1" lg. Hex Head Screws	2
5/16-18 Hex Nuts	2

4.4 Use all 3/4" long bolts in step 4.2 while repeating steps 4.2 and 4.3 for the right side frame.

4.5 Per Figure 4.5, attach the lower rear bracket to the tabs at the top of the fuel tank at the rear of the tractor.

Hardware Used

	Qty
5/16-18 X 3/4" lg. Hex Head Screws	2
5/16-18 Hex Nuts	

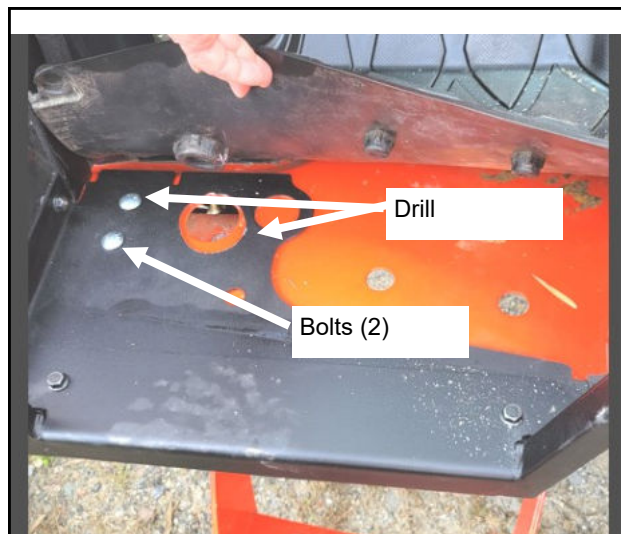

Fig. 4.1 (Modify floorboard mounts)

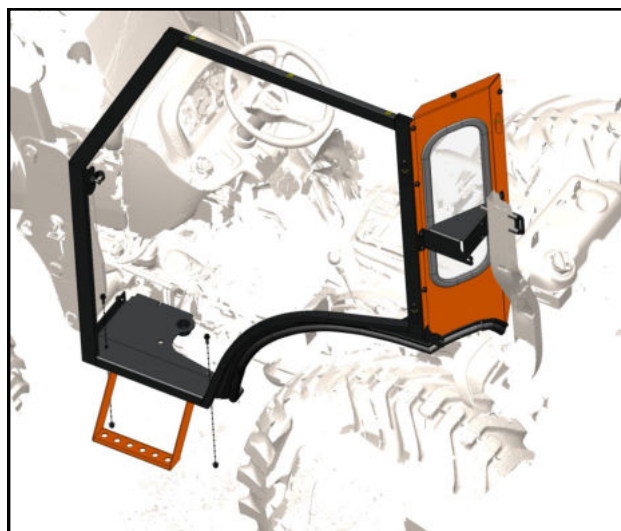

Fig. 4.2 (Side Frame)

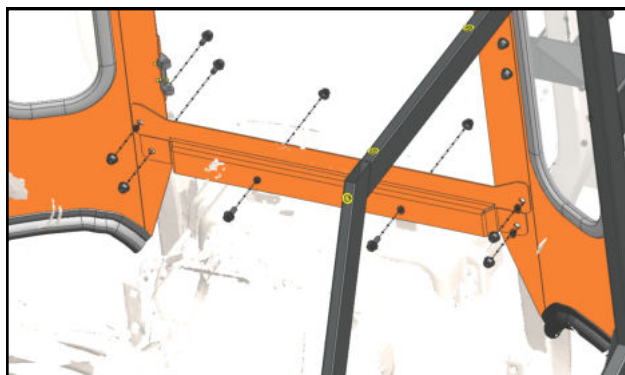

Fig. 4.5 (Lower Rear Bracket)

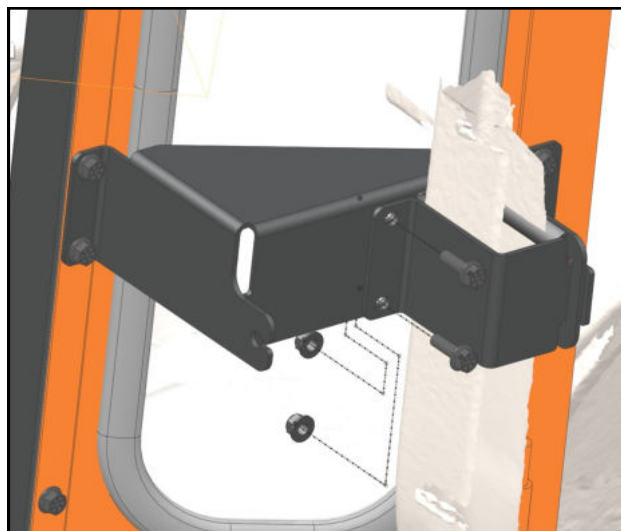

Fig. 4.3 (ROPS Bracket)

CAB INSTALLATION

STEP 5: (COWL)

- 5.1 Install the provided small rubber grommet into the lowest hole in the right side of the cowl. Install the 2 larger grommets in the remaining 2 holes. With assistance, slide the cowl over the top of the hood and engine side covers using **CAUTION** not to scratch the plastic components. Secure the cowl to the side frames with hardware listed below. Use 1 inch long bolts at the corners of the cowl and plastic washers under the heads of any bolts in contact with the plastic parts of the cowl. See Figure 5.1.

<u>Hardware Used</u>	<u>Qty</u>
5/16-18 x 3/4" lg. Hex Head Screws	10
5/16-18 x 1" lg. Hex Head Screws	4
5/16" Plastic Washers	8
5/16-18 Hex Nuts	14

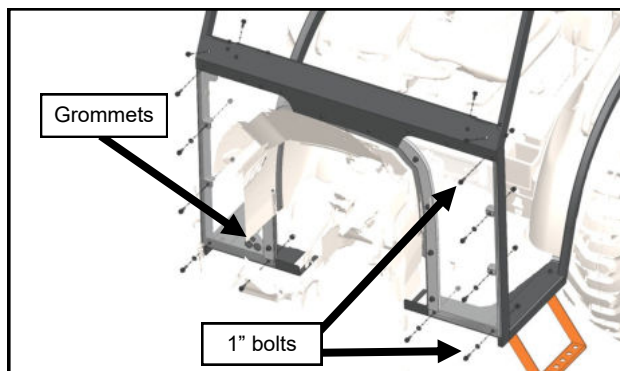

Fig. 5.1 (Cowl)

STEP 6: (WINDSHIELD SUPPORT)

- 6.1 Install the windshield support onto the side frames, bolting to the threaded inserts in the front of the frames. See Figure 6.1. Align the sides of the cowl with the edges of the side frame and tighten these bolts at this time.

<u>Hardware Used</u>	<u>Qty</u>
5/16-18 x 3/4" lg. Hex Head Screws	2



Fig. 6.1 (Windshield Support)

STEP 7: (WINDSHIELD)

- 7.1 With assistance, set the windshield up to the A-pillars and secure it to the roof using the hinge spacers and hardware. See Figure 7.1.

<u>Hardware Used</u>	<u>Qty</u>
5/16-18 x 1-1/2" lg. Flat Head Screws	4
5/16-18 Hex Nuts	4

- 7.2 Secure the windshield latches to the A-pillars. With the latches open, tighten latch hardware. See Figure 7.2

<u>Hardware Used</u>	<u>Qty</u>
1/4-20 x 3/4" lg. Hex Head Screws	4
1/4-20 Hex Nuts	4

- 7.3 Close the windshield while lifting up on the bottom edge. Tighten hinge hardware. **Caution: The windshield hinges are plastic components. Do not overtighten the flat head screws. Torque to 7 ft.-lbs. max.**
- 7.4 Ensure the windshield latches function properly and the windshield pivots open.
- 7.5 Remove the over-tightening caution decal from the top of the windshield.

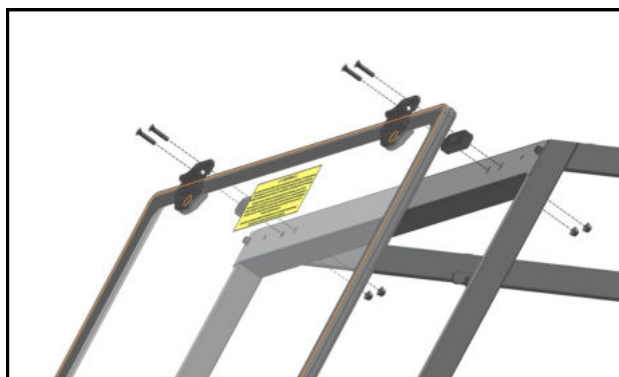

Fig. 7.1 (Windshield Hinges)

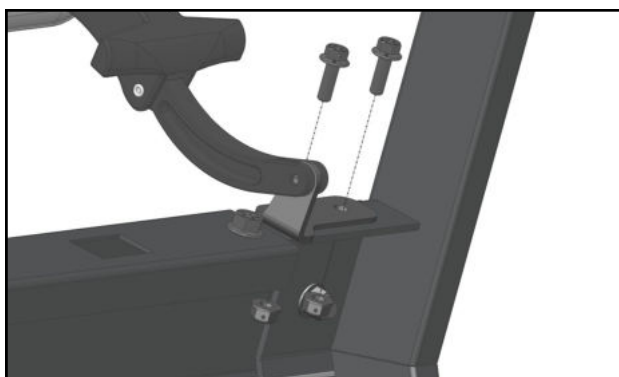

Fig. 7.2 (Windshield Latches)

CAB INSTALLATION

STEP 8: (ROOF)

- 8.1** Prep the roof for installation by piercing the headliner below the top mounting slots. Use a screwdriver to poke holes through the headliner from the headliner side up through the hole in the roof to avoid having the headliner pull away from its glued surface
- 8.2** With assistance, set the roof on top of the Side Frames, Windshield Support, and Rear Legs. See Figure 8.2. Loosely secure with sealing washers on the ten (10) screws through the top of the roof, and no sealing washers on the two (2) screws through the back of the Rear Legs.

<u>Hardware Used</u>	<u>Qty</u>
5/16-18 x 3/4" lg. Hex Head Screws	12
5/16" Plastic Washers	10
5/16-18 Hex Nuts	6

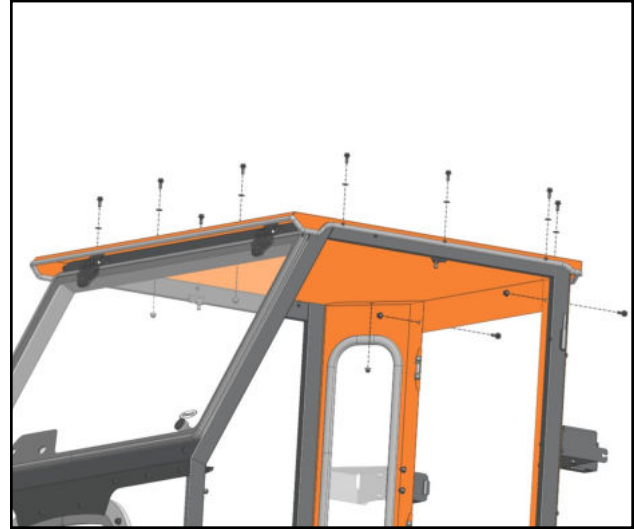

Fig. 8.2 (Roof)

STEP 9: (REAR WINDOW OR CURTAIN)

Glass Rear Window (Cabs with steel doors only)

- 9.1** Grease the hinge pins for the rear window, and slide on greased brass washers (one washer per pin). See Figure 9.1.
- 9.2** Hang the rear window on the hinges.
- 9.3** Connect the window latches to the right rear leg by depressing the tabs on the latch and inserting into the receivers mounted on the rear leg. Close and check the alignment of the window. If off, check measurements and re-align the rear legs. Tighten the hinge hardware to 7 ft-lbs. Verify smooth operation of the latches.

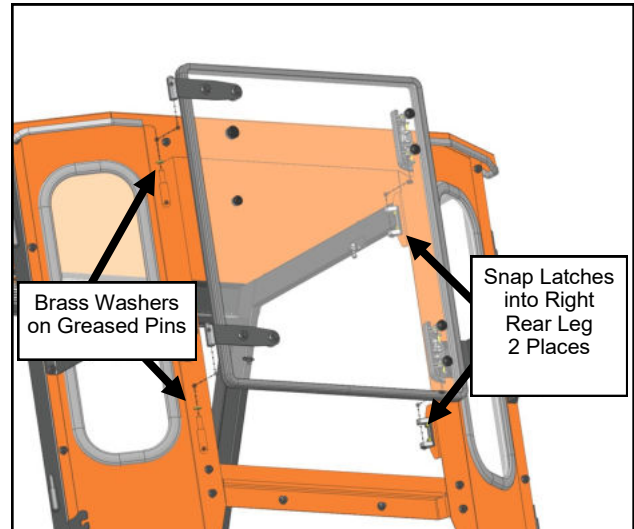

Fig. 9.1 (Rear Window)

Vinyl Upper Rear Curtain (Cabs with vinyl doors only)

- 9.4** Pre-install the supplied Velcro hook to the sewn-in Velcro loop on the upper three sides of the upper rear curtain. Leave the release tape on until the filler is in place. See fig. 9.4.
- 9.5** Apply a strip of Velcro hook to the outside face of the lower rear bracket, aligned to the top edge.
- 9.6** Align the top of the curtain to the top inside rear corner of the roof, and the sides to the inside corners of the rear legs. Remove the release tape a little at a time and stick the filler down as you work your way around.

NOTE: The vinyl will stretch around the flanges and latch mounts inside the rear of the cab. Make sure the Velcro is attached firmly to the surfaces of the cab.

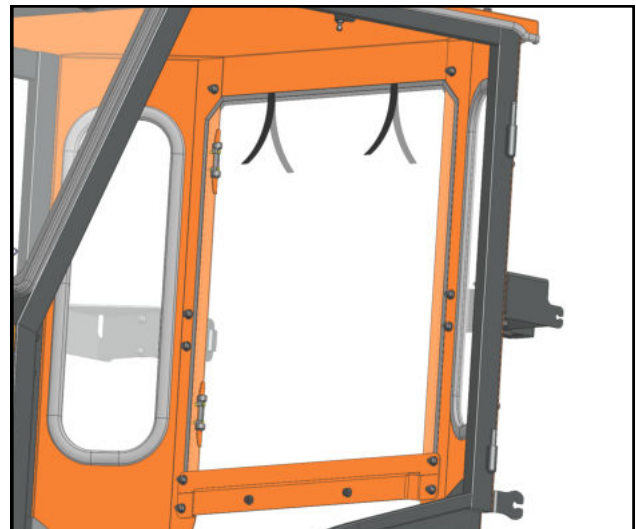

Fig. 9.4 (Upper Rear Curtain)

CAB INSTALLATION

STEP 10: (TIGHTEN HARDWARE)

10.1 Tighten all hardware at this time, using the torque values given below. Verify alignment measurements after the cab is tight.

For 5/16" bolts that use plastic washers, use only 12.5 ft.-lbs.

For 5/16" bolts that thread into factory installed threaded inserts in the A-Pillars, use 20 ft.-lbs.

For the remaining 5/16" bolts (the vast majority on the cab) that thread into hex nuts, use 28 ft.-lbs.

For all other bolt sizes (3/8", 1/4", etc.), no specific torque values are required. Tighten to a reasonable feel.

TIP: If the cowl bows out between bolts loosen and re-tighten starting with the top bolt and pushing the cowl flat while working your way down.

STEP 11: (WINDSHIELD WIPER MOTOR)

11.1 Mount the wiper motor to the windshield. See Figure 11.1. Make sure the wires are above the wiper motor shaft to prevent pinching when the windshield moves.

NOTE: Do not install the wiper arm and blade at this time. Once the motor has been wired, it can be turned on and off to ensure that the wiper arm will be parked correctly later.

11.2 Re-check the windshield pop-out function. The wiper motor should easily clear the cowl, but if not, loosen the windshield hinges and raise the windshield to gain clearance.

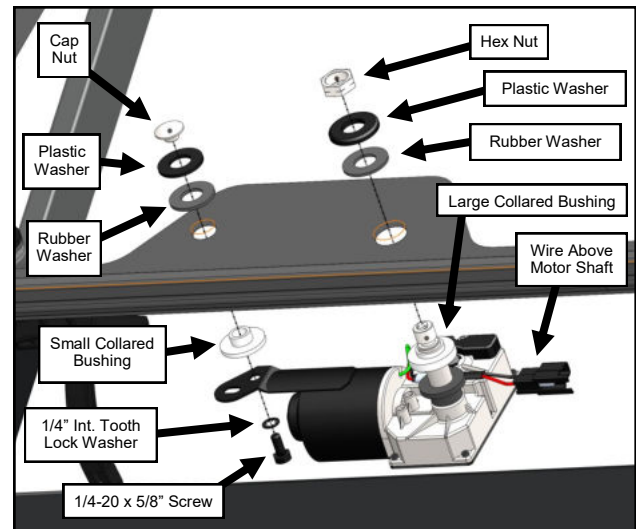

Fig. 11.1 (Wiper Motor)

STEP 12: (HEATER)

12.1 Attach the heater bracket to the right A-Pillar. See Figure 12.1. Tighten hardware.

Hardware Used

5/16-18 x 1-1/2" lg. Hex Head Screws

Qty
2

12.2 Attach the heater to the heater bracket using the screws already installed on the side of the heater. See Figure 12.1. Tighten hardware.

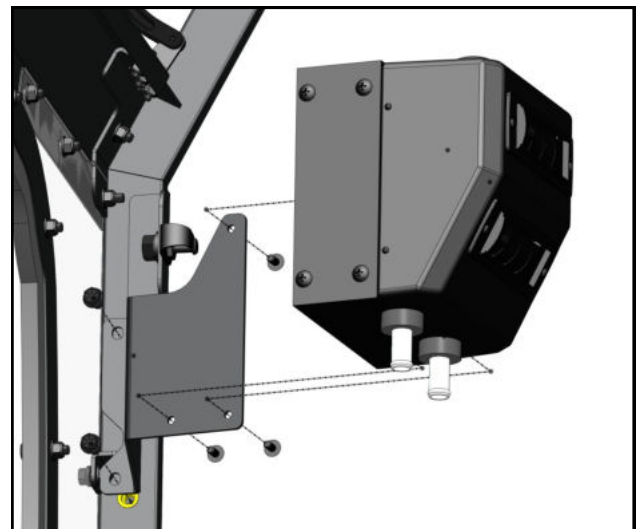

Fig. 12.1 (Heater)

CAB INSTALLATION

STEP 13: (CAB WIRING)

- 13.1** Route the power wire harness behind the heater bracket along the right side frame and connect the harness to the wiper motor.
- 13.2** Push the switch connector up through the rectangular hole in the cowl, connect to the switch and snap in the heater switch. The “off” position for this switch is in the middle, with low speed one way and high speed the other way. The switch may be installed in either direction, and can be removed and rotated 180° later if desired.
- 13.3** Open the windshield and secure the wiring harness to the cowl using a cable clamp, through the hole in the cowl. Verify the wiper harness routing allows the windshield to be opened and closed without the harness getting pinched under the windshield. See figure 13.3.

<u>Hardware Used</u>	<u>Qty</u>
3/8" Cable Clamp	1
#10-32 x 5/8" Ig. Pan Head Screw	1
#10-32 Hex Nut	1

- 13.4** See fig. 13.4. Connect the heater bullet connectors to the wiring harness. Route the wires to the right along the cowl and side frame. Route the wire down along the frame and install another clamp at the corner of the frame and floorboard. Cover the exposed wires behind the heater with 1/2" split loom provided.

<u>Hardware Used</u>	<u>Qty</u>
3/8" Cable Clamps	2
#10-32 x 1/2" Ig. Pan Head Screws	2

- 13.5** Feed the wire harness through the small grommet in the cowl. Pull any slack through the grommet to the outside of the cab.
- 13.6** Outside the cab, run the power harness into the engine bay and toward the battery. Be mindful and avoid pinch points and hot surfaces.
- 13.7** Locate the fuse harness (WH-GF). Make certain the fuse is installed in the fuse holder and connect the ring terminal on the fuse harness to the bolt on the positive battery terminal. See Figure 13.7.
- 13.8** Connect the black wire of the power harness to the bolt on the negative battery terminal. See Figure 13.7.
- 13.9** Connect the bullet terminals of the power harness and the fuse wiring harness. Coil the slack in the power harness over the battery and secure with a wire tie. See Figure 13.9. Double check that the wires are not pinched or near sharp or hot surfaces.
- NOTE: At the installer's discretion, wiring for accessories may also be installed at this time.
- 13.10** Secure wires (with wire ties provided) away from any hot or moving engine components where it could melt or be pinched.

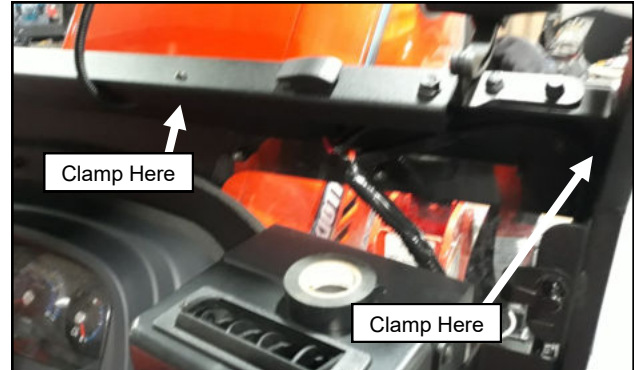

Fig. 13.3 (Wiring at Cowl)



Fig. 13.4 (Wiring at Floorboard)



Fig. 13.7 (Battery Connection)



Fig. 13.9 (Coil Wires Behind Battery)

CAB INSTALLATION

STEP 14: (HEATER PLUMBING)

CAUTION * To avoid injury caused by hot engine coolant, make sure the engine is completely cooled down before beginning plumbing of auxiliary heater.

- 14.1 Open the hood and drain the engine coolant into a clean container so that it may be reused.
- 14.2 See Figure 14.2A (CK2610) and 14.2B (other models). For the supply line for the heater, remove the plug from the thermostat housing. Install the 1/2" NPT nipple into the thermostat housing using Teflon tape (not provided).
- 14.3 For the return line from the heater, cut the lower radiator hose in the location shown. See Figure 14.3. Install the enclosed T-fitting with large hose clamps provided. **NOTE:** Spray the inside of the cut hose and the fitting with brake cleaner to ease installation.
- 14.4 **TIP: Put some liquid soap on the ends of the heater hoses to ease installation through grommets.** Feed one end of the supplied hose through one of the large grommets to the inside of the cab, connect to the heater, with 1" hose clamps. See Figure 14.4.
- 14.5 Ref. figures 14.5A and B. Route the hose along the engine bay, away from any moving parts, sharp edges, or sources of heat. Run along the bottom of the radiator keeping clear of the fan and fan belts. Cut to length and connect to the return line tee. Use the remaining hose to connect to the other heater port and the nipple installed on the thermostat housing. This is the supply line.
- 14.6 Splice into the heater supply line and install the in-line shut-off valve. See figure 14.5. **NOTE:** The in-line shut-off valve quickly converts the heater into a summer time blower by preventing hot water from flowing to the heater core.
- 14.7 Make sure no wires or hoses are pinched or interfere with any moving parts, pedals on the tractor, or contact hot engine components. Secure with wire ties provided.
- 14.8 Re-connect the battery.
- 14.9 Refill the cooling system. Start the tractor and inspect coolant system for leaks.
- 14.10 With the tractor running, check the heater hoses and make sure they get warm. If not, remove the heater from its mount and let hang from the hoses as low as possible. If the heater and hoses still do not get warm, temporarily put a clamp on the upper radiator hose to force coolant through the heater. **Warning:** To avoid engine damage, remove the clamp as soon as heater gets warm. Reattach heater to the bracket. Once complete, let the engine cool, check the coolant level, and top off coolant if required.

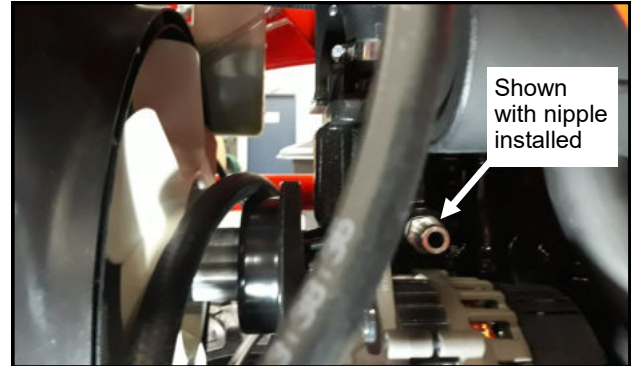

Fig. 14.2A (Remove Plug from Engine) CK2610

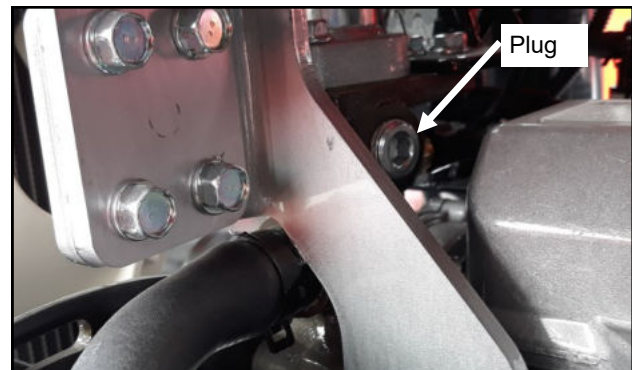

Fig. 14.2B (Remove Plug from Engine) CK3510, CK4010

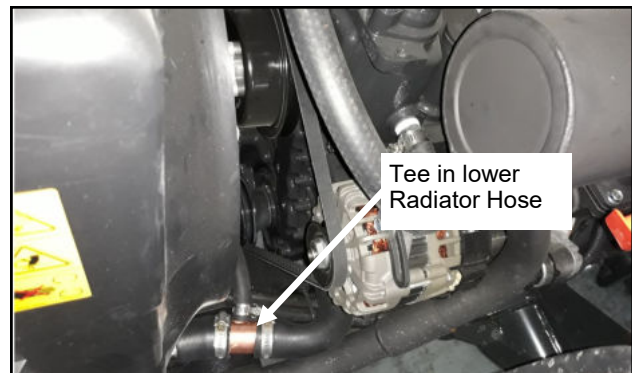

Fig. 14.3 (Lower Radiator Hose)

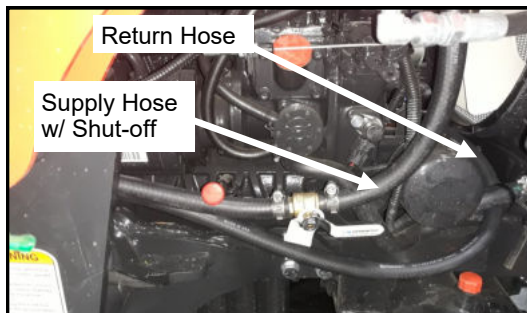

Fig. 14.5A (Return Hose Routing)

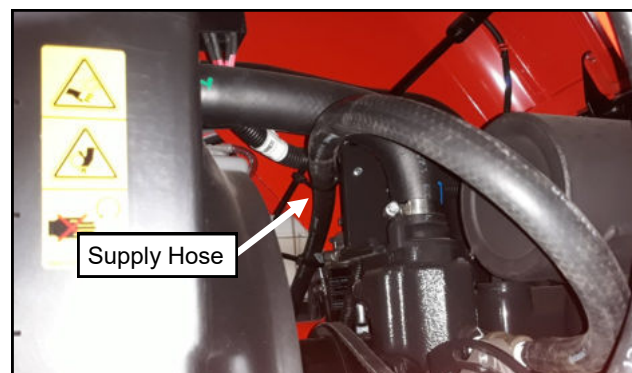

Fig. 14.5B (Supply Hose Routing)

CAB INSTALLATION

STEP 15: (FINISH WIPER)

- 15.1 Turn on the wiper motor briefly, then turn back off. This will make sure the motor shaft is in the correct parked position.
- 15.2 Pre-assemble the wiper arm and wiper blade.
- 15.3 Install the wiper arm onto the wiper motor so that the wiper is horizontal. See Figure 15.3. Tighten the Allen Screws.

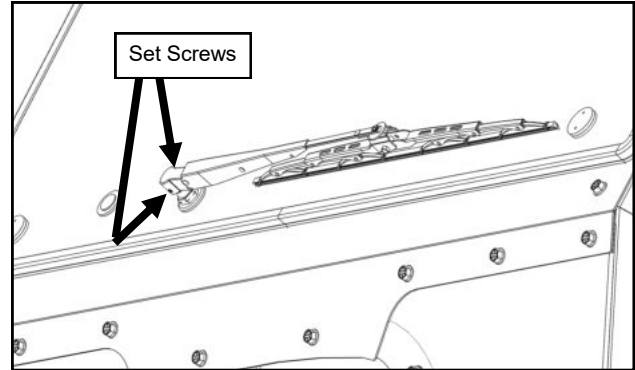

Fig. 15.3 (Wiper Arm and Blade)

STEP 16: (UNDER SEAT FILLER)

Note: Make sure the areas where the supplied Velcro will be applied are clean, dry, and at room temperature for best adhesion.

- 16.1 See fig. 16.1. Remove the large knobs from the levers to either side of the seat (one Phillip's screw each), then remove both plastic shrouds for the levers from beside the seat, (4 screws each, 10mm socket). Retain all hardware.
- 16.2 Remove the seat from the tractor and set aside (2 bolts at front, 2 nuts at rear, 12mm wrench). Retain hardware.
- 16.3 Pre-install the supplied Velcro to the under seat filler. Leave the release tape on until the filler is in place.
- 16.4 Place the slots of the under seat filler over the levers on the left, then work toward the right and up the back.
- Remove the seat wire from its clip and push the connector through the slot in the under seat filler.
- Align the holes in the filler to the studs and holes for the seat, then align the other slots and holes to the levers and the mounting points for the shrouds.
- TIP:** Bolts for the shrouds and seat can be used to keep the filler aligned until the filler is secured.
- 16.5 Remove the release tape a little at a time and stick the filler down as you work your way around. See Figures 16.1 and 16.5.



Fig. 16.1 (Install Under Seat Filler)



Fig. 16.5 (Install Under Seat Filler)

STEP 17: (FRONT FILLER)

- 17.1 Pre-install the supplied Velcro to the front filler. Leave the release tape on until the filler is in place.
- 17.2 Adhere the left side of the filler to the inner side of the left of the cowl, then below the cowl via the slot at the front of the floorboard mount. See Figure 17.2.
- Route the left of the filler below the floorboard mount then back above thru the second slot in the floorboard mount. Adhere the corner of the filler to the left of the clutch pedal.
- Work the filler along the tractor floorboard and bottom of the instrument panel, working toward the right side.
- 17.3 Remove the release tape a little at a time and stick the filler down as you work your way around. Adhere the right side of the filler under then over the right side



Fig. 17.2 (Install Front Filler)

CAB INSTALLATION

STEP 18: (DOORS)

NOTE: Steel doors are shown. Installation and adjustment steps are the same for steel or vinyl side doors.

- 18.1** Reinstall the brass washers that were removed in Step 3 (one washer per pin) onto the hinge pins on the left side and then apply grease to the pins.
- 18.2** Hang the left door on the hinges and check the door latch. You should be able to hear 2 clicks as you slowly engage the latch on the pin. If not, proceed to adjust the door per the following steps.
- 18.3** Loosen the door hinges to allow for adjustment. While lifting up and forward on the door handle, line up the door latch with the striker pin and carefully attempt to latch. If the latch is too far forward or back to latch on the pin, adjust as shown, then retighten and latch. See figures 18.3a and b.
- 18.4** Stand back and examine the alignment of the door with the roof and the A-pillar. You can adjust this by moving the striker pin up or down as shown in fig. 18.4 to help with alignment. *TIP: In the final step, the front of the door will drop a small amount the first time you open it. Set the front of the door a little bit higher so it aligns properly.* Adjust as necessary until you are happy with the alignment. Have an assistant sit inside the cab and once more carefully close the door like you did in step 18.2. Work with the assistant and tighten the hinge bolts.
- 18.5** Open the door and check for smooth operation of the latch. As noted in step 18.4, the door will likely drop a little bit at the front and the striker pin will need to be adjusted down accordingly. Also make sure the door seal is making contact along the perimeter of the door and the latch clicks twice when closing. If necessary, adjust the striker in or out to achieve this. See Fig. 27.3.
- 18.6** See fig. 18.6. With the door open, attach a gas strut to the ball studs on the side frame and door. Make sure the quick release end is on the side frame so that the gas strut stays with the door if removed for ventilation.
- 18.7** Repeat steps 18.1 through 18.7 for the right door.

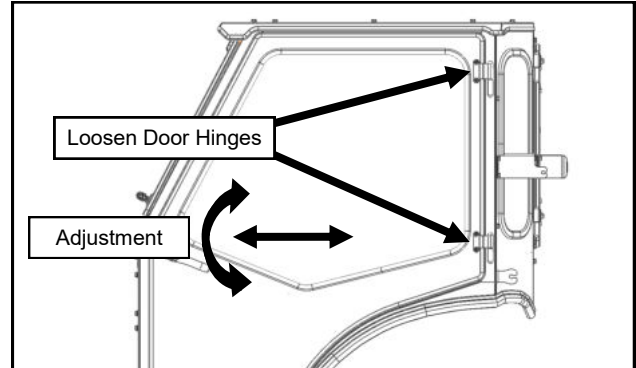

Fig. 18.3a (Door Hinge Adjustment)

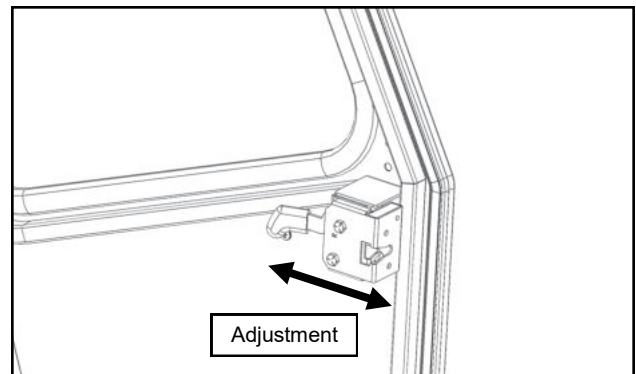

Fig. 18.3b (Door Latch Adjustment)

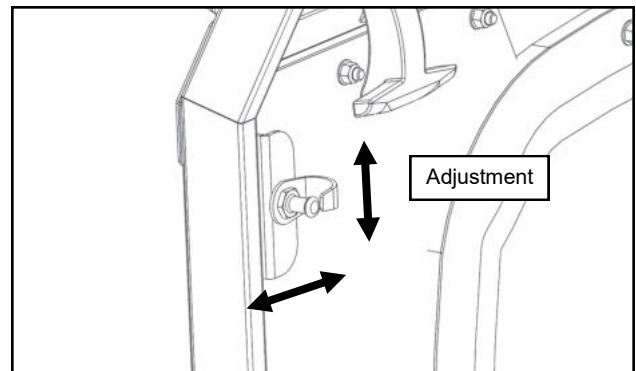

Fig. 18.4 (Striker Pin Adjustment)

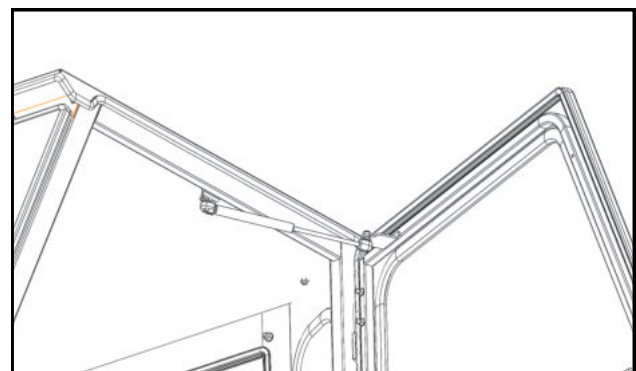

Fig. 18.6 (Gas Struts)

CAB INSTALLATION

STEP 19: (ACCESSORIES/PLUGS)

19.1 If installing accessories, please do so now. If not, use the supplied plastic and/or rubber plugs to fill any exposed holes. See Figure 19.1.

19.2 Optional Rear Wiper Note:

For easier wiper motor harness disconnection, cut the main wiring harness connector off a few inches from the end and create a jumper harness with it using bullet connectors. **Do not cut the connector off the wiper motor.**

Strip all the wires, crimp a male bullet connector onto the ground (black) wire of the main wire harness and a female bullet connector on the positive (red) wire.

Reverse the male and female bullet connectors on the new jumper wire harness so that the male bullet connector is on the positive (red) wire and the female bullet connector is on the ground (black) wire.

NOTE: The rear wiper kit is compatible with the glass rear window only, and can not be installed on a vinyl rear curtain.

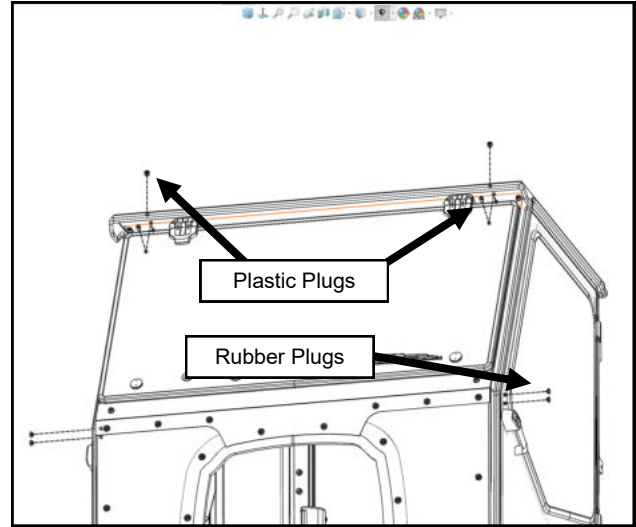

Fig. 19.1 (Install Plugs)

STEP 20: (TURN SIGNAL LIGHTS)

- 20.1 If the turn signal lights were installed on the fenders, install the lights on the signal light brackets at the bottom of the side frames and re-connect.
- 20.2 If the turn signal lights were installed to the ROPS, remove them from the ROPS and install them onto the rear flange of the cab ROPS mounts.
- 20.3 Cover the exposed signal light wires with the supplied 3/8" wire loom.
- 20.4 Re-install the SMV sign to the ROPS, if applicable.

STEP 21: (FINISHING TOUCHES)

21.1 Due to the nature of the packaging materials used for shipping this product, the components of the cab system may have dust on their surfaces upon removal from the packaging. It is recommended that after completion of the cab installation, the cab and vehicle are washed thoroughly to eliminate any dust or contaminants. See the Care and Maintenance section at the back of this manual for critical information on cleaning the cab.

NOTE: this cab may use a common hardware kit and therefore may have extra hardware. Discard additional hardware.

CAB FEATURES & OPERATION

POP-OUT WINDSHIELD

Your CK10 Series cab comes equipped with a pop-out windshield for ventilation. To open the windshield, simply lift up on both of the pop-out latches and rotate until the latches rest in the over-center position.

LIFT-OFF DOORS

For added ventilation, the doors on the CK10 Series cab lift off in seconds without tools.

To lift off:

1) Rotate the doors 45° to the cab and lift. Also, remove the hinge washers and store in a plastic bag.

Store the doors in a safe location to prevent damage.

REMOVABLE REAR WINDOW

The rear window can also be removed for added ventilation.

To remove the rear window:

1. Open both window latches and disconnect from right rear leg with tabs on latch. Open the window taking care not to let the window open into the ROPS or damage may occur.

2. From outside of the cab, lift up on the rear window and slide off the hinges. Remove the hinge washers and store in a plastic bag.

Store the rear window in a safe location to prevent damage.

To reinstall the rear window, reinstall the hinge washers, align the hinges with the pins and drop into place. Re-attach the latches to the rear leg.

VINYL REAR CURTAIN

Rear curtains include straps at the top that allow the curtain to be rolled up and secured.

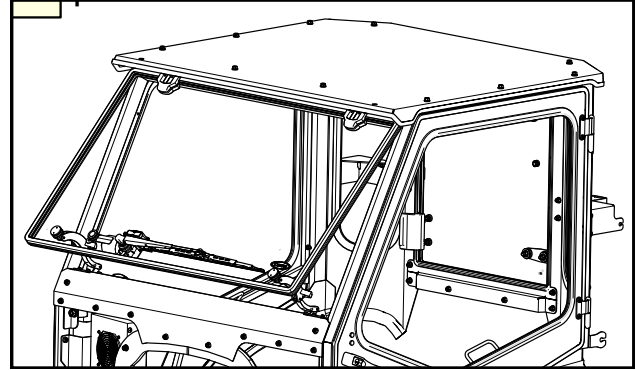

Pop-Out Windshield

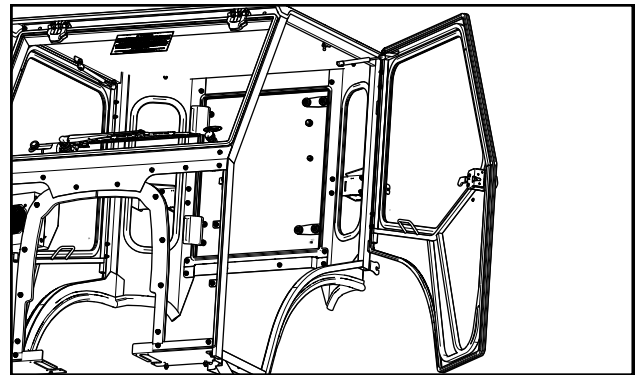

Lift-Off Doors

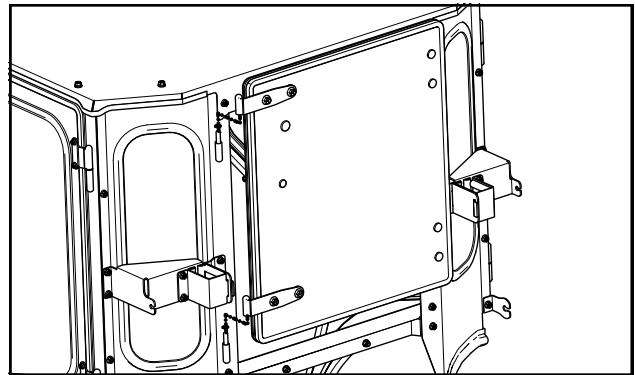

Removable Rear Panel

CARE AND MAINTENANCE

- Re-apply lubrication (preferably grease) periodically as needed to the door striker pins, door latch assemblies, and the door hinges.
- Check and tighten hardware after 40 hours of operation. Periodically inspect and tighten hardware for the remainder of the unit's life.
- Wash the painted surfaces of the cab with commercial automotive cleaning products.
- Clean glass windows with glass cleaner. *Note: Some windows on the cab are acrylic. DO NOT clean acrylic windows with harsh chemicals. It will damage the plastic. Mild soap and water should be used on all acrylic windows.*
- Vinyl components should be washed with a mild solution of warm soapy water.
- Clear vinyl can be easily scratched. Be careful cleaning frost or snow from rear curtain. Do not roll curtains in cold weather. The curtain becomes stiff and may crack. Keep curtain clean.

KIOTI CK10 SERIES CAB SERVICE PARTS

ROOF ASSEMBLY
P/N: 8SV-101-00064

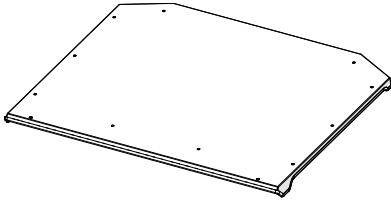

WINDSHIELD ASSEMBLY, 45.75" X 27"
P/N: 8SV-102-00022

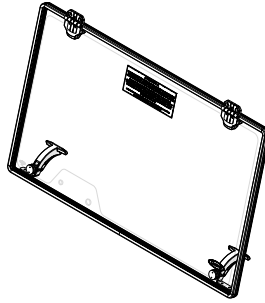

WINDSHIELD SUPPORT
P/N: 8SV-103-00028

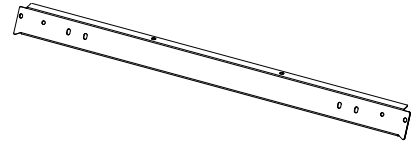

COWL ASSEMBLY
P/N: 8SV-105-00033

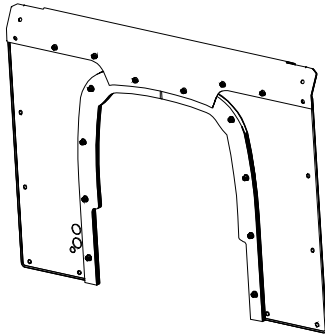

REAR LEG ASSEMBLY, LEFT
P/N: 8SV-108-00026-L

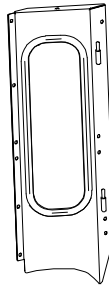

REAR LEG ASSEMBLY, RIGHT
P/N: 8SV-108-00026-R



GLASS REAR PANEL LIFT OFF,
26.75 X 23.25, 3/16" THICK
P/N: 8SV-106-00023

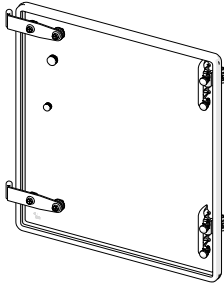

SIDE FRAME ASSEMBLY, LEFT
P/N: 8SV-109-00025-L

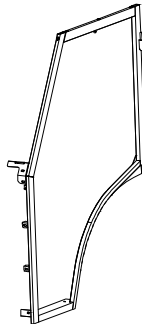

SIDE FRAME ASSEMBLY, RIGHT
P/N: 8SV-109-00025-R

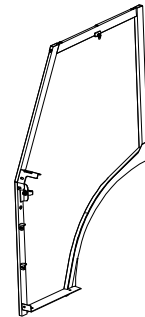

FLOORBOARD MOUNT, LEFT
P/N: 8SV-WA-00544-L

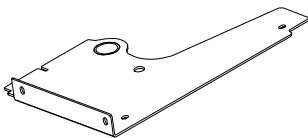

FLOORBOARD MOUNT, RIGHT
P/N: 8SV-WA-00544-R

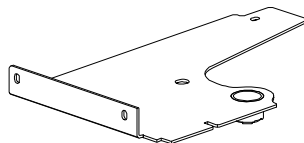

LOWER REAR BRACKET
P/N: 8SV-SM-02182

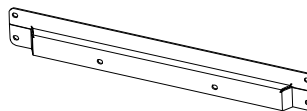

HEATER BRACKET
P/N: 8SV-SM-02199

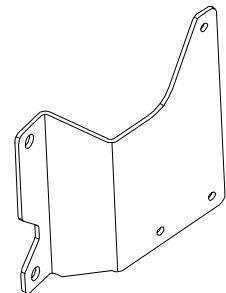

KIOTI CK10 SERIES CAB SERVICE PARTS

ROPS MOUNT, SET (1 LEFT 1 RIGHT)
P/N: 8SV-110-00105

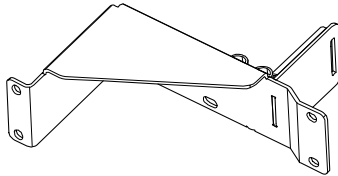
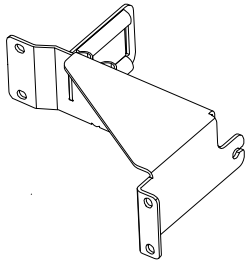

ROPS BRACKET
P/N: 8SV-110-00106 (two)

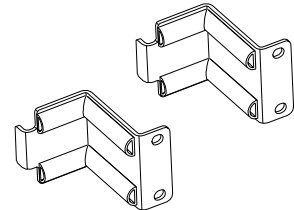

STEP ADAPTER
P/N: 8SV-WA-00524

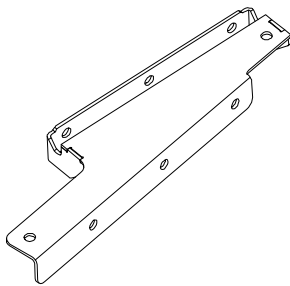

STEEL DOOR
ASSEMBLY, LEFT
P/N: 8SV-107-00053-L

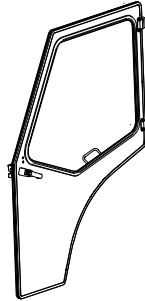

STEEL DOOR
ASSEMBLY, RIGHT
P/N: 8SV-107-00025-R



VINYL DOOR
ASSEMBLY, LEFT
P/N: 8SV-107-00054-L

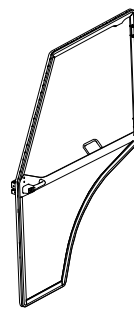

VINYL DOOR
ASSEMBLY, RIGHT
P/N: 8SV-107-00054-R

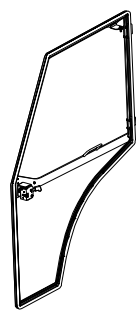

SIGNAL LIGHT BRACKET
P/N: 8SV-SM-02212 (two)

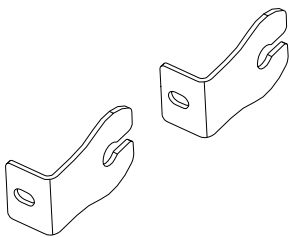

UNDER SEAT FILLER ASSEMBLY
P/N: 8SV-112-00076

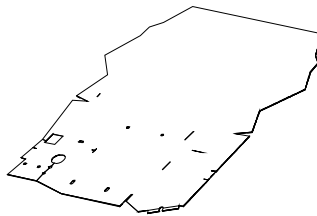

FRONT FILLER ASSEMBLY
P/N: 8SV-112-00077

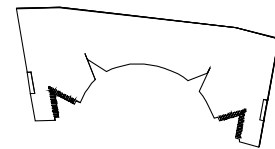

REAR VINYL CURTAN
P/N: 8SV-112-00053

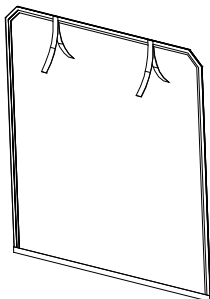

VINYL DOOR SKIN
ASSEMBLY, LEFT
P/N: 8SV-112-00078-L





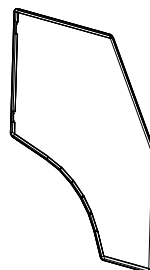

VINYL DOOR SKIN
ASSEMBLY, RIGHT
P/N: 8SV-112-00078-R

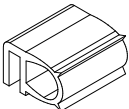

ADDITIONAL SERVICE PARTS

PART NUMBER	DESCRIPTION
8SV-P-00105	REAR LEG WINDOW WITH RUBBER
9SV-DP11	DOMES PLUG 1/2" (BAG OF 10)
9SV-DP10	DOMES PLUG 3/8" (BAG OF 10)
9SV-HWS	WINDSHIELD HINGE KIT
9BLK01	WINDSHIELD HINGE BLOCK SPACER, TALL STYLE, 3/4" THICK
9PWM110	WIPER MOTOR, 110 DEGREE
9PWB20-FB	WIPER BLADE, 20", FLEX
9PWA14-16	WIPER ARM, ADJUSTABLE LENGTH (11" - 16")
9PWK-HB	GLASS MOUNTING KIT FOR WIPER SYSTEMS
9SV-DSTRH	DOOR STRIKER KIT-INCLUDES CASE HARDENED STRIKER BOLT
9SV-IHRL	INSIDE HANDLE ROTARY LATCH KIT (INCL. L & R)
9SV-OHRL	OUTSIDE HANDLE ROTARY LATCH KIT (SET OF 2)
9SV-9PHW010-W	HINGE WASHER, KIT (SET OF 4) OD .635, ID .41, THK .08
9PI01	POLY INSERT 1", 14-20 GA BLK MATTE, INSERT FINS .94/.95 (QTY.: 1)
9PI02	POLY INSERT 3/4", 14-20 GA BLK MATTE FINISH, INSERT FINS 0.69 (QTY.: 1)
9SV-WL1	WINDSHIELD LATCH KIT 1, POPS OPEN W/S FOR VENTING ONLY
8SV-WL3	WINDSHIELD LATCH & BRKT ASS'Y. SGL POST (SET OF L&R)
9SV-GS02Q	GAS SPRINGS, 12-3/8 EXT, QUICK DISCONNECT ENDS (SET OF 2)
9SV-9DPSB	HEATER HOSE BUSHINGS (QTY. 2), SNAP BUSHING, .750" X 1.093"
9SV-9HR-00005	TEE FITTING, 1-1/8" x 1-1/8" x 5/8" (QTY.: ONE)
9SV-9HR0039	90 DEGREE HEATER HOSE ELBOW, 5/8" BARBED ENDS (QTY.: ONE)
9SV-9HR0045	BLOCK ADAPTER (3/8" NIPPLE) (QTY.: 2)
9SV-9HR0048	ROCKER SWITCH (HI-OFF-LOW) (QTY.: ONE)
9SV-9HR00601.0	HOSE CLAMPS #10 (1") (QTY.: 6)
9SV-9HR00601.5	HOSE CLAMPS #16 (1.5") (QTY.: 2)
9SV-HRH61-20	HEATER HOSE (5/8" I.D.)-20 FT
9SV-UHTRILV	UNIVERSAL HEATER IN-LINE VALVE (SET OF 2)
9SV-9HR-L	REPLACEMENT LOUVER-15,000 & 20,000 BTU HEATER
8SV-9PH20WG	TUCK-AWAY HEATER WITH WIRED GROUND
9PH20-2	FAN 120 x 120 x 38 12VDC 12W 3200 RPM
9SV-WH-00072	WIRING HARNESS POWER
8SV-WH-GF	WIRE HARNESS, GLASS FUSE
9DL01H	KEYS, SET OF 2 ON A RING, FOR HANDLE 1096-1, KEY CODE C40
8SV-HKWCG-L	HINGE KIT, TOP & BOT., LEFT
8SV-HKWCG-R	HINGE KIT, TOP & BOT., RIGHT

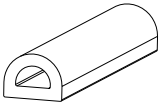
TRIM LOK, STD, 1/16" - 1/8" GRIP	5/8" STD BULB, 1/16" GRIP	WINDOW RUBBER	3/4" SIDE BULB, 1/16" GRIP	1" ROUND BULB, 1/16" GRIP	5/8" SIDE BULB, 1/4" GRIP	ARCH PSA RUBBER .2 X .15
						
9SV-PRO1-20	9SV-PRO2-15	9SV-PR10-20	9SV-PR17-20	9SV-PR19-10	9SV-PR23-15	9SV-PR53-15

OPTIONAL ACCESSORIES FOR ADVANTAGE AND PLUS CABS

FRONT LED WORK LIGHTS (P/N: 9LEDW4)

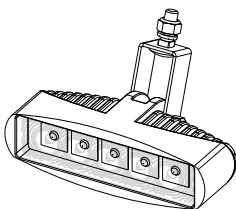

REAR LED WORK LIGHTS (P/N: 9LEDW3)

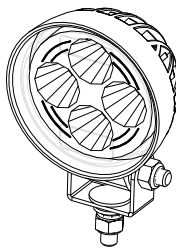

STROBE LIGHT (P/N: 9LEDS2)

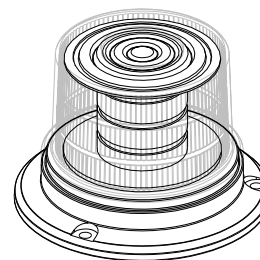

DOME LIGHT (P/N: 9LEDD14)

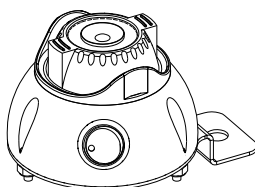

SIDE VIEW MIRRORS (P/N: 9PM5)

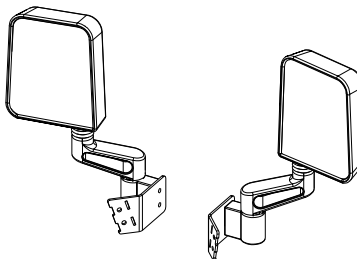

REAR VIEW MIRROR (P/N: 9PM3)

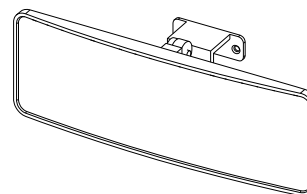

REAR WIPER KIT, 85 DEGREE SWEEP, 12V W/ 16" FLEX BLADE (P/N: 9PWK85F)

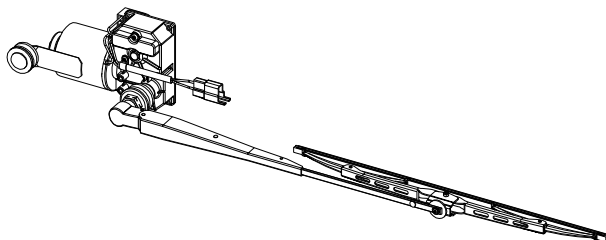

SEAL KIT (P/N: 9SK10)

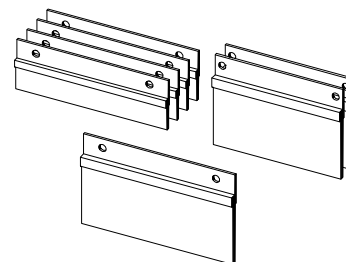



Torque Specs. for Structural Bolts

This page is for use primarily when dealing with high-strength vehicle fasteners such as ROPS hardware that hold the structure together for safety. This page can also be used for other solid metal-to-metal joints. **Do not** use these high torque values on any of the following applications involving: tubing, plastic, nylon or rubber washers, threaded inserts, etc.. See next page regarding less critical fasteners.

The values below apply to fasteners that are dry or lubricated with normal engine oil. They do not apply if special graphited or moly disulphide greases or other extreme pressure lubricants are used. This applies to both UNF and UNC threads.

Remember to always use the same grade or property class when replacing bolts.

IMPORTANT: on all PLATED GRADE 8 bolts, reduce torque 15% from listed bolt torque specification.

SAE Grade No.		2				5				8*			
Bolt head identification mark as per grade. NOTE: Manufacturing Marks Will Vary													
		TORQUE		TORQUE		TORQUE		TORQUE		TORQUE		TORQUE	
Bolt Size		Pounds Feet		Newton-Meters		Pounds Feet		Newton-Meters		Pounds Feet		Newton-Meters	
Inches	Millimeters	Min.	Max.	Min.	Max.	Min.	Max.	Min.	Max.	Min.	Max.	Min.	Max.
1/4	6.35	5	6	7	8	9	11	12	15	12	15	16	20
5/16	7.94	10	12	14	16	17	20.5	23	28	24	29	33	39
3/8	9.53	20	23	27	31	35	42	48	57	45	54	61	73
7/16	11.11	30	35	41	47	54	64	73	87	70	84	95	114
1/2	12.70	45	52	61	70	80	96	109	130	110	132	149	179
9/16	14.29	65	75	88	102	110	132	149	179	160	192	217	260
5/8	15.88	95	105	129	142	150	180	203	244	220	264	298	358
3/4	19.05	150	185	203	251	270	324	366	439	380	456	515	618
7/8	22.23	160	200	217	271	400	480	542	651	600	720	814	976
1	25.40	250	300	339	406	580	696	787	944	900	1080	1220	1464
1-1/8	25.58	-	-	-	-	800	880	1085	1193	1280	1440	1736	1953
1-1/4	31.75	-	-	-	-	1120	1240	1519	1681	1820	2000	2468	2712
1-3/8	34.93	-	-	-	-	1460	1680	1980	2278	2380	2720	3227	3688
1-1/2	38.10	-	-	-	-	1940	2200	2631	2983	3160	3560	4285	4827

*Thick Nuts must be used with Grade 8 bolts

METRIC BOLT TORQUE SPECIFICATIONS



Size of Screw	Property Class	Course Thread			Fine Thread		
		Pitch (mm)	Pounds Feet	Newton-Meters	Pitch (mm)	Pounds Feet	Newton-Meters
M6	5.6	1.0	3.6-5.8	4.9-7.9	-	-	-
	8.8		5.8-9.4	7.9-12.7		-	-
	10.9		7.2-10	9.8-13.6		-	-
M8	5.6	1.25	7.2-14	9.8-19	1.0	12-17	16.3-23
	8.8		17-22	23-29.8		19-27	25.7-36.6
	10.9		20-26	27.1-35.2		22-31	29.8-42
M10	5.6	1.5	20-25	27.1-33.9	1.25	20-29	27.1-39.3
	8.8		34-40	46.1-54.2		35-47	47.4-63.7
	10.9		38-46	51.5-62.3		40-52	54.2-70.5
M12	5.6	1.75	28-34	37.9-46.1	1.25	31-41	42-55.6
	8.8		51-59	69.1-79.9		55-68	75.9-92.1
	10.9		57-66	77.2-89.4		62-75	84-101.6
M14	5.6	2.0	49-56	66.4-75.9	1.5	52-64	70.5-86.7
	8.8		81-93	109.8-126		90-106	122-143.6
	10.9		96-109	130.1-147.7		107-124	145-168
M16	5.6	2.0	67-77	90.8-104.3	1.5	69-83	93.6-112.5
	8.8		116-130	157.2-176.2		120-138	162.6-187
	10.9		129-145	174.8-196.5		140-158	189.7-214.1
M18	5.6	2.0	88-100	119.2-136	1.5	100-117	136-158.5
	8.8		150-168	203.3-227.6		177-199	239.8-269.6
	10.9		175-194	237.1-262.9		202-231	273.7-313
M20	5.6	2.5	108-130	146.3-176.2	1.5	132-150	178.9-203.3
	8.8		186-205	252-277.8		206-242	279.1-327.9
	10.9		213-249	288.6-337.4		246-289	333.3-391.6

Tightening of Non-Structural Bolts

For light or medium duty fastening, Curtis recommends using a general industry standard of tightening until snug and then giving an additional one quarter turn of the tool as deemed reasonable for the application (i.e.: at the installer's discretion).

If torque values are required, the examples listed below are intended as a reasonable reference for use in the majority of non-structural fastener applications such as: small diameter fasteners; bolts passing thru tubing, glass, plastic, nylon or rubber washers, threaded inserts, etc.

If more than one application below applies, use the lower torque value.

FASTENER SIZE:	FASTENER TYPE:	WASHER MATERIAL:	APPLICATION:	TORQUE (INCH-POUNDS) (±5)
#10	Machine Screws	-	in Nylon P-Clamps	20
#10	Machine Screws	-	Strobe Light (plastic base)	35
M5	Set Screws	-	Wiper Arm	20
1/4"	Cap Nut	-	Windshield Wiper	20
1/4"	Bolts	-	Tubing (5/8" to 3/4" wide)	132
1/4"	Bolts	Rubber	-	60
1/4"	Bolts	Nylon / Plastic	-	72
1/4"	Bolts	-	Factory Installed Threaded Inserts	132
5/16"	Bolts	-	Tubing (1" or wider)	60
5/16"	Flat Head Bolts	-	Plastic Windshield Hinge	79
5/16"	Bolts	Rubber	-	120
5/16"	Bolts	Nylon / Plastic	-	150
5/16"	Ball Studs	-	-	150
5/16"	Bolts	-	Factory Installed Threaded Inserts	240
3/8"	Bolts	-	Tubing	120
M12	Door Striker Pins	-	-	120